

OUTDOOR UNIT

Revision P:

- 1. TECHNICAL CHANGES, 4. SPECIFICATION and 9. DATA have been corrected.

OBH702 REVISED EDITION-N is void.

SERVICE MANUAL



No. OBH702
REVISED EDITION-P

Models

MXZ-2C20NA2 - U1, U4
 MXZ-2C20NA3 - U1
 MXZ-2C20NA4 - U1
 MXZ-3C24NA
 MXZ-3C24NA2 - U1
 MXZ-3C24NA3 - U1
 MXZ-3C24NA4 - U1
 MXZ-3C30NA
 MXZ-3C30NA2 - U1
 MXZ-3C30NA3 - U1
 MXZ-3C30NA4 - U1
 MXZ-4C36NA
 MXZ-4C36NA2 - U1
 MXZ-4C36NA3 - U1
 MXZ-4C36NA4 - U1
 MXZ-5C42NA
 MXZ-5C42NA2 - U1
 MXZ-5C42NA3 - U1
 MXZ-5C42NA4 - U1

MXZ-2C20NAHZ
 MXZ-2C20NAHZ2 - U1
 MXZ-2C20NAHZ3 - U1
 MXZ-2C20NAHZ4 - U1
 MXZ-3C24NAHZ
 MXZ-3C24NAHZ2 - U1
 MXZ-3C24NAHZ3 - U1
 MXZ-3C24NAHZ4 - U1
 MXZ-3C30NAHZ
 MXZ-3C30NAHZ2 - U1
 MXZ-3C30NAHZ3 - U1
 MXZ-3C30NAHZ4 - U1

Indoor unit service manual

MSZ-FE·NA Series (OBH542)
 MSZ-FH·NA Series (OBH683)
 MSZ-GE·NA Series (OBH548)
 MSZ-GL·NA Series (OBH732)
 MSZ-EF·NA Series (OBH736)
 MSZ-FS·NA Series (OBH872)
 MFZ-KA·NA Series (OBH568)
 MFZ-KJ·NA Series (OBH752)
 SLZ-KA·NA Series (OCH487)
 SLZ-KF·NA.TH Series (OCH669)
 PLA-A·BA Series (OCH420)
 PLA-A·EA Series (OCH640)
 SEZ-KD·NA Series
 PEAD-A·AA Series
 PCA-A·KA Series (OCH455)
 MVZ-A·AA Series
 SVZ-KP·NA Series (MD-1404-K019)

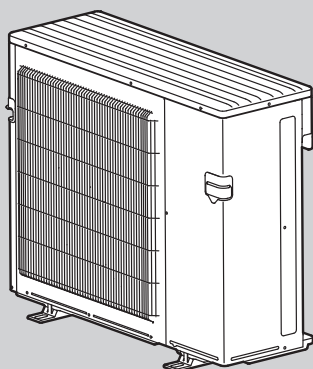

MXZ-3C24NA MXZ-3C30NA MXZ-4C36NA
 MXZ-3C24NA2 MXZ-3C30NA2 MXZ-4C36NA2
 MXZ-3C24NA3 MXZ-3C30NA3 MXZ-4C36NA3
 MXZ-3C24NA4 MXZ-3C30NA4 MXZ-4C36NA4

CONTENTS

- INDOOR / OUTDOOR UNIT COMPATIBILITY TABLE 4
- 1. TECHNICAL CHANGES 8
- 2. SAFETY PRECAUTION 9
- 3. PART NAMES AND FUNCTIONS 13
- 4. SPECIFICATION 14
- 5. NOISE CRITERIA CURVES 30
- 6. OUTLINES AND DIMENSIONS 33
- 7. WIRING DIAGRAM 39
- 8. REFRIGERANT SYSTEM DIAGRAM 62
- 9. DATA 75
- 10. ACTUATOR CONTROL 106
- 11. SERVICE FUNCTIONS 107
- 12. TROUBLESHOOTING 110
- 13. DISASSEMBLY INSTRUCTIONS 141

PARTS CATALOG (OBB702)

Use the specified refrigerant only

Never use any refrigerant other than that specified.

Doing so may cause a burst, an explosion, or fire when the unit is being used, serviced, or disposed of.

Correct refrigerant is specified in the manuals and on the spec labels provided with our products.

We will not be held responsible for mechanical failure, system malfunction, unit breakdown or accidents caused by failure to follow the instructions.

<Preparation before the repair service>

- Prepare the proper tools.
- Prepare the proper protectors.
- Provide adequate ventilation.
- After stopping the operation of the air conditioner, turn off the power-supply breaker and pull the power plug.
- Discharge the capacitor before the work involving the electric parts.

<Precautions during the repair service>

- Do not perform the work involving the electric parts with wet hands.
- Do not pour water into the electric parts.
- Do not touch the refrigerant.
- Do not touch the hot or cold areas in the refrigeration cycle.
- When the repair or the inspection of the circuit needs to be done without turning off the power, exercise great caution not to touch the live parts.

WARNING

- **When the refrigeration circuit has a leak, do not execute pump down with the compressor.**
- **When pumping down the refrigerant, stop the compressor before disconnecting the refrigerant pipes. The compressor may burst if air etc. get into it.**
- **When opening or closing the valve below freezing temperatures, refrigerant may spurt out from the gap between the valve stem and the valve body, resulting in injuries.**

Revision A:

- MXZ-3C24NA, MXZ-3C30NA and MXZ-4C36NA have been added.

Revision B:

- MXZ-3C24/3C30/4C36/5C42NA2 and MXZ-2C20/3C24/3C30NAHZ2 - [U1] have been added.

Revision C:

- 4. SPECIFICATION has been changed.
- Some descriptions have been modified.

Revision D:

- Connectable indoor unit lineups have been modified.
- WIRING DIAGRAM (7.) and TEST POINT DIAGRAM AND VOLTAGE (12-7.) have been changed.

Revision E:

- Capacity and input curve have been corrected.

Revision F:

- MXZ-2C20NA2 - [U1] has been added.

Revision G:

- 5. NOISE CRITERIA CURVES has been changed.

Revision H:

- MSZ-FS-NA series have been added to INDOOR / OUTDOOR UNIT COMPATIBILITY TABLE.
- 2. SAFETY PRECAUTION has been added.
- 9-2. CAPACITY AND THE INPUT CURVES has been modified.
- 12. TROUBLESHOOTING has been modified.

Revision J:

- MXZ-2C20NA2 - [U4] has been added.

Revision K:

- MXZ-2C20/3C24/3C30/4C36/5C42NA3 - [U1] and MXZ-2C20/3C24/3C30NAHZ3 - [U1] have been added.

Revision L:

- Models of refrigeration oil for MXZ-3C24/3C30/4C36/5C42NA3 - [U1] and MXZ-2C20/3C24/3C30NAHZ3 - [U1] at 4. SPECIFICATION have been added.

Revision M:

- MXZ-2C20/3C24/3C30/4C36/5C42NA4 - [U1] and MXZ-2C20/3C24/3C30NAHZ4 - [U1] have been added.

Revision N:

- 4. SPECIFICATION and 8. REFRIGERANT SYSTEM DIAGRAM have been corrected.
Specifications of MXZ-2C20NA4/MXZ-3C24NA4/MXZ-3C30NA4 - [U1] have been corrected.
Refrigerant system diagrams of MXZ-3C24/3C30/4C36NA and MXZ-3C24/3C30/4C36NA2/NA3 - [U1] have been corrected.

Revision P:

- 1. TECHNICAL CHANGES has been corrected.
Descriptions of technical changes for MXZ-2C20/3C24/3C30/4C36/5C42NA4 - [U1] and MXZ-2C20/3C24/3C30NAHZ4 - [U1] have been corrected.
- 4. SPECIFICATION has been corrected.
"Min. circuit ampacity" of MXZ-4C36NA and MXZ-4C36NA2/NA3/NA4-U1 have been corrected.
- 9. DATA has been corrected.
"Ref. pipe length" have been corrected.
"Fan speed" and "Airflow" of MXZ-3C30NAHZ and MXZ-3C30NAHZ2/NAHZ3/NAHZ4 - [U1] have been corrected.

INDOOR / OUTDOOR UNIT COMPATIBILITY TABLE

<MXZ-2C20NA2-U1/U4>

Connectable indoor unit lineups (Heat pump inverter type)		Capacity class [kBTU/h]							
Model type	Model name	06	09	12	15	18	24	30	36
Wall mounted	MSZ-FE**NA		●	●					
	MSZ-FH**NA	●	●	●	●				
	MSZ-FH**NA2								
	MSZ-FS**NA	●	●	●	●				
	MSZ-GE**NA	●	●	●	●				
	MSZ-GL**NA-U1	●	●	●	●				
Floor standing	MSZ-EF**NA-U1		●	●	●				
	MFZ-KA**NA		●	●					
4-way cassette	MFZ-KJ**NA-U1		●	●	●				
	SLZ-KA**NA.TH		●	●					
	SLZ-KF**NA.TH		●	●					
Ceiling concealed	PLA-A**BA6								
	PLA-A**EA7								
	SEZ-KD**NA4.TH		●	●	●				
Ceiling suspended	PEAD-A**AA5		●	●					
	PCA-A**KA6.TH								
Multi-position	MVZ-A**AA4			●					
	SVZ-KP**NA			●					

<MXZ-2C20NAHZ2-U1>

Connectable indoor unit lineups (Heat pump inverter type)		Capacity class [kBTU/h]							
Model type	Model name	06	09	12	15	18	24	30	36
Wall mounted	MSZ-FE**NA		●	●					
	MSZ-FH**NA	●	●	●	●				
	MSZ-FH**NA2								
	MSZ-FS**NA	●	●	●	●				
	MSZ-GE**NA	●	●	●	●				
	MSZ-GL**NA-U1	●	●	●	●				
Floor standing	MSZ-EF**NA-U1		●	●	●				
	MFZ-KA**NA		●	●					
4-way cassette	MFZ-KJ**NA-U1		●	●	●				
	SLZ-KA**NA.TH		●	●					
	SLZ-KF**NA.TH		●	●					
Ceiling concealed	PLA-A**BA6								
	PLA-A**EA7								
	SEZ-KD**NA4.TH		●	●	●				
Ceiling suspended	PEAD-A**AA5		●	●					
	PCA-A**KA6.TH								
Multi-position	MVZ-A**AA4			●					
	SVZ-KP**NA			●					

<MXZ-2C20NA3-U1, MXZ-2C20NA4-U1>

Connectable indoor unit lineups (Heat pump inverter type)		Capacity class [kBTU/h]							
Model type	Model name	06	09	12	15	18	24	30	36
Wall mounted	MSZ-FE**NA		●	●					
	MSZ-FH**NA	●	●	●	●				
	MSZ-FH**NA2								
	MSZ-FS**NA	●	●	●	●				
	MSZ-GE**NA	●	●	●	●				
	MSZ-GL**NA-U1	●	●	●	●				
Floor standing	MSZ-GS**NA-U1	●	●	●	●				
	MSZ-EF**NA-U1		●	●	●				
4-way cassette	MFZ-KA**NA		●	●					
	MFZ-KJ**NA-U1		●	●	●				
	SLZ-KA**NA.TH		●	●					
1-way cassette	SLZ-KF**NA.TH		●	●					
	PLA-A**BA6								
	PLA-A**EA7								
Ceiling concealed	MLZ-KP**NA-U1		●	●					
	MLZ-KP**NA2-U1		●	●					
	MLZ-KY**NA-U1	●							
Ceiling suspended	SEZ-KD**NA4.TH		●	●	●				
	PEAD-A**AA7		●	●					
Multi-position	PCA-A**KA7.TH								
	MVZ-A**AA4			●					
	SVZ-KP**NA			●					

<MXZ-2C20NAHZ3-U1, MXZ-2C20NAHZ4-U1>

Connectable indoor unit lineups (Heat pump inverter type)		Capacity class [kBTU/h]							
Model type	Model name	06	09	12	15	18	24	30	36
Wall mounted	MSZ-FE**NA		●	●					
	MSZ-FH**NA	●	●	●	●				
	MSZ-FH**NA2								
	MSZ-FS**NA	●	●	●	●				
	MSZ-GE**NA	●	●	●	●				
	MSZ-GL**NA-U1	●	●	●	●				
Floor standing	MSZ-GS**NA-U1	●	●	●	●				
	MSZ-EF**NA-U1		●	●	●				
4-way cassette	MFZ-KA**NA		●	●					
	MFZ-KJ**NA-U1		●	●	●				
	SLZ-KA**NA.TH		●	●					
1-way cassette	SLZ-KF**NA.TH		●	●					
	PLA-A**BA6								
	PLA-A**EA7								
Ceiling concealed	MLZ-KP**NA-U1		●	●					
	MLZ-KP**NA2-U1		●	●					
	MLZ-KY**NA-U1	●							
Ceiling suspended	SEZ-KD**NA4.TH		●	●	●				
	PEAD-A**AA7		●	●					
Multi-position	PCA-A**KA7.TH								
	MVZ-A**AA4			●					
	SVZ-KP**NA			●					

<MXZ-2C20NAHZ>

Connectable indoor unit lineups (Heat pump inverter type)		Capacity class [kBTU/h]							
Model type	Model name	06	09	12	15	18	24	30	36
Wall mounted	MSZ-FE**NA		●	●					
	MSZ-FH**NA		●	●	●				
	MSZ-FH**NA2								
	MSZ-FS**NA								
	MSZ-GE**NA	●	●	●	●				
	MSZ-GL**NA-U1	●	●	●	●				
Floor standing	MSZ-EF**NA-U1		●	●					
	MFZ-KA**NA		●	●					
4-way cassette	MFZ-KJ**NA-U1		●	●					
	SLZ-KA**NA.TH		●	●					
	SLZ-KF**NA.TH		●	●					
Ceiling concealed	PLA-A**BA6								
	PLA-A**EA7								
	SEZ-KD**NA4.TH		●	●	●				
Ceiling suspended	PEAD-A**AA5		●	●					
	PCA-A**KA6.TH								
Multi-position	MVZ-A**AA4			●					
	SVZ-KP**NA			●					

<MXZ-3C24NA>

Connectable indoor unit lineups (Heat pump inverter type)		Capacity class [kBTU/h]							
Model type	Model name	06	09	12	15	18	24	30	36
Wall mounted	MSZ-FE**NA		●	●					
	MSZ-FH**NA		●	●	●	●			
	MSZ-FH**NA2								
	MSZ-FS**NA								
	MSZ-GE**NA	●	●	●	●	●			
	MSZ-GL**NA-U1	●	●	●	●	●			
Floor standing	MSZ-EF**NA-U1		●	●					
	MFZ-KA**NA		●	●					
4-way cassette	MFZ-KJ**NA-U1		●	●	●				
	SLZ-KA**NA.TH		●	●	●				
	SLZ-KF**NA.TH		●	●					
Ceiling concealed	PLA-A**BA6								
	PLA-A**EA7								
	SEZ-KD**NA4.TH		●	●	●	●			
Ceiling suspended	PEAD-A**AA5		●	●					
	PCA-A**KA6.TH								
Multi-position	MVZ-A**AA4			●					
	SVZ-KP**NA			●					

<MXZ-3C24NA2-U1>

Connectable indoor unit lineups (Heat pump inverter type)		Capacity class [kBTU/h]							
Model type	Model name	06	09	12	15	18	24	30	36
Wall mounted	MSZ-FE**NA		●	●					
	MSZ-FH**NA	●	●	●	●	●			
	MSZ-FH**NA2								
	MSZ-FS**NA	●	●	●	●	●			
	MSZ-GE**NA	●	●	●	●	●			
	MSZ-GL**NA-U1	●	●	●	●	●			
Floor standing	MFZ-KA**NA		●	●					
	MFZ-KJ**NA-U1		●	●	●	●			
4-way cassette	SLZ-KA**NA.TH		●	●	●				
	SLZ-KF**NA.TH		●	●	●				
	PLA-A**BA6						●		
	PLA-A**EA7						●		
Ceiling concealed	SEZ-KD**NA4.TH		●	●	●	●			
	PEAD-A**AA5		●	●	●	●			
Ceiling suspended	PCA-A**KA6.TH								
Multi-position	MVZ-A**AA4			●		●			
	SVZ-KP**NA			●		●			

<MXZ-3C24NA3-U1, MXZ-3C24NA4-U1>

Connectable indoor unit lineups (Heat pump inverter type)		Capacity class [kBTU/h]							
Model type	Model name	06	09	12	15	18	24	30	36
Wall mounted	MSZ-FE**NA		●	●					
	MSZ-FH**NA	●	●	●	●	●			
	MSZ-FH**NA2								
	MSZ-FS**NA	●	●	●	●	●			
	MSZ-GE**NA	●	●	●	●	●			
	MSZ-GL**NA-U1	●	●	●	●	●			
Floor standing	MFZ-KA**NA		●	●					
	MFZ-KJ**NA-U1		●	●	●	●			
4-way cassette	SLZ-KA**NA.TH		●	●	●				
	SLZ-KF**NA.TH		●	●	●				
	PLA-A**BA6						●		
1-way cassette	MLZ-KP**NA-U1		●	●		●			
	MLZ-KP**NA2-U1		●	●		●			
	MLZ-KY**NA-U1	●							
Ceiling concealed	SEZ-KD**NA4.TH		●	●	●	●			
	PEAD-A**AA7		●	●	●	●			
Ceiling suspended	PCA-A**KA7.TH								
Multi-position	MVZ-A**AA4			●		●			
	SVZ-KP**NA			●		●			
	PAA-A**								

<MXZ-3C24NAHZ>

Connectable indoor unit lineups (Heat pump inverter type)		Capacity class [kBTU/h]							
Model type	Model name	06	09	12	15	18	24	30	36
Wall mounted	MSZ-FE**NA		●	●					
	MSZ-FH**NA	●	●	●	●	●			
	MSZ-FH**NA2								
	MSZ-FS**NA	●	●	●	●	●			
	MSZ-GE**NA	●	●	●	●	●			
	MSZ-GL**NA-U1	●	●	●	●	●			
Floor standing	MFZ-KA**NA		●	●					
	MFZ-KJ**NA-U1		●	●	●	●			
4-way cassette	SLZ-KA**NA.TH		●	●	●				
	SLZ-KF**NA.TH		●	●	●				
	PLA-A**BA6						●		
	PLA-A**EA7						●		
Ceiling concealed	SEZ-KD**NA4.TH		●	●	●	●			
	PEAD-A**AA5		●	●	●	●			
Ceiling suspended	PCA-A**KA6.TH								
Multi-position	MVZ-A**AA4			●		●			
	SVZ-KP**NA			●		●			

<MXZ-3C24NAHZ2-U1>

Connectable indoor unit lineups (Heat pump inverter type)		Capacity class [kBTU/h]							
Model type	Model name	06	09	12	15	18	24	30	36
Wall mounted	MSZ-FE**NA		●	●					
	MSZ-FH**NA	●	●	●	●	●			
	MSZ-FH**NA2								
	MSZ-FS**NA	●	●	●	●	●			
	MSZ-GE**NA	●	●	●	●	●			
	MSZ-GL**NA-U1	●	●	●	●	●			
Floor standing	MFZ-KA**NA		●	●					
	MFZ-KJ**NA-U1		●	●	●	●			
4-way cassette	SLZ-KA**NA.TH		●	●	●				
	SLZ-KF**NA.TH		●	●	●				
	PLA-A**BA6						●		
	PLA-A**EA7						●		
Ceiling concealed	SEZ-KD**NA4.TH		●	●	●	●			
	PEAD-A**AA5		●	●	●	●			
Ceiling suspended	PCA-A**KA6.TH								
Multi-position	MVZ-A**AA4			●		●			
	SVZ-KP**NA			●		●			

<MXZ-3C24NAHZ3-U1, MXZ-3C24NAHZ4-U1>

Connectable indoor unit lineups (Heat pump inverter type)		Capacity class [kBTU/h]							
Model type	Model name	06	09	12	15	18	24	30	36
Wall mounted	MSZ-FE**NA		●	●					
	MSZ-FH**NA	●	●	●	●	●			
	MSZ-FH**NA2								
	MSZ-FS**NA	●	●	●	●	●			
	MSZ-GE**NA	●	●	●	●	●			
	MSZ-GL**NA-U1	●	●	●	●	●			
Floor standing	MFZ-KA**NA		●	●					
	MFZ-KJ**NA-U1		●	●	●	●			
4-way cassette	SLZ-KA**NA.TH		●	●	●				
	SLZ-KF**NA.TH		●	●	●				
	PLA-A**BA6						●		
1-way cassette	MLZ-KP**NA-U1		●	●		●			
	MLZ-KP**NA2-U1		●	●		●			
	MLZ-KY**NA-U1	●							
Ceiling concealed	SEZ-KD**NA4.TH		●	●	●	●			
	PEAD-A**AA7		●	●	●	●			
Ceiling suspended	PCA-A**KA7.TH								
Multi-position	MVZ-A**AA4			●		●			
	SVZ-KP**NA			●		●			
	PAA-A**								

<MXZ-3C30NA>

Connectable indoor unit lineups (Heat pump inverter type)		Capacity class [kBTU/h]							
Model type	Model name	06	09	12	15	18	24	30	36
Wall mounted	MSZ-FE**NA		●	●					
	MSZ-FH**NA	●	●	●	●	●			
	MSZ-FH**NA2								
	MSZ-FS**NA	●	●	●	●	●			
	MSZ-GE**NA	●	●	●	●	●			
	MSZ-GL**NA-U1	●	●	●	●	●			
Floor standing	MFZ-KA**NA		●	●					
	MFZ-KJ**NA-U1		●	●	●	●			
4-way cassette	SLZ-KA**NA.TH		●	●	●				
	SLZ-KF**NA.TH		●	●	●				
	PLA-A**BA6						●		
	PLA-A**EA7						●		
Ceiling concealed	SEZ-KD**NA4.TH		●	●	●	●			
	PEAD-A**AA5		●	●	●	●			
Ceiling suspended	PCA-A**KA6.TH								
Multi-position	MVZ-A**AA4			●		●			
	SVZ-KP**NA			●		●			

<MXZ-3C30NA2-U1>

Connectable indoor unit lineups (Heat pump inverter type)		Capacity class [kBTU/h]							
Model type	Model name	06	09	12	15	18	24	30	36
Wall mounted	MSZ-FE**NA		●	●					
	MSZ-FH**NA	●	●	●	●	●			
	MSZ-FH**NA2								
	MSZ-FS**NA	●	●	●	●	●			
	MSZ-GE**NA	●	●	●	●	●			
	MSZ-GL**NA-U1	●	●	●	●	●	●		
	MSZ-EF**NA-U1		●	●	●	●			
Floor standing	MFZ-KA**NA		●	●		●			
	MFZ-KJ**NA-U1		●	●	●	●			
4-way cassette	SLZ-KA**NA.TH		●	●	●				
	SLZ-KF**NA.TH		●	●	●				
	PLA-A**BA6					●	●		
	PLA-A**EA7					●			
Ceiling concealed	SEZ-KD**NA4.TH		●	●	●	●			
	PEAD-A**AA5		●	●	●	●			
Ceiling suspended	PCA-A**KA6.TH						●		
Multi-position	MVZ-A**AA4			●		●	●		
	SVZ-KP**NA			●		●	●		

<MXZ-3C30NAHZ2-U1>

Connectable indoor unit lineups (Heat pump inverter type)		Capacity class [kBTU/h]							
Model type	Model name	06	09	12	15	18	24	30	36
Wall mounted	MSZ-FE**NA		●	●					
	MSZ-FH**NA	●	●	●	●	●			
	MSZ-FH**NA2								
	MSZ-FS**NA	●	●	●	●	●			
	MSZ-GE**NA	●	●	●	●	●			
	MSZ-GL**NA-U1	●	●	●	●	●	●		
	MSZ-EF**NA-U1		●	●	●	●			
Floor standing	MFZ-KA**NA		●	●		●			
	MFZ-KJ**NA-U1		●	●	●	●			
4-way cassette	SLZ-KA**NA.TH		●	●	●				
	SLZ-KF**NA.TH		●	●	●				
	PLA-A**BA6					●	●		
	PLA-A**EA7					●			
Ceiling concealed	SEZ-KD**NA4.TH		●	●	●	●			
	PEAD-A**AA5		●	●	●	●			
Ceiling suspended	PCA-A**KA6.TH						●		
Multi-position	MVZ-A**AA4			●		●	●		
	SVZ-KP**NA			●		●	●		

<MXZ-3C30NA3-U1, MXZ-3C30NA4-U1>

Connectable indoor unit lineups (Heat pump inverter type)		Capacity class [kBTU/h]							
Model type	Model name	06	09	12	15	18	24	30	36
Wall mounted	MSZ-FE**NA		●	●					
	MSZ-FH**NA	●	●	●	●	●			
	MSZ-FH**NA2								
	MSZ-FS**NA	●	●	●	●	●			
	MSZ-GE**NA	●	●	●	●	●			
	MSZ-GL**NA-U1	●	●	●	●	●	●		
	MSZ-GS**NA-U1	●	●	●	●	●	●		
Floor standing	MFZ-KA**NA		●	●		●			
	MFZ-KJ**NA-U1		●	●	●	●			
4-way cassette	SLZ-KA**NA.TH		●	●	●				
	SLZ-KF**NA.TH		●	●	●				
	PLA-A**BA6					●	●		
	PLA-A**EA7					●			
1-way cassette	MLZ-KP**NA-U1		●	●		●			
	MLZ-KP**NA2-U1		●	●		●			
	MLZ-KY**NA-U1	●							
Ceiling concealed	SEZ-KD**NA4.TH		●	●	●	●			
	PEAD-A**AA7		●	●	●	●			
Ceiling suspended	PCA-A**KA7.TH						●		
Multi-position	MVZ-A**AA4			●		●	●		
	SVZ-KP**NA			●		●	●		
	PAA-A**					●	●		

<MXZ-3C30NAHZ3-U1, MXZ-3C30NAHZ4-U1>

Connectable indoor unit lineups (Heat pump inverter type)		Capacity class [kBTU/h]							
Model type	Model name	06	09	12	15	18	24	30	36
Wall mounted	MSZ-FE**NA		●	●					
	MSZ-FH**NA	●	●	●	●	●			
	MSZ-FH**NA2								
	MSZ-FS**NA	●	●	●	●	●			
	MSZ-GE**NA	●	●	●	●	●			
	MSZ-GL**NA-U1	●	●	●	●	●	●		
	MSZ-GS**NA-U1	●	●	●	●	●	●		
Floor standing	MFZ-KA**NA		●	●		●			
	MFZ-KJ**NA-U1		●	●	●	●			
4-way cassette	SLZ-KA**NA.TH		●	●	●				
	SLZ-KF**NA.TH		●	●	●				
	PLA-A**BA6					●	●		
	PLA-A**EA7					●			
1-way cassette	MLZ-KP**NA-U1		●	●		●			
	MLZ-KP**NA2-U1		●	●		●			
	MLZ-KY**NA-U1	●							
Ceiling concealed	SEZ-KD**NA4.TH		●	●	●	●			
	PEAD-A**AA7		●	●	●	●			
Ceiling suspended	PCA-A**KA7.TH						●		
Multi-position	MVZ-A**AA4			●		●	●		
	SVZ-KP**NA			●		●	●		
	PAA-A**					●	●		

<MXZ-3C30NAHZ>

Connectable indoor unit lineups (Heat pump inverter type)		Capacity class [kBTU/h]							
Model type	Model name	06	09	12	15	18	24	30	36
Wall mounted	MSZ-FE**NA		●	●					
	MSZ-FH**NA		●	●	●	●			
	MSZ-FH**NA2								
	MSZ-FS**NA								
	MSZ-GE**NA	●	●	●	●	●			
	MSZ-GL**NA-U1	●	●	●	●	●	●		
	MSZ-EF**NA-U1		●	●	●	●			
Floor standing	MFZ-KA**NA		●	●		●			
	MFZ-KJ**NA-U1		●	●	●	●			
4-way cassette	SLZ-KA**NA.TH		●	●	●				
	SLZ-KF**NA.TH		●	●	●				
	PLA-A**BA6					●	●		
	PLA-A**EA7					●			
Ceiling concealed	SEZ-KD**NA4.TH		●	●	●	●			
	PEAD-A**AA5		●	●	●	●			
Ceiling suspended	PCA-A**KA6.TH						●		
Multi-position	MVZ-A**AA4			●		●	●		
	SVZ-KP**NA			●		●	●		

<MXZ-4C36NA>

Connectable indoor unit lineups (Heat pump inverter type)		Capacity class [kBTU/h]							
Model type	Model name	06	09	12	15	18	24	30	36
Wall mounted	MSZ-FE**NA		●	●					
	MSZ-FH**NA		●	●	●	●			
	MSZ-FH**NA2								
	MSZ-FS**NA								
	MSZ-GE**NA	●	●	●	●	●			
	MSZ-GL**NA-U1	●	●	●	●	●	●		
	MSZ-EF**NA-U1		●	●	●	●			
Floor standing	MFZ-KA**NA		●	●		●			
	MFZ-KJ**NA-U1		●	●	●	●			
4-way cassette	SLZ-KA**NA.TH		●	●	●				
	SLZ-KF**NA.TH		●	●	●				
	PLA-A**BA6					●	●		
	PLA-A**EA7					●			
Ceiling concealed	SEZ-KD**NA4.TH		●	●	●	●			
	PEAD-A**AA5		●	●	●	●			
Ceiling suspended	PCA-A**KA6.TH						●		
Multi-position	MVZ-A**AA4			●		●	●		
	SVZ-KP**NA			●		●	●		

<MXZ-4C36NA2-U1>

Connectable indoor unit lineups (Heat pump inverter type)		Capacity class [kBTU/h]							
Model type	Model name	06	09	12	15	18	24	30	36
Wall mounted	MSZ-FE**NA		●	●					
	MSZ-FH**NA	●	●	●	●	●			
	MSZ-FH**NA2								
	MSZ-FS**NA	●	●	●	●	●			
	MSZ-GE**NA	●	●	●	●	●	●		
	MSZ-GL**NA-U1	●	●	●	●	●	●		
	MSZ-EF**NA-U1		●	●	●	●			
Floor standing	MFZ-KA**NA		●	●		●			
	MFZ-KJ**NA-U1		●	●	●	●			
4-way cassette	SLZ-KA**NA.TH		●	●	●				
	SLZ-KF**NA.TH		●	●	●				
	PLA-A**BA6					●	●		
	PLA-A**EA7					●			
Ceiling concealed	SEZ-KD**NA4.TH		●	●	●	●			
	PEAD-A**AA5		●	●	●	●	●		
Ceiling suspended	PCA-A**KA6.TH						●		
Multi-position	MVZ-A**AA4			●		●	●		
	SVZ-KP**NA			●		●	●		

<MXZ-5C42NA2-U1>

Connectable indoor unit lineups (Heat pump inverter type)		Capacity class [kBTU/h]							
Model type	Model name	06	09	12	15	18	24	30	36
Wall mounted	MSZ-FE**NA		●	●					
	MSZ-FH**NA	●	●	●	●	●			
	MSZ-FH**NA2								
	MSZ-FS**NA	●	●	●	●	●			
	MSZ-GE**NA	●	●	●	●	●	●		
	MSZ-GL**NA-U1	●	●	●	●	●	●		
	MSZ-EF**NA-U1		●	●	●	●			
Floor standing	MFZ-KA**NA		●	●		●			
	MFZ-KJ**NA-U1		●	●	●	●			
4-way cassette	SLZ-KA**NA.TH		●	●	●				
	SLZ-KF**NA.TH		●	●	●				
	PLA-A**BA6					●	●		
	PLA-A**EA7					●			
Ceiling concealed	SEZ-KD**NA4.TH		●	●	●	●			
	PEAD-A**AA5		●	●	●	●	●		
Ceiling suspended	PCA-A**KA6.TH						●		
Multi-position	MVZ-A**AA4			●		●	●		
	SVZ-KP**NA			●		●	●		

<MXZ-4C36NA3-U1, MXZ-4C36NA4-U1>

Connectable indoor unit lineups (Heat pump inverter type)		Capacity class [kBTU/h]							
Model type	Model name	06	09	12	15	18	24	30	36
Wall mounted	MSZ-FE**NA		●	●					
	MSZ-FH**NA	●	●	●	●	●			
	MSZ-FH**NA2								
	MSZ-FS**NA	●	●	●	●	●			
	MSZ-GE**NA	●	●	●	●	●	●		
	MSZ-GL**NA-U1	●	●	●	●	●	●		
	MSZ-GS**NA-U1	●	●	●	●	●	●		
Floor standing	MFZ-KA**NA		●	●		●			
	MFZ-KJ**NA-U1		●	●	●	●			
4-way cassette	SLZ-KA**NA.TH		●	●	●				
	SLZ-KF**NA.TH		●	●	●				
	PLA-A**BA6					●	●		
	PLA-A**EA7					●			
1-way cassette	MLZ-KP**NA-U1		●	●		●			
	MLZ-KP**NA2-U1		●	●		●			
	MLZ-KY**NA-U1	●							
Ceiling concealed	SEZ-KD**NA4.TH		●	●	●	●			
	PEAD-A**AA7		●	●	●	●	●		
Ceiling suspended	PCA-A**KA7.TH						●		
Multi-position	MVZ-A**AA4			●		●	●		
	SVZ-KP**NA			●		●	●		
	PAA-A**					●	●		

<MXZ-5C42NA3-U1, MXZ-5C42NA4-U1>

Connectable indoor unit lineups (Heat pump inverter type)		Capacity class [kBTU/h]							
Model type	Model name	06	09	12	15	18	24	30	36
Wall mounted	MSZ-FE**NA		●	●					
	MSZ-FH**NA	●	●	●	●	●			
	MSZ-FH**NA2								
	MSZ-FS**NA	●	●	●	●	●			
	MSZ-GE**NA	●	●	●	●	●	●		
	MSZ-GL**NA-U1	●	●	●	●	●	●		
	MSZ-GS**NA-U1	●	●	●	●	●	●		
Floor standing	MFZ-KA**NA		●	●		●			
	MFZ-KJ**NA-U1		●	●	●	●			
4-way cassette	SLZ-KA**NA.TH		●	●	●				
	SLZ-KF**NA.TH		●	●	●				
	PLA-A**BA6					●	●		
	PLA-A**EA7					●			
1-way cassette	MLZ-KP**NA-U1		●	●		●			
	MLZ-KP**NA2-U1		●	●		●			
	MLZ-KY**NA-U1	●							
Ceiling concealed	SEZ-KD**NA4.TH		●	●	●	●			
	PEAD-A**AA7		●	●	●	●	●		
Ceiling suspended	PCA-A**KA7.TH						●		
Multi-position	MVZ-A**AA4			●		●	●		
	SVZ-KP**NA			●		●	●		
	PAA-A**					●	●		

<MXZ-5C42NA>

Connectable indoor unit lineups (Heat pump inverter type)		Capacity class [kBTU/h]							
Model type	Model name	06	09	12	15	18	24	30	36
Wall mounted	MSZ-FE**NA		●	●					
	MSZ-FH**NA	●	●	●	●	●			
	MSZ-FH**NA2								
	MSZ-FS**NA								
	MSZ-GE**NA	●	●	●	●	●	●		
	MSZ-GL**NA-U1	●	●	●	●	●	●		
	MSZ-EF**NA-U1		●	●	●	●			
Floor standing	MFZ-KA**NA		●	●		●			
	MFZ-KJ**NA-U1		●	●	●	●			
4-way cassette	SLZ-KA**NA.TH		●	●	●				
	SLZ-KF**NA.TH		●	●	●				
	PLA-A**BA6					●	●		
	PLA-A**EA7					●			
Ceiling concealed	SEZ-KD**NA4.TH		●	●	●	●			
	PEAD-A**AA5		●	●	●	●	●		
Ceiling suspended	PCA-A**KA6.TH						●		
Multi-position	MVZ-A**AA4			●		●	●		
	SVZ-KP**NA			●		●	●		

MXZ-5C42NA
MXZ-2C20NAHZ
MXZ-3C24NAHZ
MXZ-3C30NAHZ

1. New model

MXZ-3C24NA
MXZ-3C30NA
MXZ-4C36NA

1. New model

MXZ-3C24NA → MXZ-3C24NA2-^{U1}
MXZ-3C30NA → MXZ-3C30NA2-^{U1}
MXZ-4C36NA → MXZ-4C36NA2-^{U1}
MXZ-5C42NA → MXZ-5C42NA2-^{U1}

1. Outdoor control P.C. board has been changed.

MXZ-2C20NA2-^{U1}

1. New model

MXZ-2C20NA2-^{U1} → MXZ-2C20NA2-^{U4}

1. Outdoor fan motor has been changed.

2. Outdoor control P.C. board has been changed.

MXZ-2C20NA2-^{U4} → MXZ-2C20NA3-^{U1}
MXZ-3C24NA2-^{U1} → MXZ-3C24NA3-^{U1}
MXZ-3C30NA2-^{U1} → MXZ-3C30NA3-^{U1}
MXZ-4C36NA2-^{U1} → MXZ-4C36NA3-^{U1}
MXZ-5C42NA2-^{U1} → MXZ-5C42NA3-^{U1}

1. Outdoor fan motor has been changed.

2. Outdoor control P.C. board has been changed.

MXZ-2C20NA3-^{U1} → MXZ-2C20NA4-^{U1}
MXZ-3C24NA3-^{U1} → MXZ-3C24NA4-^{U1}
MXZ-3C30NA3-^{U1} → MXZ-3C30NA4-^{U1}
MXZ-4C36NA3-^{U1} → MXZ-4C36NA4-^{U1}
MXZ-5C42NA3-^{U1} → MXZ-5C42NA4-^{U1}

1. Outdoor control P.C. board has been changed.

MXZ-2C20NAHZ → MXZ-2C20NAHZ2-^{U1}
MXZ-3C24NAHZ → MXZ-3C24NAHZ2-^{U1}
MXZ-3C30NAHZ → MXZ-3C30NAHZ2-^{U1}

MXZ-2C20NAHZ2-^{U1} → MXZ-2C20NAHZ3-^{U1}
MXZ-3C24NAHZ2-^{U1} → MXZ-3C24NAHZ3-^{U1}
MXZ-3C30NAHZ2-^{U1} → MXZ-3C30NAHZ3-^{U1}

MXZ-2C20NAHZ3-^{U1} → MXZ-2C20NAHZ4-^{U1}
MXZ-3C24NAHZ3-^{U1} → MXZ-3C24NAHZ4-^{U1}
MXZ-3C30NAHZ3-^{U1} → MXZ-3C30NAHZ4-^{U1}

2-1. ALWAYS OBSERVE FOR SAFETY

Before obtaining access to terminal, all supply circuit must be disconnected.

Preparation before the repair service

- Prepare the proper tools.
- Prepare the proper protectors.
- Provide adequate ventilation.
- After stopping the operation of the air conditioner, turn off the power-supply breaker.
- Discharge the condenser before the work involving the electric parts.

Precautions during the repair service

- Do not perform the work involving the electric parts with wet hands.
- Do not pour water into electric parts.
- Do not touch the refrigerant.
- Do not touch the hot or cold areas in the refrigerating cycle.
- When the repair or the inspection of the circuit needs to be done without turning off the power, exercise great caution not to touch the live parts.
- When opening or closing the valve below freezing temperatures, refrigerant may spurt out from the gap between the valve stem and the valve body, resulting in injuries.

2-2. CAUTIONS RELATED TO R410A REFRIGERANT

Caution for units utilizing refrigerant R410A

Make sure that the inside and outside of refrigerant piping is clean and it has no contaminants such as sulfur, oxides, dirt, shaving particles, etc., which are hazardous to the refrigerant cycle. In addition, use pipes with specified thickness.

Contamination inside refrigerant piping can cause deterioration of refrigerant oil, etc.

Store the piping indoors, and keep both ends of the piping sealed until just before brazing. (Leave elbow joints, etc. in their packaging.)

If dirt, dust or moisture enters into the refrigerant cycle, that can cause deterioration of refrigerant oil or malfunction of the compressor.

The refrigerant oil applied to flare and flange connections must be ester oil, ether oil or alkylbenzene oil in a small amount.

If a large amount of mineral oil enters, that can cause deterioration of refrigerant oil, etc.

Charge refrigerant from the liquid phase of the gas cylinder.

If the refrigerant is charged from the gas phase, composition change may occur in the refrigerant and the efficiency will be lowered.

Do not use refrigerant other than R410A.

If other refrigerant (R22, etc.) is used, chlorine in the refrigerant can cause deterioration of refrigerant oil, etc.

Use a vacuum pump with a reverse flow check valve.

Vacuum pump oil may flow back into the refrigerant cycle and that can cause deterioration of refrigerant oil, etc.

Use the following tools specifically designed for use with R410A refrigerant.

The following tools are necessary to use R410A refrigerant.

Tools for R410A	
Gauge manifold	Flare tool
Charge hose	Size adjustment gauge
Gas leak detector	Vacuum pump adaptor
Torque wrench	Electronic refrigerant charging scale

Handle tools with care.

If dirt, dust or moisture enters into the refrigerant cycle, that can cause deterioration of refrigerant oil or malfunction of the compressor.

Use the specified refrigerant only.

Never use any refrigerant other than that specified.

Doing so may cause a burst, an explosion, or fire when the unit is being used, serviced, or disposed of. Correct refrigerant is specified in the manuals and on the spec labels provided with our products.

We will not be held responsible for mechanical failure, system malfunction, unit breakdown or accidents caused by failure to follow the instructions.

Do not use a charging cylinder.

If a charging cylinder is used, the composition of the refrigerant will change and the efficiency will be lowered.

Ventilate the room if refrigerant leaks during operation. If refrigerant comes into contact with a flame, poisonous gases will be released.

[1] Cautions for service

- (1) Perform service after recovering the refrigerant left in unit completely.
- (2) Do not release refrigerant in the air.
- (3) After completing service, charge the cycle with specified amount of refrigerant.
- (4) If moisture or foreign matter might have entered the refrigerant piping during service, ensure to remove them.

[2] Additional refrigerant charge

When charging directly from cylinder

- (1) Check that cylinder for R410A on the market is a siphon type.
- (2) Charging should be performed with the cylinder of siphon stood vertically. (Refrigerant is charged from liquid phase.)

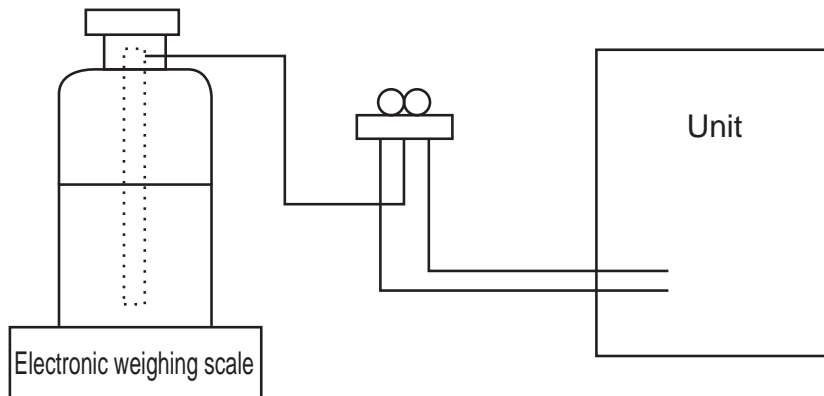

[3] Service tools

- (1) Use the below service tools as exclusive tools for R410A refrigerant.

No.	Tool name	Specifications
1	Gauge manifold	·Only for R410A ·Use the existing fitting specifications. (UNF1/2) ·Use high-tension side pressure of 768.7 PSIG [5.3 MPaG] or over.
2	Charge hose	·Only for R410A ·Use pressure performance of 738.2 PSIG [5.09MPaG] or over.
3	Electronic weighing scale	—
4	Gas leak detector	·Use the detector for R134a, R407C or R410A.
5	Adaptor for reverse flow check	·Attach on vacuum pump.
6	Refrigerant charge base	—
7	Refrigerant cylinder	·Only for R410A ·Top of cylinder (Pink) ·Cylinder with siphon
8	Refrigerant recovery equipment	—

2-3. Cautions for refrigerant piping work

Refrigerant R410A is adopted for replacement inverter series. Although the refrigerant piping work for R410A is the same as for R22, exclusive tools are necessary so as not to mix with different kind of refrigerant. Furthermore as the working pressure of R410A is 1.6 times higher than that of R22, their sizes of flared sections and flare nuts are different.

① Thickness of pipes

Since the working pressure of R410A is higher compared to R22, be sure to use refrigerant piping with thickness shown below. (Never use pipes of 7/256 in [0.7 mm] or below.)

Diagram below: Piping diameter and thickness

Nominal dimensions (inch)	Outside diameter (mm)	Thickness: in [mm]	
		R410A	R22
1/4	6.35	1/32 [0.8]	1/32 [0.8]
3/8	9.52	1/32 [0.8]	1/32 [0.8]
1/2	12.70	1/32 [0.8]	1/32 [0.8]
5/8	15.88	5/128 [1.0]	5/128 [1.0]
3/4	19.05	—	5/128 [1.0]

② Dimensions of flare cutting and flare nut

The component molecules in HFC refrigerant are smaller compared to conventional refrigerants. In addition to that, R410A is a refrigerant, which has higher risk of leakage because its working pressure is higher than that of other refrigerants. Therefore, to enhance airtightness and strength, flare cutting dimension of copper pipe for R410A has been specified separately from the dimensions for other refrigerants as shown below. The dimension B of flare nut for R410A also has partly been changed to increase strength as shown below. Set copper pipe correctly referring to copper pipe flaring dimensions for R410A below. For 1/2 and 5/8 inch pipes, the dimension B changes.

Use torque wrench corresponding to each dimension.

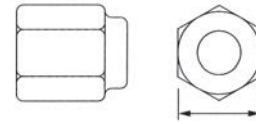
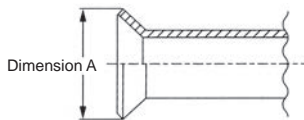

Dimension B

Flare cutting dimensions Unit: in [mm]

Nominal dimensions (in)	Outside diameter (mm)	Dimension A ⁽⁺⁰⁾ _(-0.4)	
		R410A	R22
1/4	6.35	11/32-23/64 [9.1]	9.0
3/8	9.52	1/2-33/64 [13.2]	13.0
1/2	12.70	41/64-21/32 [16.6]	16.2
5/8	15.88	49/64-25/32 [19.7]	19.4
3/4	19.05	—	23.3

Flare nut dimensions Unit: in [mm]

Nominal dimensions (in)	Outside diameter (mm)	Dimension B	
		R410A	R22
1/4	6.35	43/64 [17.0]	17.0
3/8	9.52	7/8 [22.0]	22.0
1/2	12.70	1-3/64 [26.0]	24.0
5/8	15.88	1-9/64 [29.0]	27.0
3/4	19.05	—	36.0

③ Tools for R410A (The following table shows whether conventional tools can be used or not.)

Tools and materials	Use	R410A tools	Can R22 tools be used?	Can R407C tools be used?
Gauge manifold	Air purge, refrigerant charge and operation check	Tool exclusive for R410A	×	×
Charge hose		Tool exclusive for R410A	×	×
Gas leak detector	Gas leak check	Tool for HFC refrigerant	×	○
Refrigerant recovery equipment	Refrigerant recovery	Tool exclusive for R410A	×	×
Refrigerant cylinder	Refrigerant charge	Tool exclusive for R410A	×	×
Applied oil	Apply to flared section	Ester oil, ether oil and alkylbenzene oil (minimum amount)	×	Ester oil, ether oil: ○ Alkylbenzene oil: minimum amount
Safety charger	Prevent compressor malfunction when charging refrigerant by spraying liquid refrigerant	Tool exclusive for R410A	×	×
Charge valve	Prevent gas from blowing out when detaching charge hose	Tool exclusive for R410A	×	×
Vacuum pump	Vacuum drying and air purge	Tools for other refrigerants can be used if equipped with adopter for reverse flow check	△(Usable if equipped with adopter for reverse flow)	△(Usable if equipped with adopter for reverse flow)
Flare tool	Flaring work of piping	Tools for other refrigerants can be used by adjusting flaring dimension	△(Usable by adjusting flaring dimension)	△(Usable by adjusting flaring dimension)
Bender	Bend the pipes	Tools for other refrigerants can be used	○	○
Pipe cutter	Cut the pipes	Tools for other refrigerants can be used	○	○
Welder and nitrogen gas cylinder	Weld the pipes	Tools for other refrigerants can be used	○	○
Refrigerant charging scale	Refrigerant charge	Tools for other refrigerants can be used	○	○
Vacuum gauge or thermistor vacuum gauge and vacuum valve	Check the degree of vacuum. (Vacuum valve prevents back flow of oil and refrigerant to thermistor vacuum gauge)	Tools for other refrigerants can be used	○	○
Charging cylinder	Refrigerant charge	Tool exclusive for R410A	×	—

- ×: Prepare a new tool. (Use the new tool as the tool exclusive for R410A.)
- △: Tools for other refrigerants can be used under certain conditions.
- : Tools for other refrigerants can be used.

3

PART NAMES AND FUNCTIONS

MXZ-2C20NA2 MXZ-2C20NA3 MXZ-2C20NA4

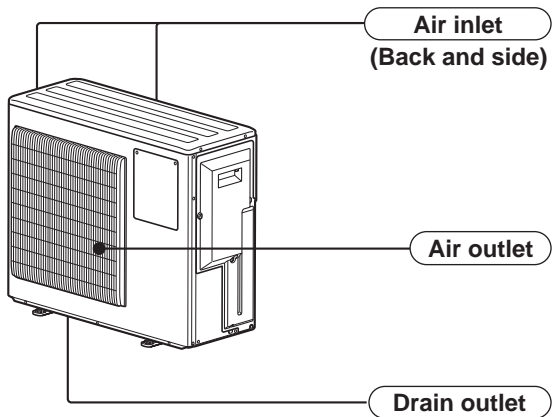

MXZ-3C24NA MXZ-3C24NA2 MXZ-3C24NA3 MXZ-3C24NA4
MXZ-3C30NA MXZ-3C30NA2 MXZ-3C30NA3 MXZ-3C30NA4
MXZ-4C36NA MXZ-4C36NA2 MXZ-4C36NA3 MXZ-4C36NA4

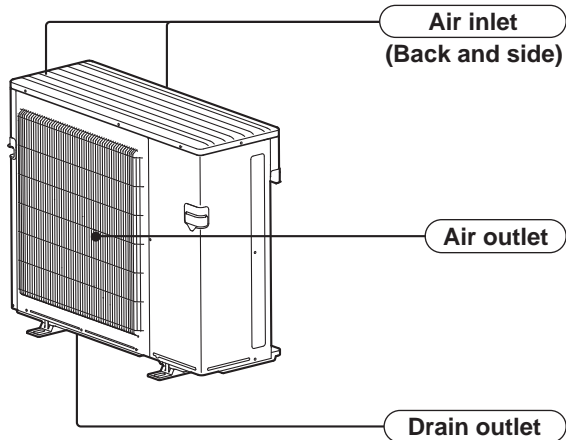

MXZ-5C42NA MXZ-5C42NA2 MXZ-5C42NA3 MXZ-5C42NA4
MXZ-2C20NAHZ MXZ-2C20NAHZ2 MXZ-2C20NAHZ3 MXZ-2C20NAHZ4
MXZ-3C24NAHZ MXZ-3C24NAHZ2 MXZ-3C24NAHZ3 MXZ-3C24NAHZ4
MXZ-3C30NAHZ MXZ-3C30NAHZ2 MXZ-3C30NAHZ3 MXZ-3C30NAHZ4

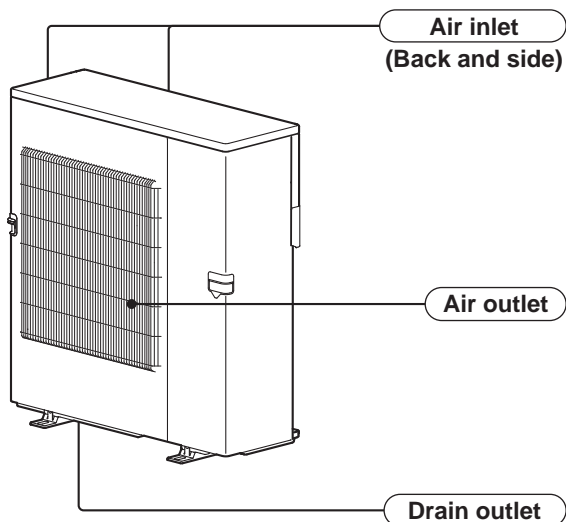

4

SPECIFICATION

Item		Outdoor model		MXZ-2C20NA2 MXZ-2C20NA3	
		Indoor type		Non-Duct (09+09)	Duct (09+12)
Capacity	Cooling *1	Btu/h	18,000	20,000	
	Heating 47 *1	Btu/h	22,000	22,000	
	Heating 17 *2	Btu/h	15,500	14,500	
Power consumption	Cooling *1	W	1,417	2,000	
	Heating 47 *1	W	1,641	1,771	
	Heating 17 *2	W	1,750	1,810	
EER	Cooling		12.7	10.0	
SEER	Cooling		20.0	16.0	
HSPF IV(V)	Heating		10.0	9.3	
COP	Heating		3.93	3.64	
External finish		Munsell 3.0Y 7.8/1.1			
Power supply		V, phase, Hz	208/230, 1, 60		
Max. fuse size (time delay)		A	20		
Min. circuit ampacity		A	17.2		
Fan motor		F.L.A	1.77		
Compressor	Model	SNB140FQUH2T			
	Winding resistance (at 68 °F)	Ω	U-V1.99 V-W 1.99 W-U 1.99		
		R.L.A	10.7		
		L.R.A	15.5		
Refrigerant control			LEV		
Sound level		dB(A)	50/54		
Defrost method			Reverse cycle		
Dimensions	W	in.	33-1/16		
	D	in.	13		
	H	in.	27-15/16		
Weight		lb.	126		
Remote controller			Wireless type		
Control voltage (by built-in transformer)			12 - 24 V DC		
Refrigerant piping			Not supplied (optional parts)		
Valve size	Liquid	in.	1/4		
	Gas	in.	3/8		
Connection method	Indoor		Flared		
	Outdoor		Flared		
Refrigerant charge (R410A)		lb.	5 lb. 15 oz.		
Refrigeration oil (Model)		fl oz. (L)	20.3 (0.6) (NEO22)		

NOTE: Test conditions are based on ARI 210/240.

Unit: °F

Mode	Test	Indoor air condition		Outdoor air condition	
		Dry bulb	Wet bulb	Dry bulb	Wet bulb
Cooling	*1: "A" Cooling steady state at rated compressor speed	80	67	95	(75)
	"B-2" Cooling steady state at rated compressor speed	80	67	82	(65)
	"B-1" Cooling steady state at minimum compressor speed	80	67	82	(65)
	Low ambient cooling steady state at minimum compressor speed	80	67	67	(53.5)
	Intermediate cooling steady state at intermediate compressor speed	80	67	87	(69)
Heating	*1: Standard rating-heating at rated compressor speed	70	60	47	43
	*2: Low temperature heating at maximum compressor speed	70	60	17	15
	Maximum temperature heating at minimum compressor speed	70	60	62	56.5
	High temperature heating at minimum compressor speed	70	60	47	43
	Frost accumulation at rated compressor speed	70	60	35	33
	Frost accumulation at intermediate compressor speed	70	60	35	33

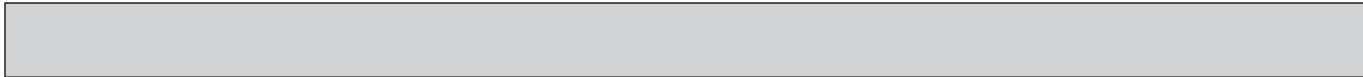

Item		Outdoor model		MXZ-2C20NA4	
		Indoor type		Non-Duct (09+09)	Duct (09+12)
Capacity	Cooling *1	Btu/h		18,000	20,000
	Heating 47 *1	Btu/h		22,000	22,000
	Heating 17 *2	Btu/h		15,500	14,500
Power consumption	Cooling *1	W		1,417	2,000
	Heating 47 *1	W		1,641	1,771
	Heating 17 *2	W		1,750	1,810
EER2	Cooling		12.7	10.0	
SEER2	Cooling		20.0	16.0	
HSPF2	Heating		12.0	9.1	
COP2	Heating		3.92	3.64	
External finish			Munsell 3.0Y 7.8/1.1		
Power supply		V, phase, Hz		208/230, 1, 60	
Max. fuse size (time delay)		A		20	
Min. circuit ampacity		A		17.2	
Fan motor		F.L.A		1.77	
Compressor	Model		SNB140FQUH2T		
	Winding resistance (at 68 °F)		Ω	U-V 1.99 V-W 1.99 W-U 1.99	
			R.L.A	10.7	
			L.R.A	15.5	
Refrigerant control			LEV		
Sound level		dB(A)		50/54	
Defrost method			Reverse cycle		
Dimensions	W	in.		33-1/16	
	D	in.		13	
	H	in.		27-15/16	
Weight		lb.		126	
Remote controller			Wireless type		
Control voltage (by built-in transformer)			12 - 24 V DC		
Refrigerant piping			Not supplied (optional parts)		
Valve size	Liquid	in.		1/4	
	Gas	in.		3/8	
Connection method	Indoor		Flared		
	Outdoor		Flared		
Refrigerant charge (R410A)		lb.		5 lb. 15 oz.	
Refrigeration oil (Model)		fl oz. (L)		20.3 (0.6) (NEO22)	

NOTE: Test conditions are based on ARI 210/240.

Unit: °F

Mode	Test	Indoor air condition		Outdoor air condition	
		Dry bulb	Wet bulb	Dry bulb	Wet bulb
Cooling	*1: "A" Cooling steady state at rated compressor speed	80	67	95	(75)
	"B-2" Cooling steady state at rated compressor speed	80	67	82	(65)
	"B-1" Cooling steady state at minimum compressor speed	80	67	82	(65)
	Low ambient cooling steady state at minimum compressor speed	80	67	67	(53.5)
	Intermediate cooling steady state at intermediate compressor speed	80	67	87	(69)
Heating	*1: Standard rating-heating at rated compressor speed	70	60	47	43
	*2: Low temperature heating at maximum compressor speed	70	60	17	15
	Maximum temperature heating at minimum compressor speed	70	60	62	56.5
	High temperature heating at minimum compressor speed	70	60	47	43
	Frost accumulation at rated compressor speed	70	60	35	33
	Frost accumulation at intermediate compressor speed	70	60	35	33

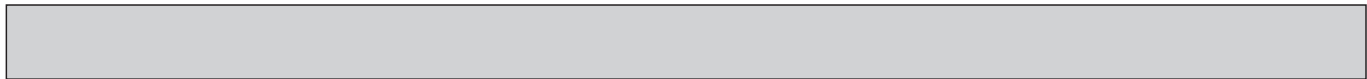

Item		Outdoor model		MXZ-3C24NA MXZ-3C24NA2 MXZ-3C24NA3	
		Indoor type		Non-Duct (06+09+09)	Duct (09+09+09)
Capacity	Cooling *1	Btu/h	22,000	23,600	
	Heating 47 *1	Btu/h	25,000	24,600	
	Heating 17 *2	Btu/h	19,600	19,600	
Power consumption	Cooling *1	W	1,620	2,100	
	Heating 47 *1	W	1,750	1,900	
	Heating 17 *2	W	2,580	2,440	
EER	Cooling		13.6	11.2	
SEER	Cooling		20.0	16.0	
HSPF IV(V)	Heating		10.0 (7.6)	9.2 (7.6)	
COP	Heating		4.20	3.80	
External finish		Munsell 3.0Y 7.8/1.1			
Power supply		V, phase, Hz	208/230, 1, 60		
Max. fuse size (time delay)		A	25		
Min. circuit ampacity		A	22.1		
Fan motor		F.L.A	2.43		
Compressor	Model		SNB220FQGMC		
	Winding resistance (at 68 °F)	Ω	U-V 0.95 V-W 0.95 W-U 0.95		
		R.L.A	12		
		L.R.A	13.7		
Refrigerant control			LEV		
Sound level		dB(A)	51/55		
Defrost method			Reverse cycle		
Dimensions	W	in.	37-13/32		
	D	in.	13		
	H	in.	31-11/32		
Weight		lb.	NA: 135 / NA2, NA3: 137		
Remote controller			Wireless type		
Control voltage (by built-in transformer)			12-24 V DC		
Refrigerant piping			Not supplied (optional parts)		
Valve size	Liquid	in.	1/4		
	Gas	in.	A:1/2 B,C:3/8		
Connection method	Indoor		Flared		
	Outdoor		Flared		
Refrigerant charge (R410A)		lb.	6lb. 13oz.		
Refrigeration oil (Model)		fl oz. (L)	23.7 (0.7) NA, NA2: (FV50S) / NA3: (FV50S/FW68S)		

NOTE: Test conditions are based on ARI 210/240.

Unit: °F

Mode	Test	Indoor air condition		Outdoor air condition	
		Dry bulb	Wet bulb	Dry bulb	Wet bulb
Cooling	*1: "A" Cooling steady state at rated compressor speed	80	67	95	(75)
	"B-2" Cooling steady state at rated compressor speed	80	67	82	(65)
	"B-1" Cooling steady state at minimum compressor speed	80	67	82	(65)
	Low ambient cooling steady state at minimum compressor speed	80	67	67	(53.5)
	Intermediate cooling steady state at intermediate compressor speed	80	67	87	(69)
Heating	*1: Standard rating-heating at rated compressor speed	70	60	47	43
	*2: Low temperature heating at maximum compressor speed	70	60	17	15
	Maximum temperature heating at minimum compressor speed	70	60	62	56.5
	High temperature heating at minimum compressor speed	70	60	47	43
	Frost accumulation at rated compressor speed	70	60	35	33
	Frost accumulation at intermediate compressor speed	70	60	35	33

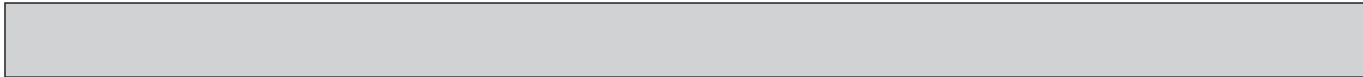

Item		Outdoor model	MXZ-3C24NA4		
		Indoor type	Non-Duct (06+09+09)		Duct (09+09+09)
Capacity	Cooling *1	Btu/h	22,000	23,600	
	Heating 47 *1	Btu/h	25,000	24,600	
	Heating 17 *2	Btu/h	21,000	21,000	
Power consumption	Cooling *1	W	1,610	2,100	
	Heating 47 *1	W	1,740	1,890	
	Heating 17 *2	W	2,860	2,960	
EER2	Cooling		13.60	11.20	
SEER2	Cooling		20.00	16.00	
HSPF2	Heating		10.00	8.60	
COP2	Heating		4.20	3.80	
External finish			Munsell 3.0Y 7.8/1.1		
Power supply		V, phase, Hz	208/230, 1, 60		
Max. fuse size (time delay)		A	25		
Min. circuit ampacity		A	22.1		
Fan motor		F.L.A	2.43		
Compressor	Model		SNB220FCGMC		
	Winding resistance (at 68 °F)	Ω	U-V 0.95 V-W 0.95 W-U 0.95		
		R.L.A	12		
		L.R.A	13.7		
Refrigerant control			LEV		
Sound level		dB(A)	51/55		
Defrost method			Reverse cycle		
Dimensions	W	in.	37-13/32		
	D	in.	13		
	H	in.	31-11/32		
Weight		lb.	142		
Remote controller			Wireless type		
Control voltage (by built-in transformer)			12-24 V DC		
Refrigerant piping			Not supplied (optional parts)		
Valve size	Liquid	in.	1/4		
	Gas	in.	A:1/2 B,C:3/8		
Connection method	Indoor		Flared		
	Outdoor		Flared		
Refrigerant charge (R410A)		lb.	6lb. 13oz.		
Refrigeration oil (Model)		fl oz. (L)	23.7 (0.7) (FV50S/FW68S)		

NOTE: Test conditions are based on ARI 210/240.

Unit: °F

Mode	Test	Indoor air condition		Outdoor air condition	
		Dry bulb	Wet bulb	Dry bulb	Wet bulb
Cooling	*1: "A" Cooling steady state at rated compressor speed	80	67	95	(75)
	"B-2" Cooling steady state at rated compressor speed	80	67	82	(65)
	"B-1" Cooling steady state at minimum compressor speed	80	67	82	(65)
	Low ambient cooling steady state at minimum compressor speed	80	67	67	(53.5)
	Intermediate cooling steady state at intermediate compressor speed	80	67	87	(69)
Heating	*1: Standard rating-heating at rated compressor speed	70	60	47	43
	*2: Low temperature heating at maximum compressor speed	70	60	17	15
	Maximum temperature heating at minimum compressor speed	70	60	62	56.5
	High temperature heating at minimum compressor speed	70	60	47	43
	Frost accumulation at rated compressor speed	70	60	35	33
	Frost accumulation at intermediate compressor speed	70	60	35	33

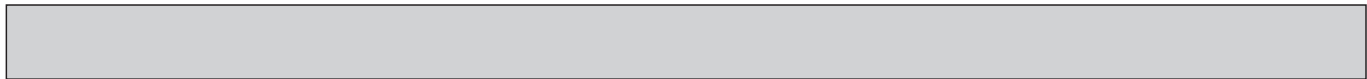

Item		Outdoor model		MXZ-3C30NA MXZ-3C30NA2 MXZ-3C30NA3	
		Indoor type		Non-Duct (09+09+12)	Duct (09+09+12)
Capacity	Cooling *1	Btu/h	28,400	27,400	
	Heating 47 *1	Btu/h	28,600	27,600	
	Heating 17 *2	Btu/h	21,000	21,000	
Power consumption	Cooling *1	W	2,680	2,840	
	Heating 47 *1	W	2,150	2,220	
	Heating 17 *2	W	2,740	2,820	
EER	Cooling		10.6	9.6	
SEER	Cooling		19.0	16.2	
HSPF IV(V)	Heating		10.6 (8.0)	9.6 (8.0)	
COP	Heating		3.90	3.64	
External finish		Munsell 3.0Y 7.8/1.1			
Power supply		V, phase, Hz	208/230, 1, 60		
Max. fuse size (time delay)		A	25		
Min. circuit ampacity		A	22.1		
Fan motor		F.L.A	2.43		
Compressor	Model		SNB220FQGM C		
	Winding resistance (at 68 °F)	Ω	U-V 0.95 V-W 0.95 W-U 0.95		
		R.L.A	12		
		L.R.A	13.7		
Refrigerant control			LEV		
Sound level		dB(A)	52/56		
Defrost method			Reverse cycle		
Dimensions	W	in.	37-13/32		
	D	in.	13		
	H	in.	31-11/32		
Weight		lb.	NA: 135 / NA2, NA3: 137		
Remote controller			Wireless type		
Control voltage (by built-in transformer)			12-24 V DC		
Refrigerant piping			Not supplied (optional parts)		
Valve size	Liquid	in.	1/4		
	Gas	in.	A:1/2 B,C:3/8		
Connection method	Indoor		Flared		
	Outdoor		Flared		
Refrigerant charge (R410A)		lb.	6lb. 13oz.		
Refrigeration oil (Model)		fl oz. (L)	23.7 (0.7) NA, NA2: (FV50S) / NA3: (FV50S/FW68S)		

NOTE: Test conditions are based on ARI 210/240.

Unit: °F

Mode	Test	Indoor air condition		Outdoor air condition	
		Dry bulb	Wet bulb	Dry bulb	Wet bulb
Cooling	*1: "A" Cooling steady state at rated compressor speed	80	67	95	(75)
	"B-2" Cooling steady state at rated compressor speed	80	67	82	(65)
	"B-1" Cooling steady state at minimum compressor speed	80	67	82	(65)
	Low ambient cooling steady state at minimum compressor speed	80	67	67	(53.5)
	Intermediate cooling steady state at intermediate compressor speed	80	67	87	(69)
Heating	*1: Standard rating-heating at rated compressor speed	70	60	47	43
	*2: Low temperature heating at maximum compressor speed	70	60	17	15
	Maximum temperature heating at minimum compressor speed	70	60	62	56.5
	High temperature heating at minimum compressor speed	70	60	47	43
	Frost accumulation at rated compressor speed	70	60	35	33
	Frost accumulation at intermediate compressor speed	70	60	35	33



Item		Outdoor model	MXZ-3C30NA4		
		Indoor type	Non-Duct (09+09+12)		Duct (09+09+12)
Capacity	Cooling *1	Btu/h	28,400		27,400
	Heating 47 *1	Btu/h	28,600		27,600
	Heating 17 *2	Btu/h	21,000		21,000
Power consumption	Cooling *1	W	2,670		2,840
	Heating 47 *1	W	2,149		2,220
	Heating 17 *2	W	2,860		2,960
EER2	Cooling		10.60		9.60
SEER2	Cooling		19.00		16.20
HSPF2	Heating		10.00		8.80
COP2	Heating		3.90		3.60
External finish			Munsell 3.0Y 7.8/1.1		
Power supply		V, phase, Hz	208/230, 1, 60		
Max. fuse size (time delay)		A	25		
Min. circuit ampacity		A	22.1		
Fan motor		F.L.A	2.43		
Compressor	Model		SNB220FCGMC		
	Winding resistance (at 68 °F)	Ω	U-V 0.95 V-W 0.95 W-U 0.95		
		R.L.A	12		
		L.R.A	13.7		
Refrigerant control			LEV		
Sound level		dB(A)	52/56		
Defrost method			Reverse cycle		
Dimensions	W	in.	37-13/32		
	D	in.	13		
	H	in.	31-11/32		
Weight		lb.	142		
Remote controller			Wireless type		
Control voltage (by built-in transformer)			12-24 V DC		
Refrigerant piping			Not supplied (optional parts)		
Valve size	Liquid	in.	1/4		
	Gas	in.	A:1/2 B,C:3/8		
Connection method	Indoor		Flared		
	Outdoor		Flared		
Refrigerant charge (R410A)		lb.	6lb. 13oz.		
Refrigeration oil (Model)		fl oz. (L)	23.7 (0.7) (FV50S/FW68S)		

NOTE: Test conditions are based on ARI 210/240.

Unit: °F

Mode	Test	Indoor air condition		Outdoor air condition	
		Dry bulb	Wet bulb	Dry bulb	Wet bulb
Cooling	*1: "A" Cooling steady state at rated compressor speed	80	67	95	(75)
	"B-2" Cooling steady state at rated compressor speed	80	67	82	(65)
	"B-1" Cooling steady state at minimum compressor speed	80	67	82	(65)
	Low ambient cooling steady state at minimum compressor speed	80	67	67	(53.5)
	Intermediate cooling steady state at intermediate compressor speed	80	67	87	(69)
Heating	*1: Standard rating-heating at rated compressor speed	70	60	47	43
	*2: Low temperature heating at maximum compressor speed	70	60	17	15
	Maximum temperature heating at minimum compressor speed	70	60	62	56.5
	High temperature heating at minimum compressor speed	70	60	47	43
	Frost accumulation at rated compressor speed	70	60	35	33
	Frost accumulation at intermediate compressor speed	70	60	35	33



Item		Outdoor model		MXZ-4C36NA MXZ-4C36NA2 MXZ-4C36NA3	
		Indoor type		Non-Duct (09+09+09+09)	Duct (09+09+09+09)
Capacity	Cooling *1	Btu/h	35,400	34,400	
	Heating 47 *1	Btu/h	36,000	34,400	
	Heating 17 *2	Btu/h	26,600	26,600	
Power consumption	Cooling *1	W	3,760	3,940	
	Heating 47 *1	W	3,020	3,100	
	Heating 17 *2	W	3,440	3,540	
EER	Cooling		9.4	8.7	
SEER	Cooling		19.2	16.0	
HSPF IV(V)	Heating		11.0 (8.4)	9.8 (8.4)	
COP	Heating		3.50	3.25	
External finish		Munsell 3.0Y 7.8/1.1			
Power supply		V, phase, Hz	208/230, 1, 60		
Max. fuse size (time delay)		A	25		
Min. circuit ampacity		A	23.1		
Fan motor		F.L.A	2.43		
Compressor	Model		SNB220FQGM C		
	Winding resistance (at 68 °F)	Ω	U-V 0.95 V-W 0.95 W-U 0.95		
		R.L.A	12		
		L.R.A	13.7		
Refrigerant control			LEV		
Sound level		dB(A)	54/56		
Defrost method			Reverse cycle		
Dimensions	W	in.	37-13/32		
	D	in.	13		
	H	in.	31-11/32		
Weight		lb.	NA: 137 / NA2, NA3: 139		
Remote controller			Wireless type		
Control voltage (by built-in transformer)			12-24 V DC		
Refrigerant piping			Not supplied (optional parts)		
Valve size	Liquid	in.	1/4		
	Gas	in.	A:1/2 B,C,D:3/8		
Connection method	Indoor		Flared		
	Outdoor		Flared		
Refrigerant charge (R410A)		lb.	6lb. 13oz.		
Refrigeration oil (Model)		fl oz. (L)	23.7 (0.7) NA, NA2: (FV50S) / NA3: (FV50S/FW68S)		

NOTE: Test conditions are based on ARI 210/240.

Unit: °F

Mode	Test	Indoor air condition		Outdoor air condition	
		Dry bulb	Wet bulb	Dry bulb	Wet bulb
Cooling	*1: "A" Cooling steady state at rated compressor speed	80	67	95	(75)
	"B-2" Cooling steady state at rated compressor speed	80	67	82	(65)
	"B-1" Cooling steady state at minimum compressor speed	80	67	82	(65)
	Low ambient cooling steady state at minimum compressor speed	80	67	67	(53.5)
	Intermediate cooling steady state at intermediate compressor speed	80	67	87	(69)
Heating	*1: Standard rating-heating at rated compressor speed	70	60	47	43
	*2: Low temperature heating at maximum compressor speed	70	60	17	15
	Maximum temperature heating at minimum compressor speed	70	60	62	56.5
	High temperature heating at minimum compressor speed	70	60	47	43
	Frost accumulation at rated compressor speed	70	60	35	33
	Frost accumulation at intermediate compressor speed	70	60	35	33

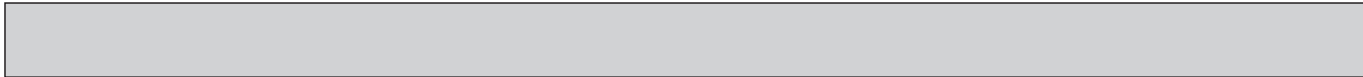

Item		Outdoor model	MXZ-4C36NA4		
		Indoor type	Non-Duct (09+09+09+09)		Duct (09+09+09+09)
Capacity	Cooling *1	Btu/h	35,400		34,400
	Heating 47 *1	Btu/h	36,000		34,400
	Heating 17 *2	Btu/h	26,600		26,600
Power consumption	Cooling *1	W	3,760		3,940
	Heating 47 *1	W	3,010		3,090
	Heating 17 *2	W	3,440		3,540
EER2	Cooling		9.40		8.70
SEER2	Cooling		19.20		16.00
HSPF2	Heating		9.80		9.50
COP2	Heating		3.50		3.26
External finish			Munsell 3.0Y 7.8/1.1		
Power supply		V, phase, Hz	208/230, 1, 60		
Max. fuse size (time delay)		A	25		
Min. circuit ampacity		A	23.1		
Fan motor		F.L.A	2.43		
Compressor	Model		SNB220FCGMC		
	Winding resistance (at 68 °F)	Ω	U-V 0.95 V-W 0.95 W-U 0.95		
		R.L.A	12		
		L.R.A	13.7		
Refrigerant control			LEV		
Sound level		dB(A)	54/56		
Defrost method			Reverse cycle		
Dimensions	W	in.	37-13/32		
	D	in.	13		
	H	in.	31-11/32		
Weight		lb.	143		
Remote controller			Wireless type		
Control voltage (by built-in transformer)			12-24 V DC		
Refrigerant piping			Not supplied (optional parts)		
Valve size	Liquid	in.	1/4		
	Gas	in.	A:1/2 B,C,D:3/8		
Connection method	Indoor		Flared		
	Outdoor		Flared		
Refrigerant charge (R410A)		lb.	6lb. 13oz.		
Refrigeration oil (Model)		fl oz. (L)	23.7 (0.7) (FV50S/FW68S)		

NOTE: Test conditions are based on ARI 210/240.

Unit: °F

Mode	Test	Indoor air condition		Outdoor air condition	
		Dry bulb	Wet bulb	Dry bulb	Wet bulb
Cooling	*1: "A" Cooling steady state at rated compressor speed	80	67	95	(75)
	"B-2" Cooling steady state at rated compressor speed	80	67	82	(65)
	"B-1" Cooling steady state at minimum compressor speed	80	67	82	(65)
	Low ambient cooling steady state at minimum compressor speed	80	67	67	(53.5)
	Intermediate cooling steady state at intermediate compressor speed	80	67	87	(69)
Heating	*1: Standard rating-heating at rated compressor speed	70	60	47	43
	*2: Low temperature heating at maximum compressor speed	70	60	17	15
	Maximum temperature heating at minimum compressor speed	70	60	62	56.5
	High temperature heating at minimum compressor speed	70	60	47	43
	Frost accumulation at rated compressor speed	70	60	35	33
	Frost accumulation at intermediate compressor speed	70	60	35	33

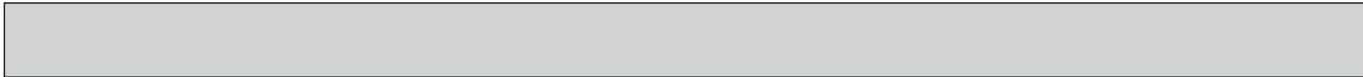

Item		Outdoor model		MXZ-5C42NA MXZ-5C42NA2 MXZ-5C42NA3	
		Indoor type		Non-Duct (06+09+09+09+09)	Duct (09+09+09+09+09)
Capacity	Cooling *1	Btu/h	40,500	NA, NA2: 37,500 / NA3: 37,400	
	Heating 47 *1	Btu/h	45,000	41,000	
	Heating 17 *2	Btu/h	30,500	29,100	
Power consumption	Cooling *1	W	4,403	4,112	
	Heating 47 *1	W	3,575	3,463	
	Heating 17 *2	W	4,750	5,231	
EER	Cooling		9.2	9.0	
SEER	Cooling		19.7	15.2	
HSPF IV(V)	Heating		10.3 (7.7)	9.1 (7.7)	
COP	Heating		3.69	3.47	
External finish		Munsell 3.0Y 7.8/1.1			
Power supply		V, phase, Hz	208/230, 1, 60		
Max. fuse size (time delay)		A	40		
Min. circuit ampacity		A	NA: 31.9 / NA2, NA3: 32.5		
Fan motor		F.L.A	NA: 1.9 / NA2, NA3: 2.43		
Compressor	Model		MNB33FBTMC-L		
	Winding resistance (at 68 °F)	Ω	U-V 0.30 V-W 0.30 W-U 0.30		
		R.L.A	20		
		L.R.A	28.8		
Refrigerant control			LEV		
Sound level		dB(A)	56/58		
Defrost method			Reverse cycle		
Dimensions	W	in.	37-13/32		
	D	in.	13		
	H	in.	41-11/32		
Weight		lb.	189		
Remote controller			Wireless type		
Control voltage (by built-in transformer)			12-24 V DC		
Refrigerant piping			Not supplied (optional parts)		
Valve size	Liquid	in.	1/4		
	Gas	in.	A:1/2 B,C,D,E: 3/8		
Connection method	Indoor		Flared		
	Outdoor		Flared		
Refrigerant charge (R410A)		lb.	8 lb. 13 oz.		
Refrigeration oil (Model)		fl oz. (L)	37.2 (1.1) NA, NA2: (FV50S) / NA3: (FV50S/FVC68D)		

NOTE: Test conditions are based on ARI 210/240.

Unit: °F

Mode	Test	Indoor air condition		Outdoor air condition	
		Dry bulb	Wet bulb	Dry bulb	Wet bulb
Cooling	*1: "A" Cooling steady state at rated compressor speed	80	67	95	(75)
	"B-2" Cooling steady state at rated compressor speed	80	67	82	(65)
	"B-1" Cooling steady state at minimum compressor speed	80	67	82	(65)
	Low ambient cooling steady state at minimum compressor speed	80	67	67	(53.5)
	Intermediate cooling steady state at intermediate compressor speed	80	67	87	(69)
Heating	*1: Standard rating-heating at rated compressor speed	70	60	47	43
	*2: Low temperature heating at maximum compressor speed	70	60	17	15
	Maximum temperature heating at minimum compressor speed	70	60	62	56.5
	High temperature heating at minimum compressor speed	70	60	47	43
	Frost accumulation at rated compressor speed	70	60	35	33
	Frost accumulation at intermediate compressor speed	70	60	35	33

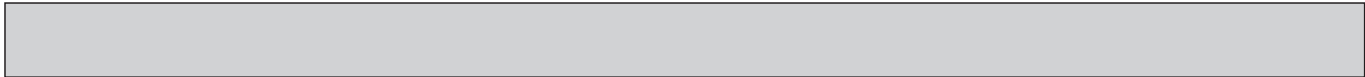

Item		Outdoor model		MXZ-5C42NA4	
		Indoor type		Non-Duct (06+09+09+09+09)	Duct (09+09+09+09+09)
Capacity	Cooling *1	Btu/h	40,500	37,400	
	Heating 47 *1	Btu/h	45,000	41,000	
	Heating 17 *2	Btu/h	30,500	29,100	
Power consumption	Cooling *1	W	4,403	4,112	
	Heating 47 *1	W	3,575	3,463	
	Heating 17 *2	W	4,750	5,231	
EER2	Cooling		9.2	9.0	
SEER2	Cooling		19.7	15.2	
HSPF2	Heating		9.2	9.0	
COP2	Heating		3.68	3.46	
External finish		Munsell 3.0Y 7.8/1.1			
Power supply		V, phase, Hz	208/230, 1, 60		
Max. fuse size (time delay)		A	40		
Min. circuit ampacity		A	32.5		
Fan motor		F.L.A	2.43		
Compressor	Model	MNB33FBTMC-L			
	Winding resistance (at 68 °F)	Ω	U-V 0.30 V-W 0.30 W-U 0.30		
		R.L.A	20		
		L.R.A	28.8		
Refrigerant control			LEV		
Sound level		dB(A)	56/58		
Defrost method			Reverse cycle		
Dimensions	W	in.	37-13/32		
	D	in.	13		
	H	in.	41-11/32		
Weight		lb.	189		
Remote controller			Wireless type		
Control voltage (by built-in transformer)			12-24 V DC		
Refrigerant piping			Not supplied (optional parts)		
Valve size	Liquid	in.	1/4		
	Gas	in.	A:1/2 B,C,D,E: 3/8		
Connection method	Indoor		Flared		
	Outdoor		Flared		
Refrigerant charge (R410A)		lb.	8 lb. 13 oz.		
Refrigeration oil (Model)		fl oz. (L)	37.2 (1.1) (FV50S)		

NOTE: Test conditions are based on ARI 210/240.

Unit: °F

Mode	Test	Indoor air condition		Outdoor air condition	
		Dry bulb	Wet bulb	Dry bulb	Wet bulb
Cooling	*1: "A" Cooling steady state at rated compressor speed	80	67	95	(75)
	"B-2" Cooling steady state at rated compressor speed	80	67	82	(65)
	"B-1" Cooling steady state at minimum compressor speed	80	67	82	(65)
	Low ambient cooling steady state at minimum compressor speed	80	67	67	(53.5)
	Intermediate cooling steady state at intermediate compressor speed	80	67	87	(69)
Heating	*1: Standard rating-heating at rated compressor speed	70	60	47	43
	*2: Low temperature heating at maximum compressor speed	70	60	17	15
	Maximum temperature heating at minimum compressor speed	70	60	62	56.5
	High temperature heating at minimum compressor speed	70	60	47	43
	Frost accumulation at rated compressor speed	70	60	35	33
	Frost accumulation at intermediate compressor speed	70	60	35	33

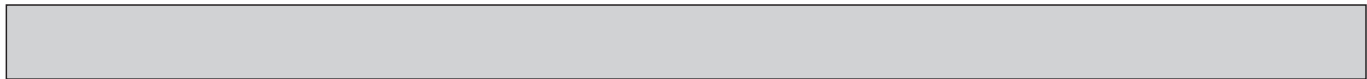

Item		Outdoor model		MXZ-2C20NAHZ MXZ-2C20NAHZ2 MXZ-2C20NAHZ3	
		Indoor type		Non-Duct (09+09)	Duct (09+12)
Capacity	Cooling *1	Btu/h	18,000	20,000	
	Heating 47 *1	Btu/h	22,000	22,000	
	Heating 17 *2	Btu/h	22,000	22,000	
Power consumption	Cooling *1	W	1,334	1,819	
	Heating 47 *1	W	1,612	1,750	
	Heating 17 *2	W	3,071	3,224	
EER	Cooling		13.5	11.0	
SEER	Cooling		17.0	15.0	
HSPF IV(V)	Heating		10.0 (7.8)	9.5 (7.8)	
COP	Heating		4.00	3.69	
External finish		Munsell 3.0Y 7.8/1.1			
Power supply		V, phase, Hz	208/230, 1, 60		
Max. fuse size (time delay)		A	40		
Min. circuit ampacity		A	NA: 28.9 / NA2, NA3: 29.5		
Fan motor		F.L.A	NA: 1.9 / NA2, NA3: 2.43		
Compressor	Model		MNB33FBTMC-L		
	Winding resistance (at 68 °F)	Ω	U-V 0.30 V-W 0.30 W-U 0.30		
		R.L.A	20		
		L.R.A	28.8		
Refrigerant control			LEV		
Sound level		dB(A)	54/58		
Defrost method			Reverse cycle		
Dimensions	W	in.	37-13/32		
	D	in.	13		
	H	in.	41-11/32		
Weight		lb.	187		
Remote controller			Wireless type		
Control voltage (by built-in transformer)			12-24 V DC		
Refrigerant piping			Not supplied (optional parts)		
Valve size	Liquid	in.	1/4		
	Gas	in.	A,B: 3/8		
Connection method	Indoor		Flared		
	Outdoor		Flared		
Refrigerant charge (R410A)		lb.	8 lb. 13 oz.		
Refrigeration oil (Model)		fl oz. (L)	37.2 (1.1) NA, NA2: (FV50S) / NA3: (FV50S/FVC68D)		

NOTE: Test conditions are based on ARI 210/240.

Unit: °F

Mode	Test	Indoor air condition		Outdoor air condition	
		Dry bulb	Wet bulb	Dry bulb	Wet bulb
Cooling	*1: "A" Cooling steady state at rated compressor speed	80	67	95	(75)
	"B-2" Cooling steady state at rated compressor speed	80	67	82	(65)
	"B-1" Cooling steady state at minimum compressor speed	80	67	82	(65)
	Low ambient cooling steady state at minimum compressor speed	80	67	67	(53.5)
	Intermediate cooling steady state at intermediate compressor speed	80	67	87	(69)
Heating	*1: Standard rating-heating at rated compressor speed	70	60	47	43
	*2: Low temperature heating at maximum compressor speed	70	60	17	15
	Maximum temperature heating at minimum compressor speed	70	60	62	56.5
	High temperature heating at minimum compressor speed	70	60	47	43
	Frost accumulation at rated compressor speed	70	60	35	33
	Frost accumulation at intermediate compressor speed	70	60	35	33



Item		Outdoor model	MXZ-2C20NAHZ4		
		Indoor type	Non-Duct (09+09)		Duct (09+12)
Capacity	Cooling *1	Btu/h	18,000		20,000
	Heating 47 *1	Btu/h	22,000		22,000
	Heating 17 *2	Btu/h	22,000		22,000
Power consumption	Cooling *1	W	1,334		1,819
	Heating 47 *1	W	1,612		1,750
	Heating 17 *2	W	3,071		3,224
EER2	Cooling		13.5		11.0
SEER2	Cooling		17.0		16.0
HSPF2	Heating		10.0		8.7
COP2	Heating		4.00		3.68
External finish			Munsell 3.0Y 7.8/1.1		
Power supply		V, phase, Hz	208/230, 1, 60		
Max. fuse size (time delay)		A	40		
Min. circuit ampacity		A	26.9		
Fan motor		F.L.A	2.43		
Compressor	Model		MNB33FBTMC-L		
	Winding resistance (at 68 °F)	Ω	U-V 0.30 V-W 0.30 W-U 0.30		
		R.L.A	17.1		
		L.R.A	28.8		
Refrigerant control			LEV		
Sound level		dB(A)	54/58		
Defrost method			Reverse cycle		
Dimensions	W	in.	37-13/32		
	D	in.	13		
	H	in.	41-11/32		
Weight		lb.	187		
Remote controller			Wireless type		
Control voltage (by built-in transformer)			12-24 V DC		
Refrigerant piping			Not supplied (optional parts)		
Valve size	Liquid	in.	1/4		
	Gas	in.	A,B: 3/8		
Connection method	Indoor		Flared		
	Outdoor		Flared		
Refrigerant charge (R410A)		lb.	8 lb. 13 oz.		
Refrigeration oil (Model)		fl oz. (L)	37.2 (1.1) (FV50S)		

NOTE: Test conditions are based on ARI 210/240.

Unit: °F

Mode	Test	Indoor air condition		Outdoor air condition	
		Dry bulb	Wet bulb	Dry bulb	Wet bulb
Cooling	*1: "A" Cooling steady state at rated compressor speed	80	67	95	(75)
	"B-2" Cooling steady state at rated compressor speed	80	67	82	(65)
	"B-1" Cooling steady state at minimum compressor speed	80	67	82	(65)
	Low ambient cooling steady state at minimum compressor speed	80	67	67	(53.5)
	Intermediate cooling steady state at intermediate compressor speed	80	67	87	(69)
Heating	*1: Standard rating-heating at rated compressor speed	70	60	47	43
	*2: Low temperature heating at maximum compressor speed	70	60	17	15
	Maximum temperature heating at minimum compressor speed	70	60	62	56.5
	High temperature heating at minimum compressor speed	70	60	47	43
	Frost accumulation at rated compressor speed	70	60	35	33
	Frost accumulation at intermediate compressor speed	70	60	35	33

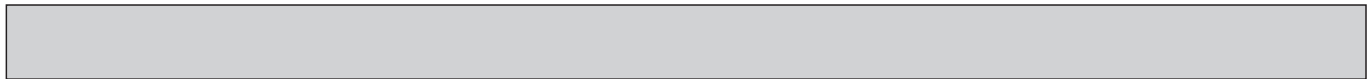

Item		Outdoor model		MXZ-3C24NAHZ MXZ-3C24NAHZ2 MXZ-3C24NAHZ3	
		Indoor type		Non-Duct (06+06+09)	Duct (09+09+09)
Capacity	Cooling *1	Btu/h	22,000	23,600	
	Heating 47 *1	Btu/h	25,000	24,600	
	Heating 17 *2	Btu/h	25,000	24,600	
Power consumption	Cooling *1	W	1,630	2,360	
	Heating 47 *1	W	1,725	1,871	
	Heating 17 *2	W	3,557	3,795	
EER	Cooling		13.5	10.0	
SEER	Cooling		19.0	15.5	
HSPF IV(V)	Heating		10.0 (7.4)	9.0 (7.4)	
COP	Heating		4.25	3.80	
External finish		Munsell 3.0Y 7.8/1.1			
Power supply		V, phase, Hz	208/230, 1, 60		
Max. fuse size (time delay)		A	40		
Min. circuit ampacity		A	NA: 29.9 / NA2, NA3: 30.5		
Fan motor		F.L.A	NA: 1.9 / NA2, NA3: 2.43		
Compressor	Model		MNB33FBTMC-L		
	Winding resistance (at 68 °F)	Ω	U-V 0.30 V-W 0.30 W-U 0.30		
		R.L.A	20		
		L.R.A	28.8		
Refrigerant control			LEV		
Sound level		dB(A)	54/58		
Defrost method			Reverse cycle		
Dimensions	W	in.	37-13/32		
	D	in.	13		
	H	in.	41-11/32		
Weight		lb.	189		
Remote controller			Wireless type		
Control voltage (by built-in transformer)			12-24 V DC		
Refrigerant piping			Not supplied (optional parts)		
Valve size	Liquid	in.	1/4		
	Gas	in.	A: 1/2 B,C: 3/8		
Connection method	Indoor		Flared		
	Outdoor		Flared		
Refrigerant charge (R410A)		lb.	8 lb. 13 oz.		
Refrigeration oil (Model)		fl oz. (L)	37.2 (1.1) NA, NA2: (FV50S) / NA3: (FV50S/FVC68D)		

NOTE: Test conditions are based on ARI 210/240.

Unit: °F

Mode	Test	Indoor air condition		Outdoor air condition	
		Dry bulb	Wet bulb	Dry bulb	Wet bulb
Cooling	*1: "A" Cooling steady state at rated compressor speed	80	67	95	(75)
	"B-2" Cooling steady state at rated compressor speed	80	67	82	(65)
	"B-1" Cooling steady state at minimum compressor speed	80	67	82	(65)
	Low ambient cooling steady state at minimum compressor speed	80	67	67	(53.5)
	Intermediate cooling steady state at intermediate compressor speed	80	67	87	(69)
Heating	*1: Standard rating-heating at rated compressor speed	70	60	47	43
	*2: Low temperature heating at maximum compressor speed	70	60	17	15
	Maximum temperature heating at minimum compressor speed	70	60	62	56.5
	High temperature heating at minimum compressor speed	70	60	47	43
	Frost accumulation at rated compressor speed	70	60	35	33
	Frost accumulation at intermediate compressor speed	70	60	35	33

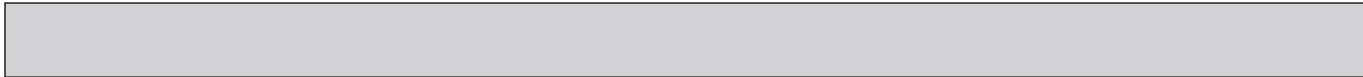

Item		Outdoor model	MXZ-3C24NAHZ4		
		Indoor type	Non-Duct (06+06+09)		Duct (09+09+09)
Capacity	Cooling *1	Btu/h	22,000	23,600	
	Heating 47 *1	Btu/h	25,000	24,600	
	Heating 17 *2	Btu/h	25,000	24,600	
Power consumption	Cooling *1	W	1,630	2,360	
	Heating 47 *1	W	1,725	1,871	
	Heating 17 *2	W	3,557	3,795	
EER2	Cooling		13.5	10.0	
SEER2	Cooling		19.0	15.5	
HSPF2	Heating		10.0	8.5	
COP2	Heating		4.24	3.80	
External finish			Munsell 3.0Y 7.8/1.1		
Power supply		V, phase, Hz	208/230, 1, 60		
Max. fuse size (time delay)		A	40		
Min. circuit ampacity		A	31.5		
Fan motor		F.L.A	2.43		
Compressor	Model		MNB33FBTMC-L		
	Winding resistance (at 68 °F)	Ω	U-V 0.30 V-W 0.30 W-U 0.30		
		R.L.A	19.2		
		L.R.A	28.8		
Refrigerant control			LEV		
Sound level		dB(A)	54/58		
Defrost method			Reverse cycle		
Dimensions	W	in.	37-13/32		
	D	in.	13		
	H	in.	41-11/32		
Weight		lb.	189		
Remote controller			Wireless type		
Control voltage (by built-in transformer)			12-24 V DC		
Refrigerant piping			Not supplied (optional parts)		
Valve size	Liquid	in.	1/4		
	Gas	in.	A: 1/2 B,C: 3/8		
Connection method	Indoor		Flared		
	Outdoor		Flared		
Refrigerant charge (R410A)		lb.	8 lb. 13 oz.		
Refrigeration oil (Model)		fl oz. (L)	37.2 (1.1) (FV50S)		

NOTE: Test conditions are based on ARI 210/240.

Unit: °F

Mode	Test	Indoor air condition		Outdoor air condition	
		Dry bulb	Wet bulb	Dry bulb	Wet bulb
Cooling	*1: "A" Cooling steady state at rated compressor speed	80	67	95	(75)
	"B-2" Cooling steady state at rated compressor speed	80	67	82	(65)
	"B-1" Cooling steady state at minimum compressor speed	80	67	82	(65)
	Low ambient cooling steady state at minimum compressor speed	80	67	67	(53.5)
	Intermediate cooling steady state at intermediate compressor speed	80	67	87	(69)
Heating	*1: Standard rating-heating at rated compressor speed	70	60	47	43
	*2: Low temperature heating at maximum compressor speed	70	60	17	15
	Maximum temperature heating at minimum compressor speed	70	60	62	56.5
	High temperature heating at minimum compressor speed	70	60	47	43
	Frost accumulation at rated compressor speed	70	60	35	33
	Frost accumulation at intermediate compressor speed	70	60	35	33



Item		Outdoor model		MXZ-3C30NAHZ MXZ-3C30NAHZ2 MXZ-3C30NAHZ3	
		Indoor type		Non-Duct (09+09+12)	Duct (09+09+12)
Capacity	Cooling *1	Btu/h	28,400	27,400	
	Heating 47 *1	Btu/h	28,600	27,600	
	Heating 17 *2	Btu/h	28,600	27,600	
Power consumption	Cooling *1	W	2,272	2,661	
	Heating 47 *1	W	2,096	2,187	
	Heating 17 *2	W	4,192	4,258	
EER	Cooling		12.5	10.3	
SEER	Cooling		18.0	16.0	
HSPF IV(V)	Heating		11.0 (8.5)	9.8 (7.7)	
COP	Heating		4.00	3.70	
External finish		Munsell 3.0Y 7.8/1.1			
Power supply		V, phase, Hz	208/230, 1, 60		
Max. fuse size (time delay)		A	40		
Min. circuit ampacity		A	NA: 29.9 / NA2, NA3: 30.5		
Fan motor		F.L.A	NA: 1.9 / NA2, NA3: 2.43		
Compressor	Model		MNB33FBTMC-L		
	Winding resistance (at 68 °F)	Ω	U-V 0.30 V-W 0.30 W-U 0.30		
		R.L.A	20		
		L.R.A	28.8		
Refrigerant control			LEV		
Sound level		dB(A)	54/58		
Defrost method			Reverse cycle		
Dimensions	W	in.	37-13/32		
	D	in.	13		
	H	in.	41-11/32		
Weight		lb.	189		
Remote controller			Wireless type		
Control voltage (by built-in transformer)			12-24 V DC		
Refrigerant piping			Not supplied (optional parts)		
Valve size	Liquid	in.	1/4		
	Gas	in.	A: 1/2 B,C: 3/8		
Connection method	Indoor		Flared		
	Outdoor		Flared		
Refrigerant charge (R410A)		lb.	8 lb. 13 oz.		
Refrigeration oil (Model)		fl oz. (L)	37.2 (1.1) NA, NA2: (FV50S) / NA3: (FV50S/FVC68D)		

NOTE: Test conditions are based on ARI 210/240.

Unit: °F

Mode	Test	Indoor air condition		Outdoor air condition	
		Dry bulb	Wet bulb	Dry bulb	Wet bulb
Cooling	*1: "A" Cooling steady state at rated compressor speed	80	67	95	(75)
	"B-2" Cooling steady state at rated compressor speed	80	67	82	(65)
	"B-1" Cooling steady state at minimum compressor speed	80	67	82	(65)
	Low ambient cooling steady state at minimum compressor speed	80	67	67	(53.5)
	Intermediate cooling steady state at intermediate compressor speed	80	67	87	(69)
Heating	*1: Standard rating-heating at rated compressor speed	70	60	47	43
	*2: Low temperature heating at maximum compressor speed	70	60	17	15
	Maximum temperature heating at minimum compressor speed	70	60	62	56.5
	High temperature heating at minimum compressor speed	70	60	47	43
	Frost accumulation at rated compressor speed	70	60	35	33
	Frost accumulation at intermediate compressor speed	70	60	35	33

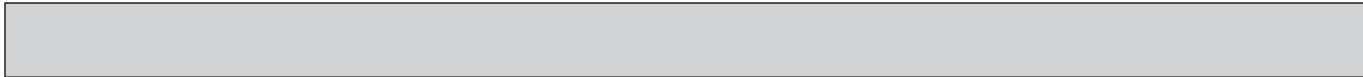

Item		Outdoor model		MXZ-3C30NAHZ4	
		Indoor type		Non-Duct (09+09+12)	Duct (09+09+12)
Capacity	Cooling *1	Btu/h	28,400	27,400	
	Heating 47 *1	Btu/h	28,600	27,600	
	Heating 17 *2	Btu/h	28,600	27,600	
Power consumption	Cooling *1	W	2,272	2,661	
	Heating 47 *1	W	2,096	2,187	
	Heating 17 *2	W	4,192	4,258	
EER2	Cooling		12.5	10.3	
SEER2	Cooling		18.0	16.0	
HSPF2	Heating		10.0	8.50	
COP2	Heating		4.00	3.70	
External finish		Munsell 3.0Y 7.8/1.1			
Power supply		V, phase, Hz	208/230, 1, 60		
Max. fuse size (time delay)		A	40		
Min. circuit ampacity		A	31.5		
Fan motor		F.L.A	2.43		
Compressor	Model	MNB33FBTMC-L			
	Winding resistance (at 68 °F)	Ω	U-V 0.30 V-W 0.30 W-U 0.30		
		R.L.A	19.2		
		L.R.A	28.8		
Refrigerant control		LEV			
Sound level		dB(A)	54/58		
Defrost method		Reverse cycle			
Dimensions	W	in.	37-13/32		
	D	in.	13		
	H	in.	41-11/32		
Weight		lb.	189		
Remote controller		Wireless type			
Control voltage (by built-in transformer)		12-24 V DC			
Refrigerant piping		Not supplied (optional parts)			
Valve size	Liquid	in.	1/4		
	Gas	in.	A: 1/2 B,C: 3/8		
Connection method	Indoor	Flared			
	Outdoor	Flared			
Refrigerant charge (R410A)		lb.	8 lb. 13 oz.		
Refrigeration oil (Model)		fl oz. (L)	37.2 (1.1) (FV50S)		

NOTE: Test conditions are based on ARI 210/240.

Unit: °F

Mode	Test	Indoor air condition		Outdoor air condition	
		Dry bulb	Wet bulb	Dry bulb	Wet bulb
Cooling	*1: "A" Cooling steady state at rated compressor speed	80	67	95	(75)
	"B-2" Cooling steady state at rated compressor speed	80	67	82	(65)
	"B-1" Cooling steady state at minimum compressor speed	80	67	82	(65)
	Low ambient cooling steady state at minimum compressor speed	80	67	67	(53.5)
	Intermediate cooling steady state at intermediate compressor speed	80	67	87	(69)
Heating	*1: Standard rating-heating at rated compressor speed	70	60	47	43
	*2: Low temperature heating at maximum compressor speed	70	60	17	15
	Maximum temperature heating at minimum compressor speed	70	60	62	56.5
	High temperature heating at minimum compressor speed	70	60	47	43
	Frost accumulation at rated compressor speed	70	60	35	33
	Frost accumulation at intermediate compressor speed	70	60	35	33

5

NOISE CRITERIA CURVES

MXZ-2C20NA2
MXZ-2C20NA3
MXZ-2C20NA4

FAN SPEED	FUNCTION	SPL(dB(A))	LINE
High	Cooling	50	●—●
High	Heating	54	○—○

MXZ-3C24NA
MXZ-3C24NA2
MXZ-3C24NA3

FAN SPEED	FUNCTION	SPL(dB(A))	LINE
High	Cooling	51	●—●
High	Heating	55	○—○

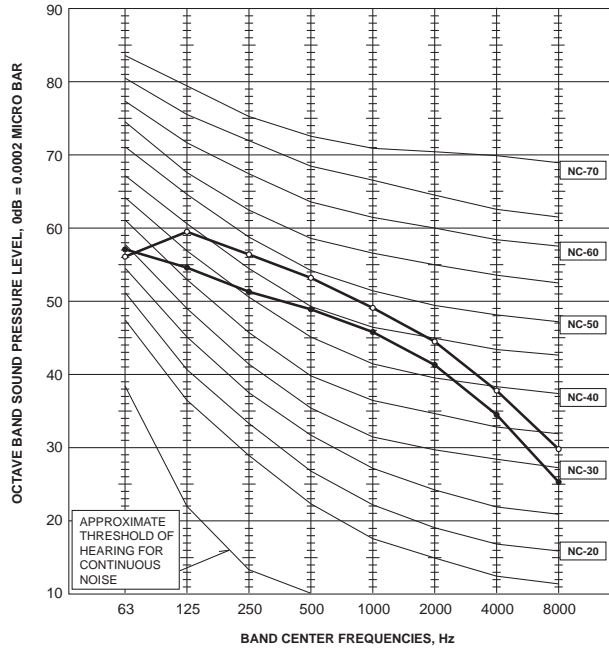
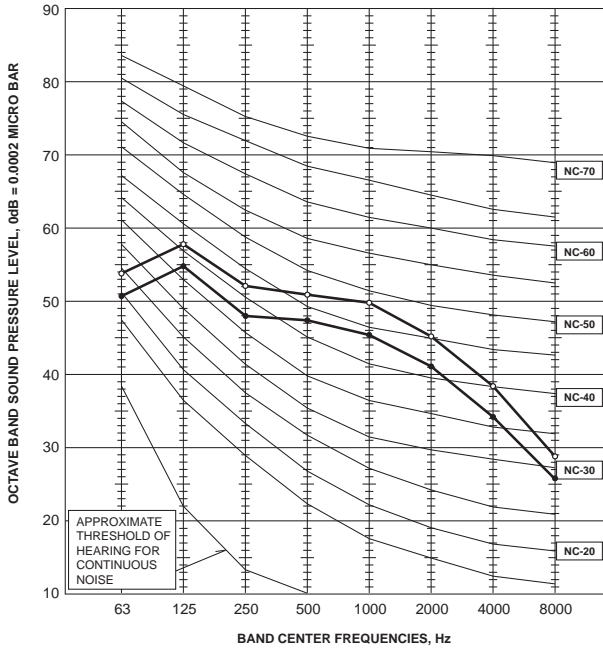

MXZ-3C24NA4

FAN SPEED	FUNCTION	SPL(dB(A))	LINE
High	Cooling	51	●—●
High	Heating	55	○—○

MXZ-3C30NA
MXZ-3C30NA2
MXZ-3C30NA3

FAN SPEED	FUNCTION	SPL(dB(A))	LINE
High	Cooling	52	●—●
High	Heating	56	○—○

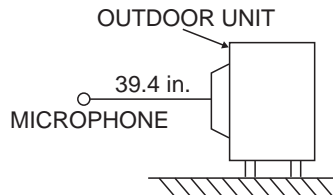
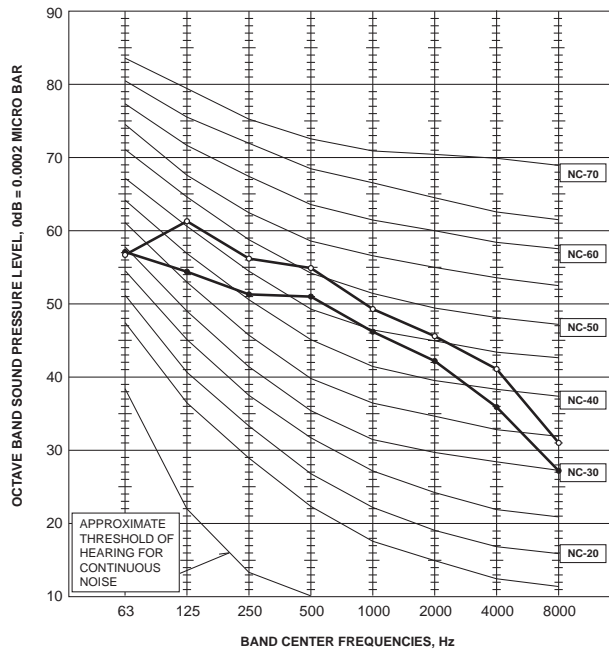
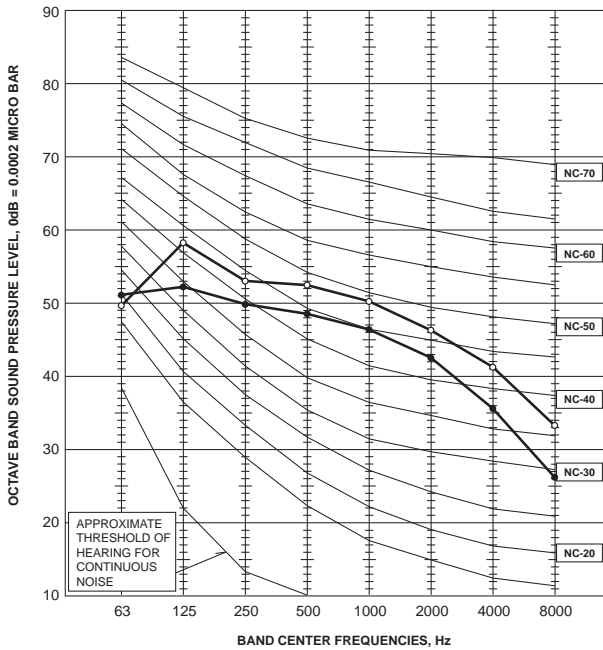

Test conditions

Cooling: Dry-bulb temperature 95°F Wet-bulb temperature 75°F
 Heating: Dry-bulb temperature 45°F Wet-bulb temperature 43°F

MXZ-3C30NA4

FAN SPEED	FUNCTION	SPL(dB(A))	LINE
High	Cooling	52	●—●
High	Heating	56	○—○

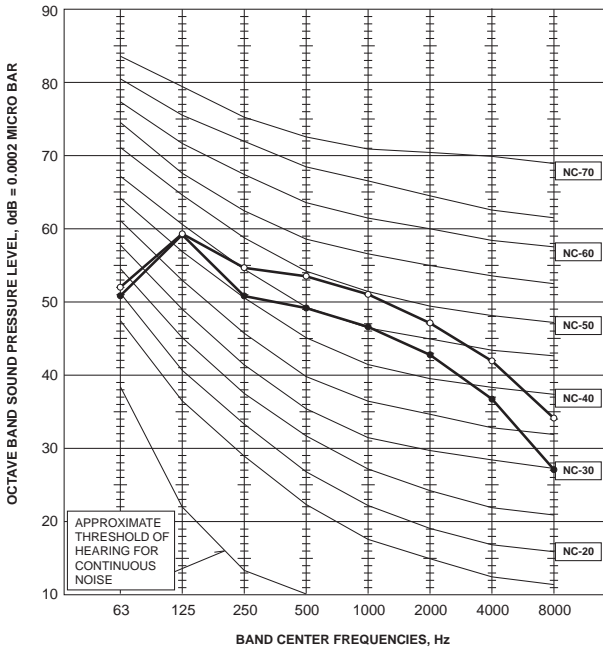

MXZ-4C36NA MXZ-4C36NA2 MXZ-4C36NA3

FAN SPEED	FUNCTION	SPL(dB(A))	LINE
High	Cooling	54	●—●
High	Heating	56	○—○

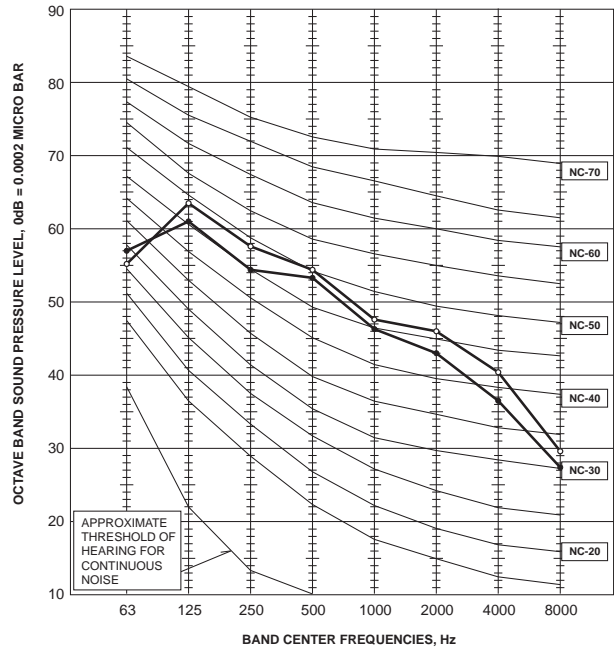

MXZ-4C36NA4

FAN SPEED	FUNCTION	SPL(dB(A))	LINE
High	Cooling	54	●—●
High	Heating	56	○—○

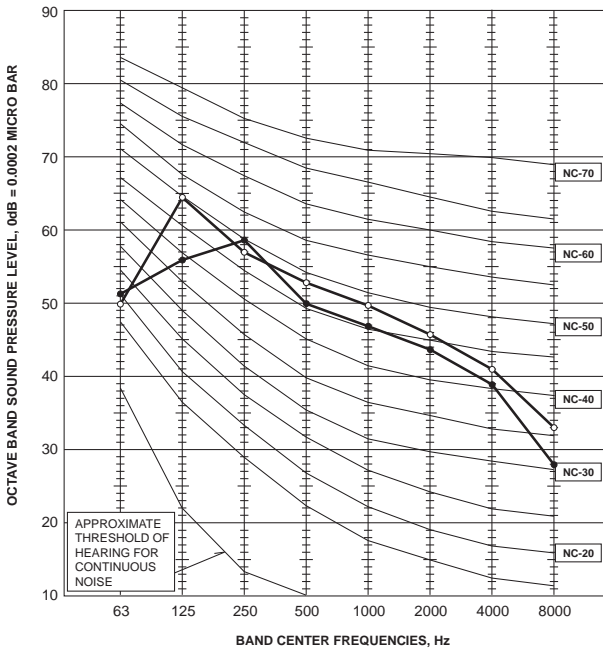

MXZ-5C42NA MXZ-5C42NA2 MXZ-5C42NA3 MXZ-5C42NA4

FAN SPEED	FUNCTION	SPL(dB(A))	LINE
High	Cooling	56	●—●
High	Heating	58	○—○

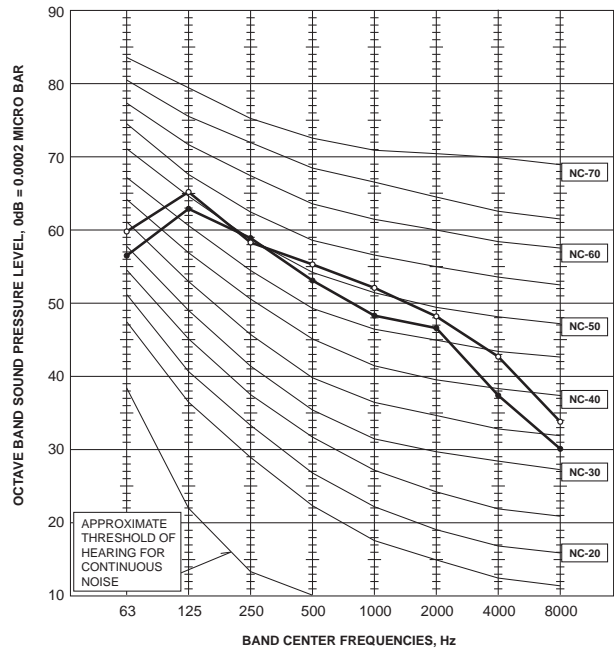

MXZ-2C20NAHZ
MXZ-2C20NAHZ2
MXZ-2C20NAHZ3
MXZ-2C20NAHZ4

FAN SPEED	FUNCTION	SPL(dB(A))	LINE
High	Cooling	54	●—●
High	Heating	58	○—○

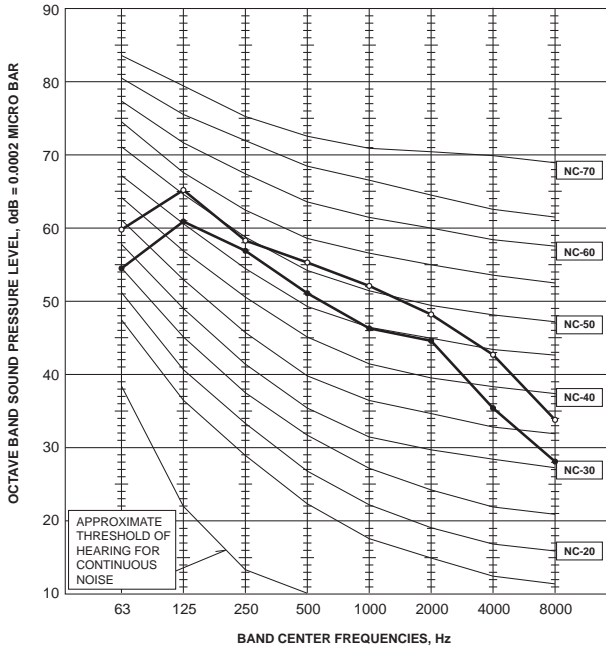

MXZ-3C24NAHZ
MXZ-3C24NAHZ2
MXZ-3C24NAHZ3
MXZ-3C24NAHZ4

FAN SPEED	FUNCTION	SPL(dB(A))	LINE
High	Cooling	54	●—●
High	Heating	58	○—○

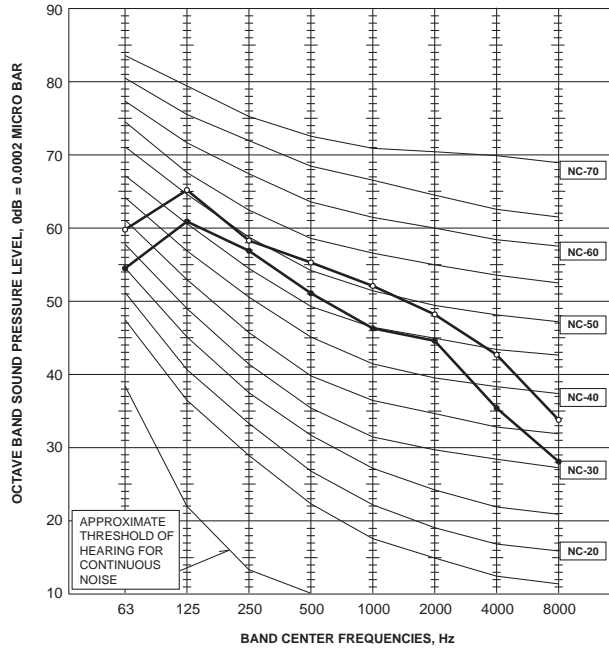

MXZ-3C30NAHZ
MXZ-3C30NAHZ2
MXZ-3C30NAHZ3
MXZ-3C30NAHZ4

FAN SPEED	FUNCTION	SPL(dB(A))	LINE
High	Cooling	54	●—●
High	Heating	58	○—○

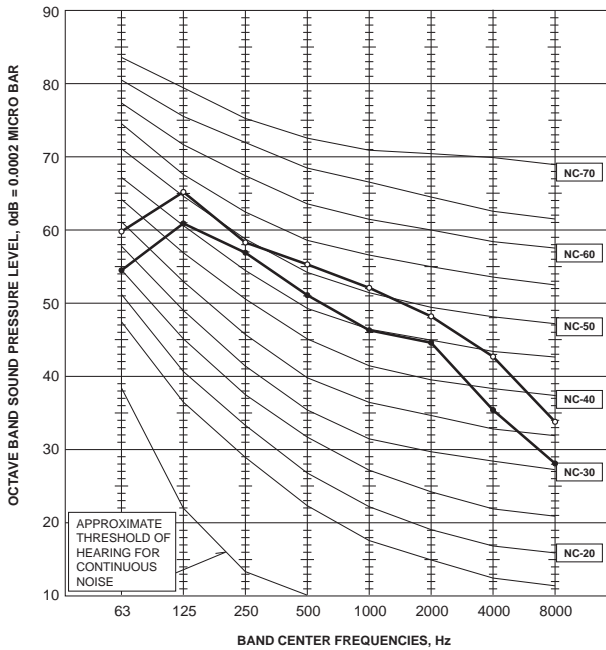

MXZ-2C20NA2 MXZ-2C20NA3 MXZ-2C20NA4

Unit: inch (mm)

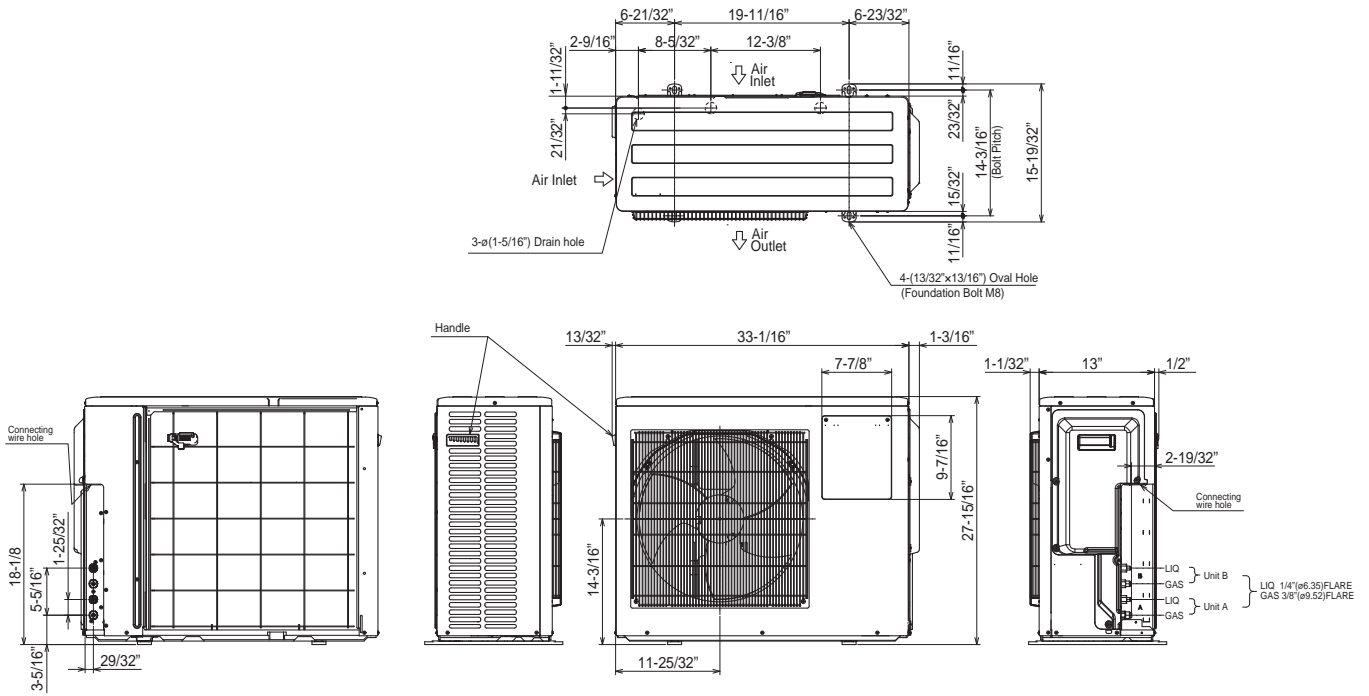

1.FREE SPACE

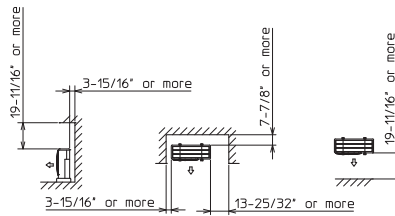

2.SERVICE SPACE

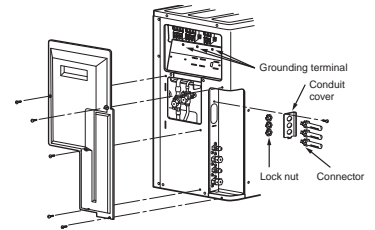
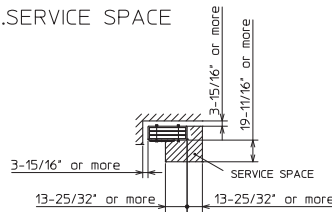

MXZ-3C24NA MXZ-3C24NA2 MXZ-3C24NA3 MXZ-3C24NA4
 MXZ-3C30NA MXZ-3C30NA2 MXZ-3C30NA3 MXZ-3C30NA4

Unit: inch (mm)

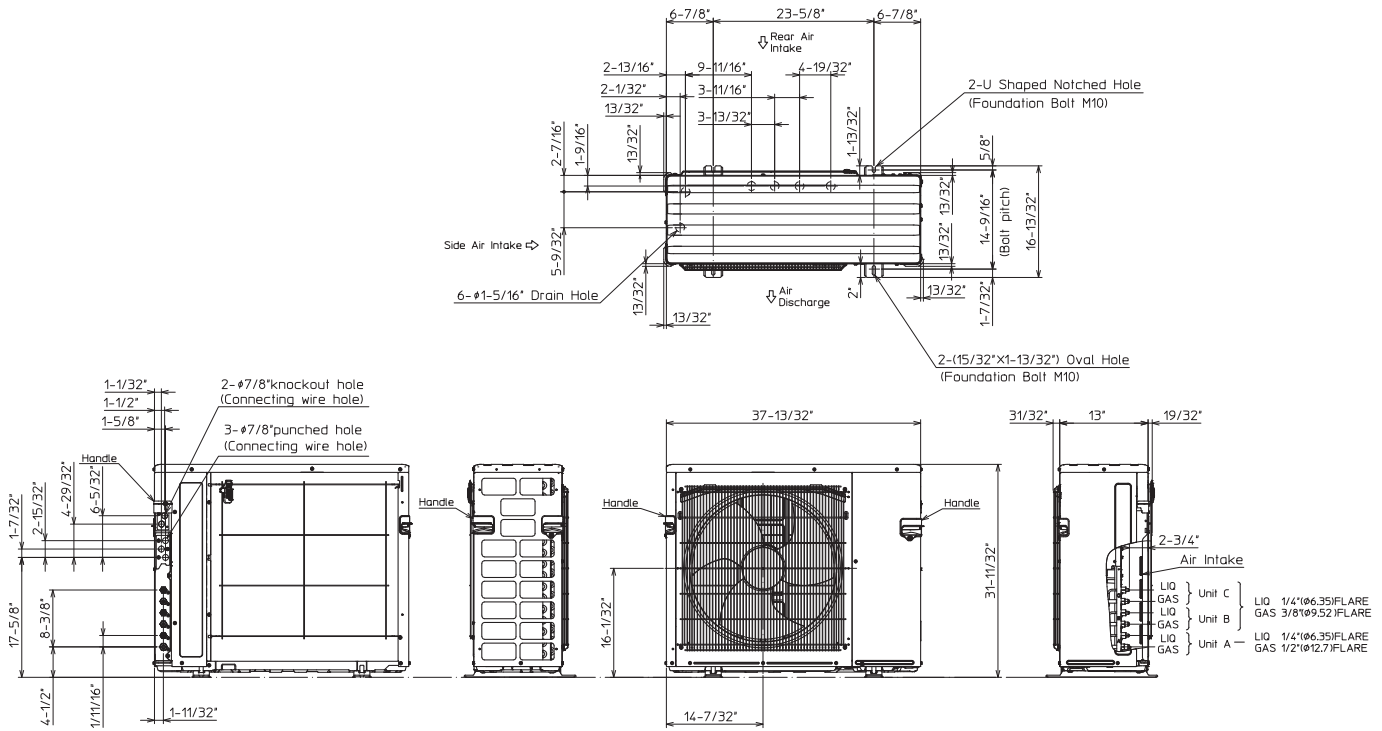

1. FREE SPACE

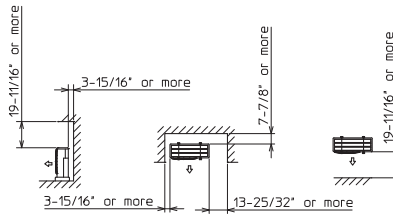

2. SERVICE SPACE

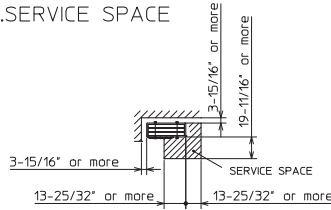

(NA, NA2, NA3)

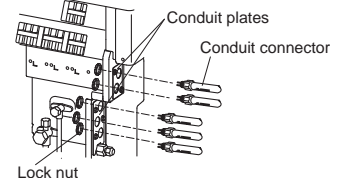

(NA4)

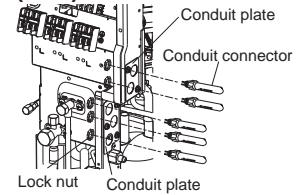

MXZ-4C36NA MXZ-4C36NA2 MXZ-4C36NA3 MXZ-4C36NA4

Unit: inch (mm)

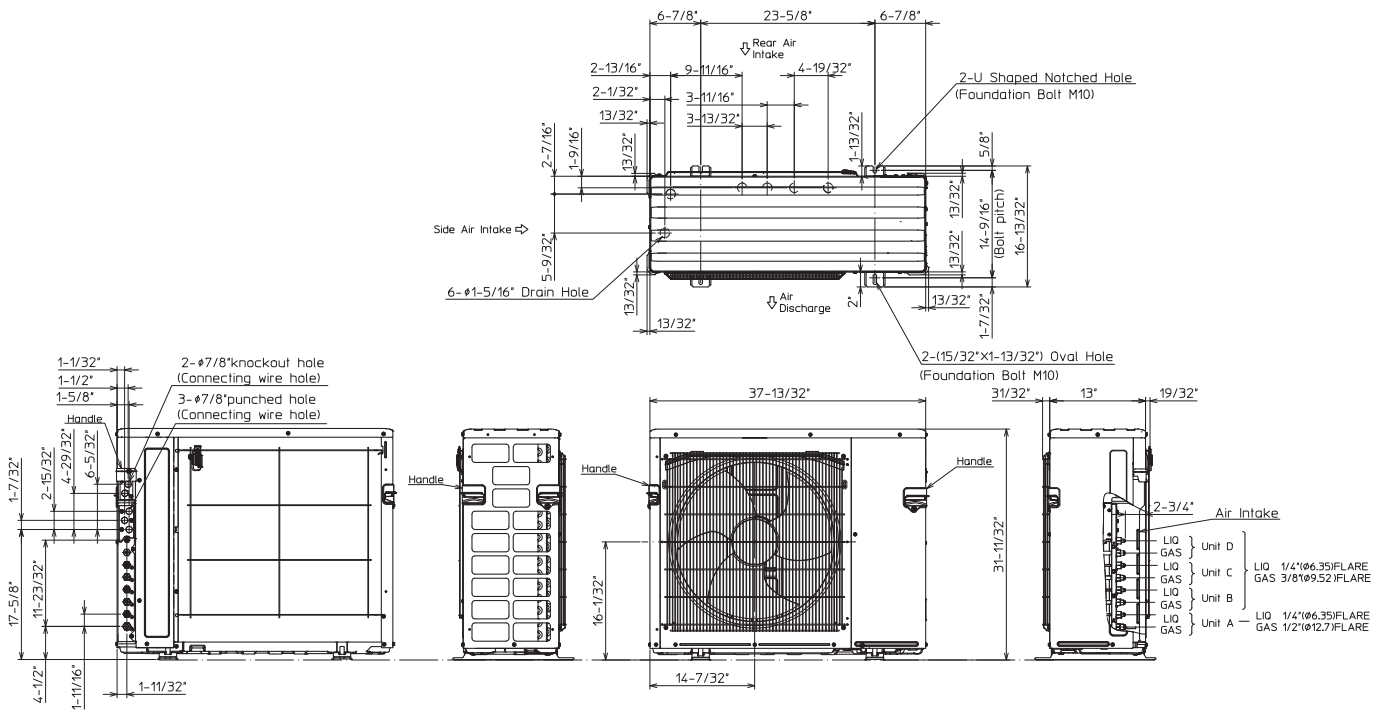

1.FREE SPACE

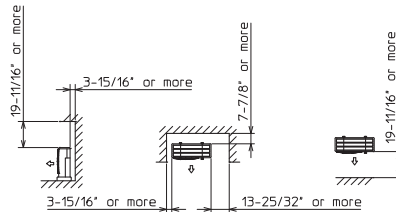

2.SERVICE SPACE

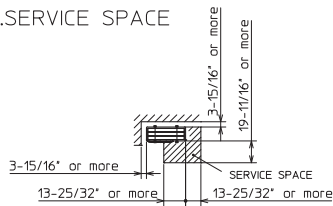

(NA, NA2, NA3)

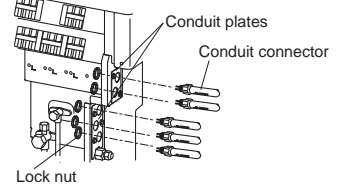

(NA4)

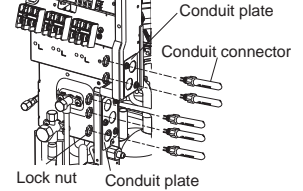

MXZ-5C42NA MXZ-5C42NA2 MXZ-5C42NA3 MXZ-5C42NA4

Unit: inch (mm)

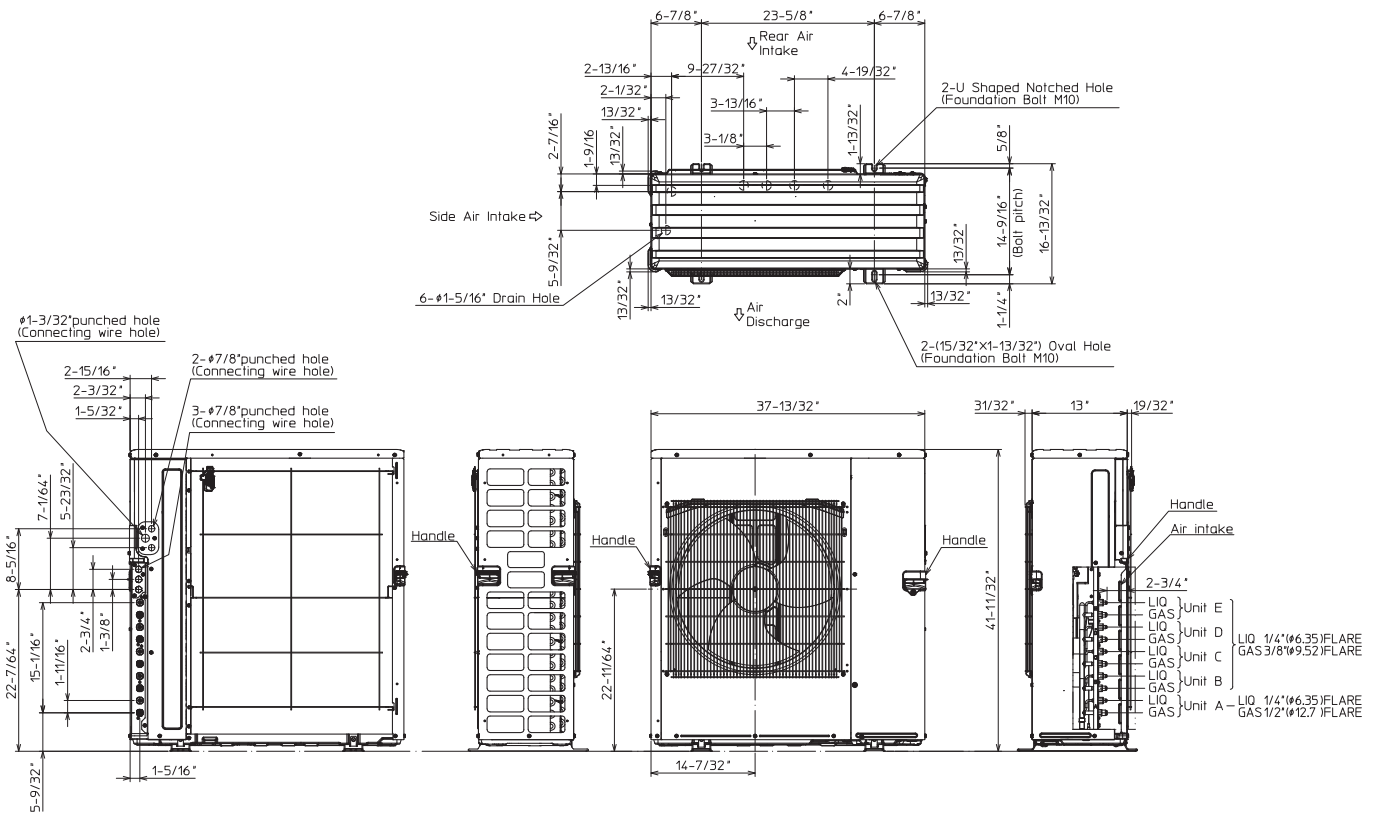

1.FREE SPACE

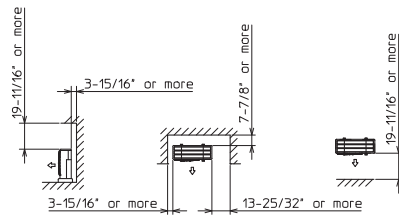

2.SERVICE SPACE

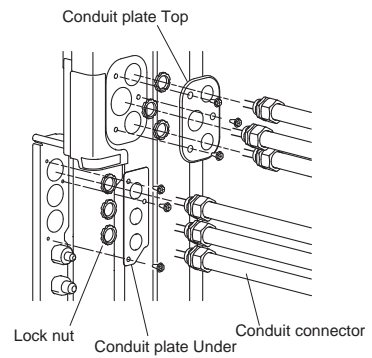
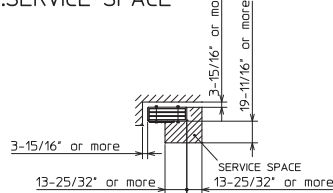

MXZ-2C20NAHZ MXZ-2C20NAHZ2 MXZ-2C20NAHZ3 MXZ-2C20NAHZ4

Unit: inch (mm)

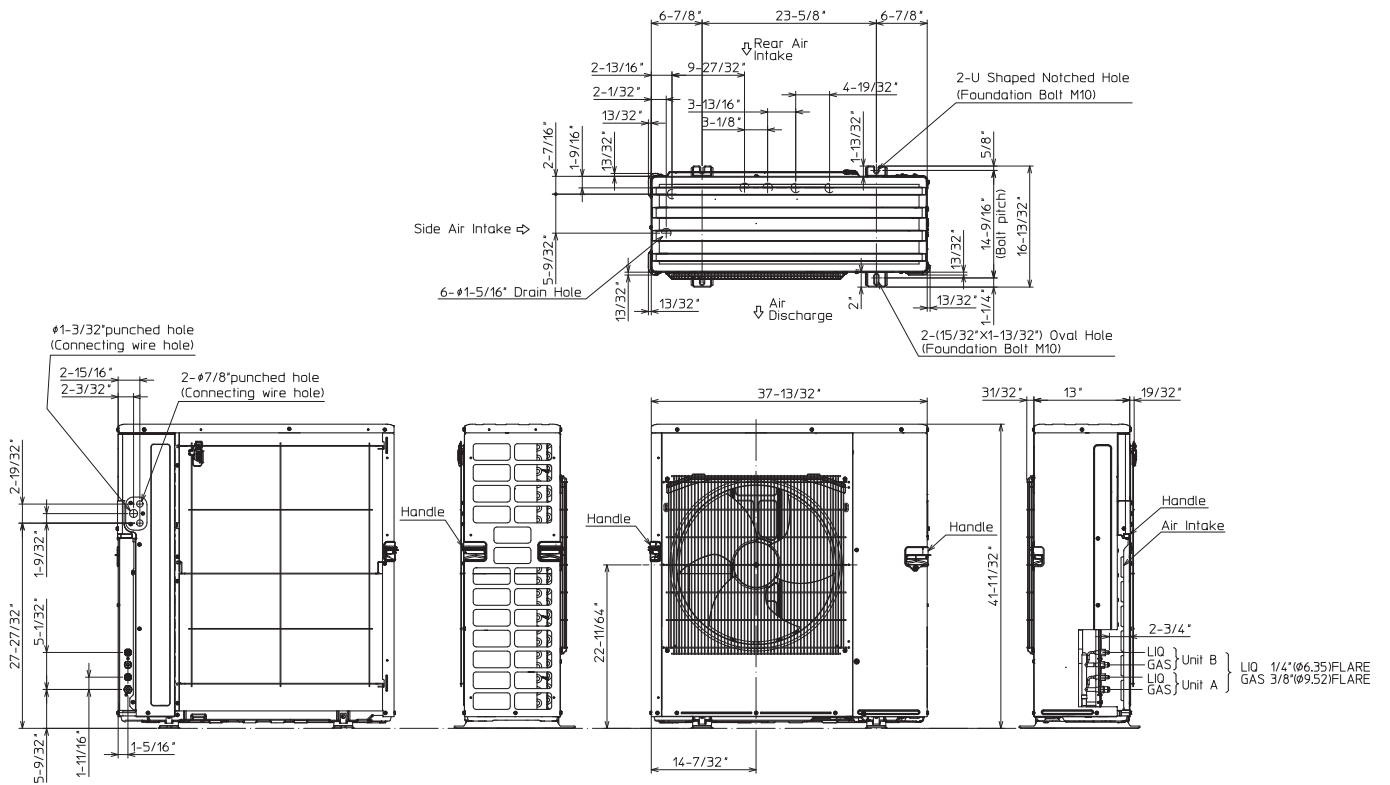

1.FREE SPACE

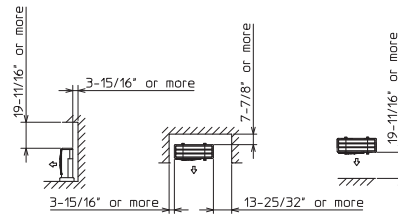

2.SERVICE SPACE

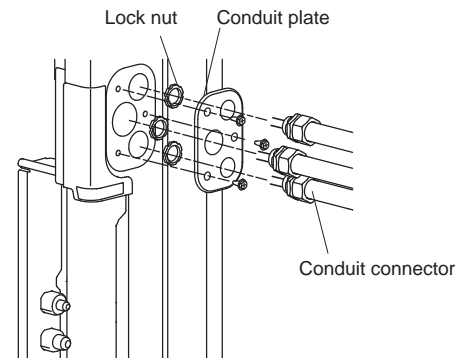
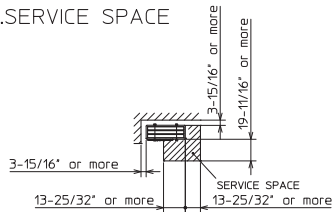

MXZ-3C24NAHZ MXZ-3C24NAHZ2 MXZ-3C24NAHZ3 MXZ-3C24NAHZ4
MXZ-3C30NAHZ MXZ-3C30NAHZ2 MXZ-3C30NAHZ3 MXZ-3C30NAHZ4

Unit: inch (mm)

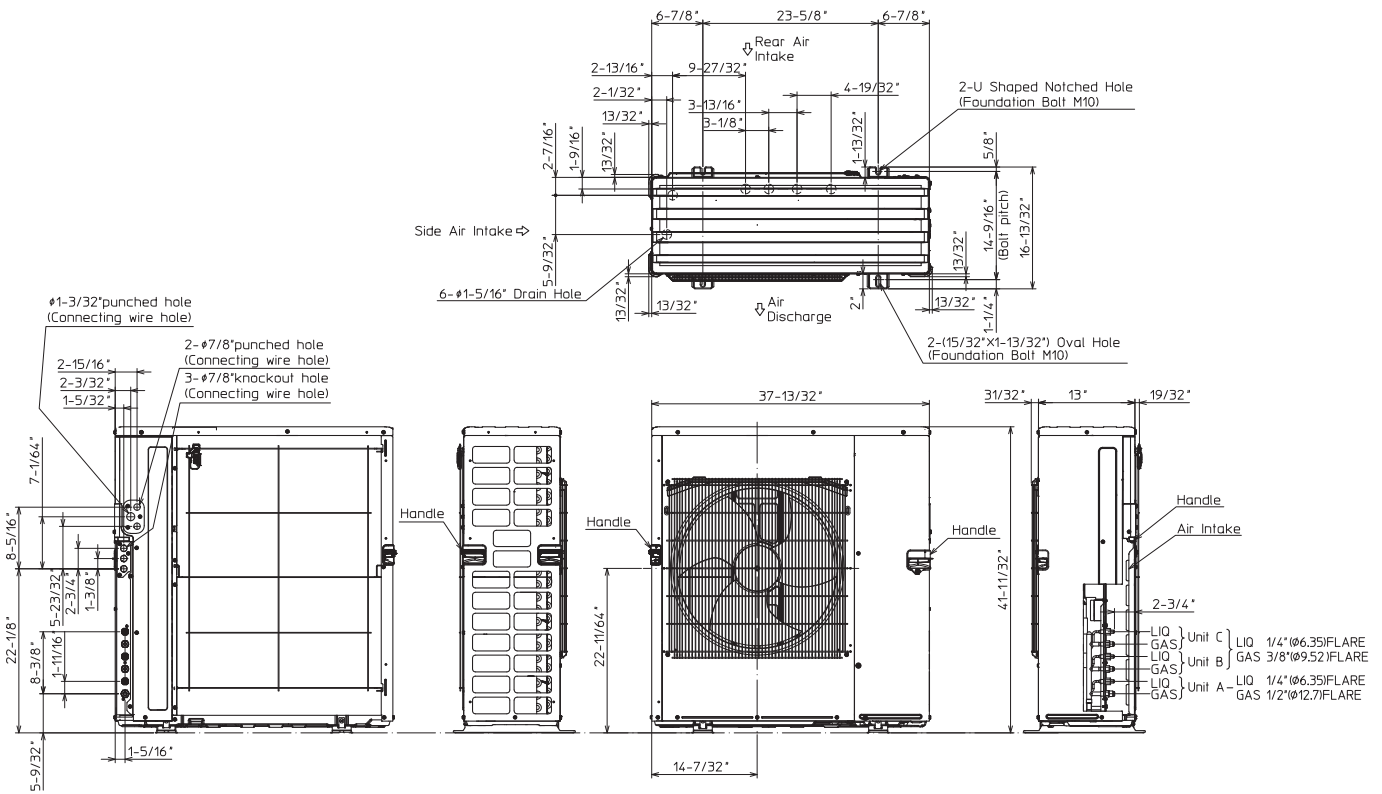

1.FREE SPACE

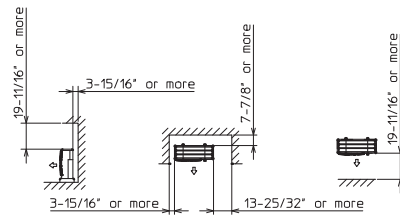

2.SERVICE SPACE

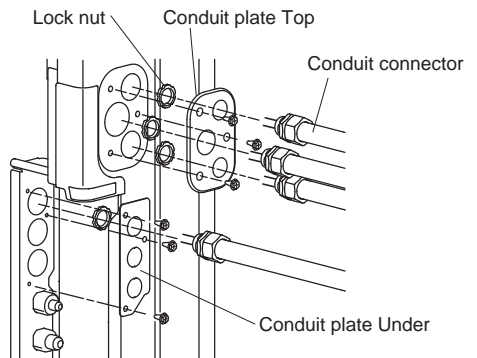
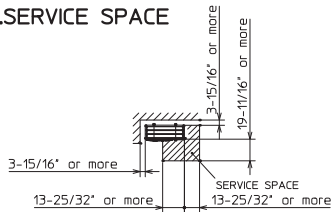

MXZ-2C20NA2

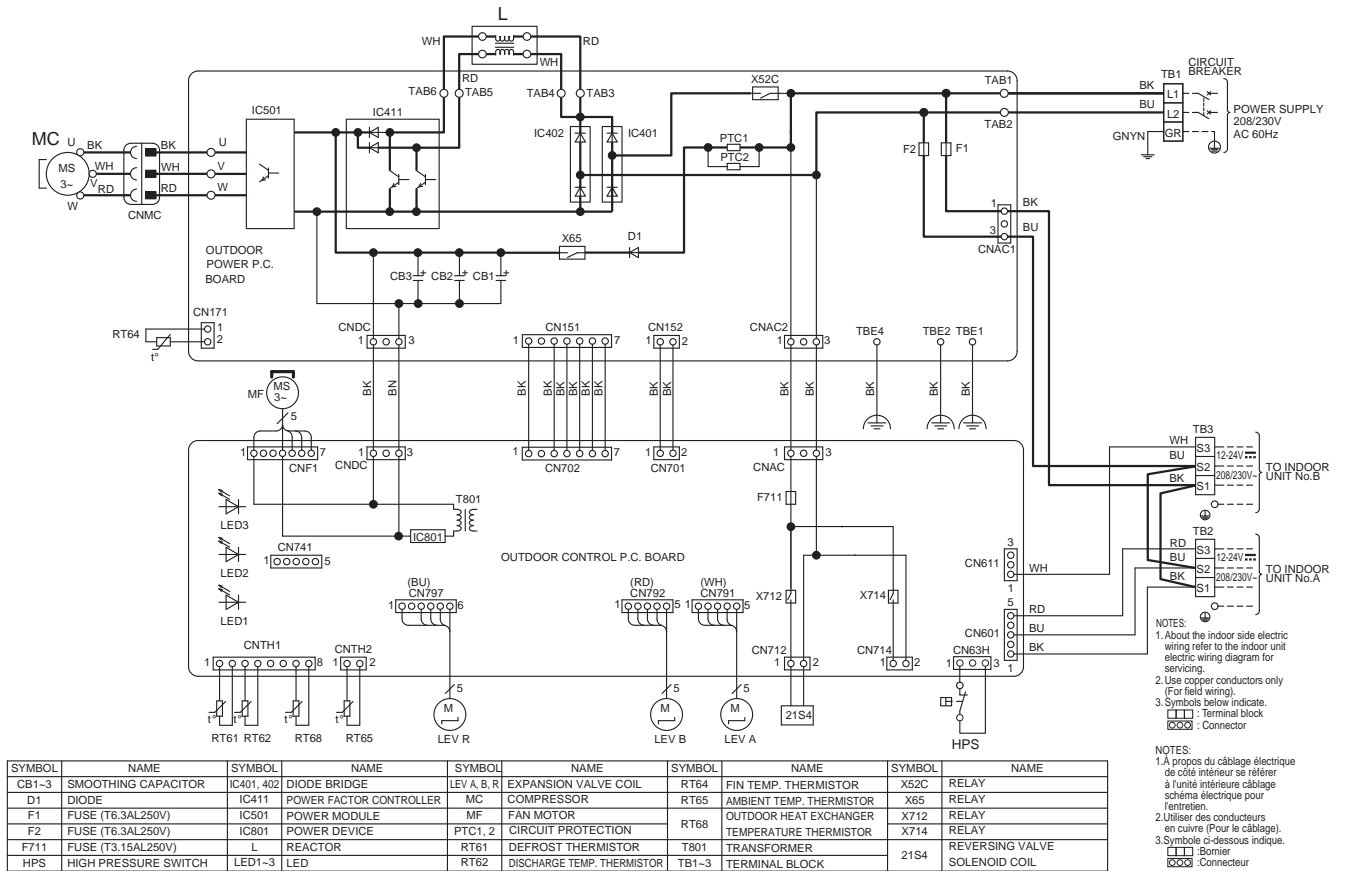

[Connection between reactor and outdoor power P.C. board]

* There are 2 types of reactors, which may have a number display. Even if there is a number display, please wire as shown in the figure below.

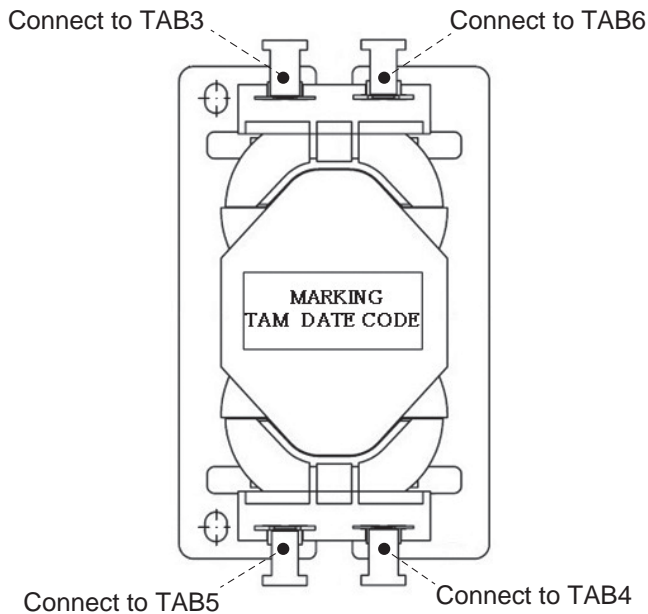

MXZ-2C20NA3

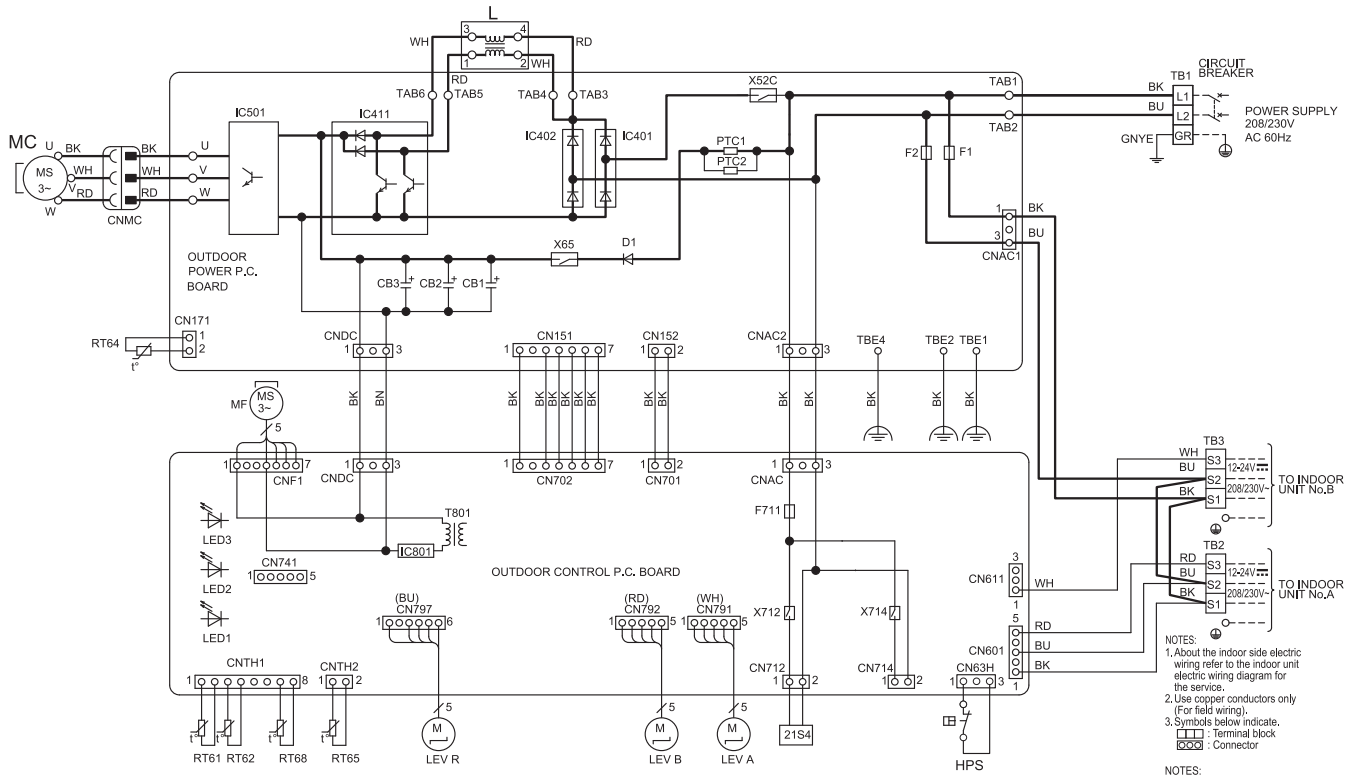

- NOTES:
1. About the indoor side electric wiring refer to the indoor unit electric wiring diagram for the service.
 2. Use copper conductors only (For field wiring).
 3. Symbols below indicate.
 - Terminal block
 - Connector
- NOTES:
1. A propos du câblage électrique de côté intérieur se référer à l'unité intérieure câblage schéma électrique pour l'entretien.
 2. Utiliser des conducteurs en cuivre (Pour le câblage).
 3. Symbole ci-dessous indique.
 - Bornier
 - Connecteur

SYMBOL	NAME	SYMBOL	NAME	SYMBOL	NAME	SYMBOL	NAME	SYMBOL	NAME
CB1-3	SMOOTHING CAPACITOR	IC401, 402	DIODE BRIDGE	LEV A, B, R	EXPANSION VALVE COIL	RT64	FIN TEMP. THERMISTOR	X52C	RELAY
D1	DIODE	IC411	POWER FACTOR CONTROLLER	MC	COMPRESSOR	RT65	AMBIENT TEMP. THERMISTOR	X65	RELAY
F1	FUSE (T6.3AL250V)	IC501	POWER MODULE	MF	FAN MOTOR	RT68	OUTDOOR HEAT EXCHANGER TEMP. THERMISTOR	X712	RELAY
F2	FUSE (T6.3AL250V)	IC801	POWER DEVICE	PTC1, 2	CIRCUIT PROTECTOR	RT68	OUTDOOR HEAT EXCHANGER TEMP. THERMISTOR	X714	RELAY
F711	FUSE (T3.15AL250V)	L	REACTOR	RT61	DEFROST THERMISTOR	T801	TRANSFORMER	21S4	REVERSING VALVE SOLENOID COIL
HPS	HIGH PRESSURE SWITCH	LED1-3	LED	RT62	DISCHARGE TEMP. THERMISTOR	TB1-3	TERMINAL BLOCK		

[If the reactor does not have a number display, refer to the figure below.]

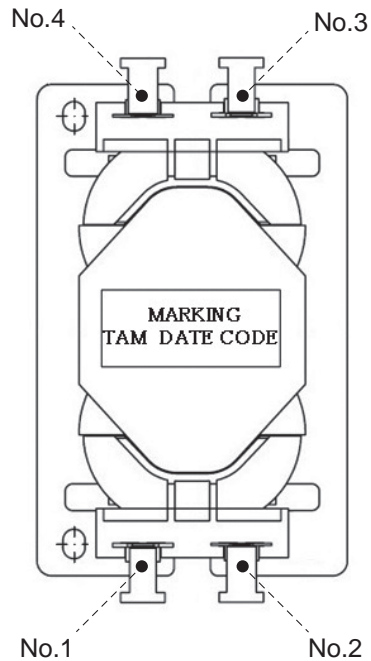

MXZ-2C20NA4

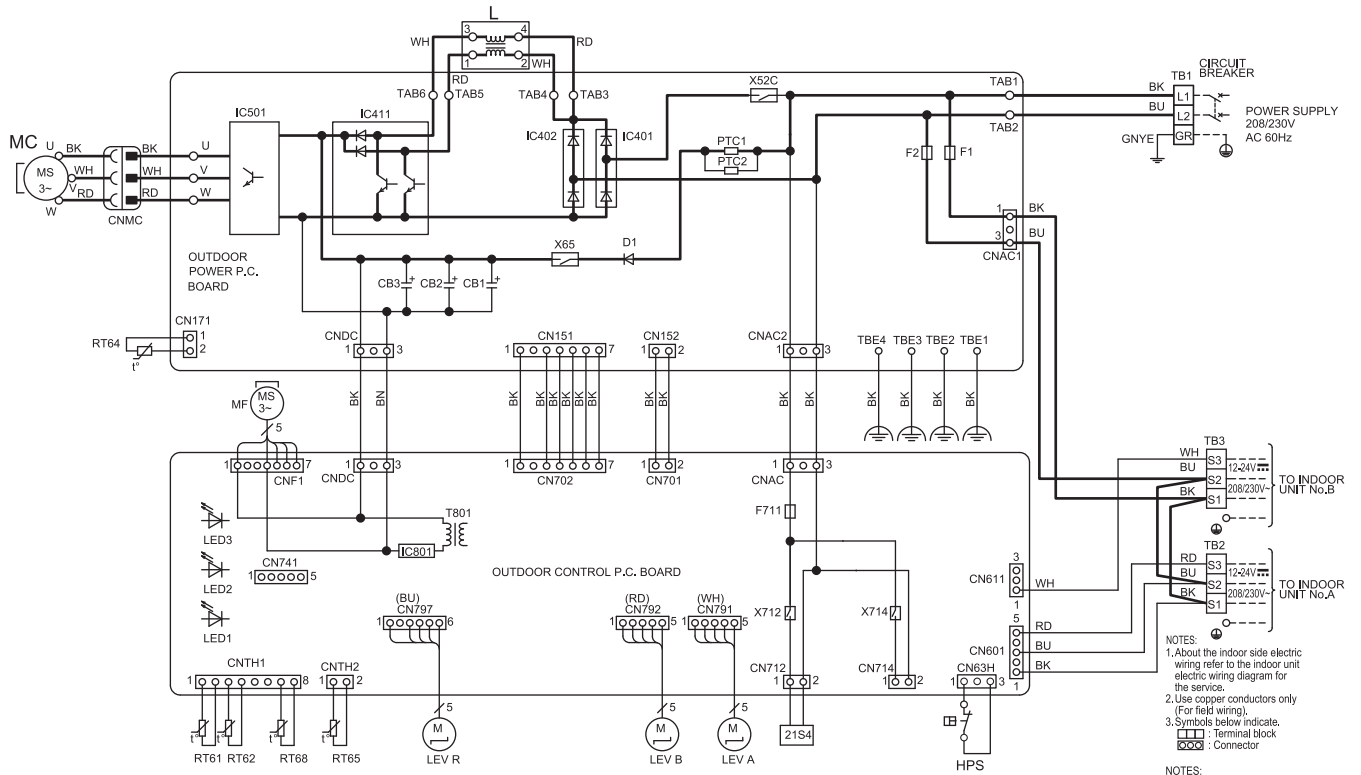

SYMBOL	NAME	SYMBOL	NAME	SYMBOL	NAME	SYMBOL	NAME
CB1-3	SMOOTHING CAPACITOR	IC401, 402	DIODE BRIDGE	LEV A, B, R	EXPANSION VALVE COIL	RT64	FIN TEMP. THERMISTOR
D1	DIODE	IC411	POWER FACTOR CONTROLLER	MC	COMPRESSOR	RT65	AMBIENT TEMP. THERMISTOR
F1	FUSE (T6.3AL250V)	IC501	POWER MODULE	MF	FAN MOTOR	RT68	OUTDOOR HEAT EXCHANGER
F2	FUSE (T6.3AL250V)	IC801	POWER DEVICE	PTC1, 2	CIRCUIT PROTECTOR	X712	TEMP. THERMISTOR
F711	FUSE (T3.15AL250V)	L	REACTOR	RT61	DEFROST THERMISTOR	T801	TRANSFORMER
HPS	HIGH PRESSURE SWITCH	LED1-3	LED	RT62	DISCHARGE TEMP. THERMISTOR	TB1-3	TERMINAL BLOCK

- NOTES:
- About the indoor side electric wiring refer to the indoor unit electric wiring diagram for the service.
 - Use copper conductors only (For field wiring).
 - Symbols below indicate.
 : Terminal block
 : Connector
- NOTES:
- À propos du câblage électrique de côté intérieur se référer à l'unité intérieure câblage schéma électrique pour l'entretien.
 - Utiliser des conducteurs en cuivre (Pour le câblage).
 - Symbole ci-dessous indique.
 : Bornier
 : Connecteur

[If the reactor does not have a number display, refer to the figure below.]

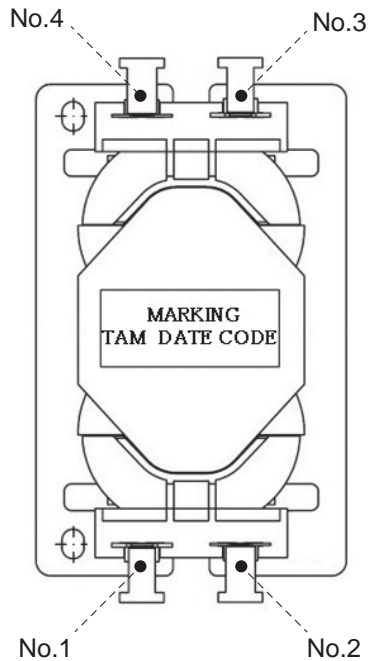

MXZ-3C24NA MXZ-3C30NA

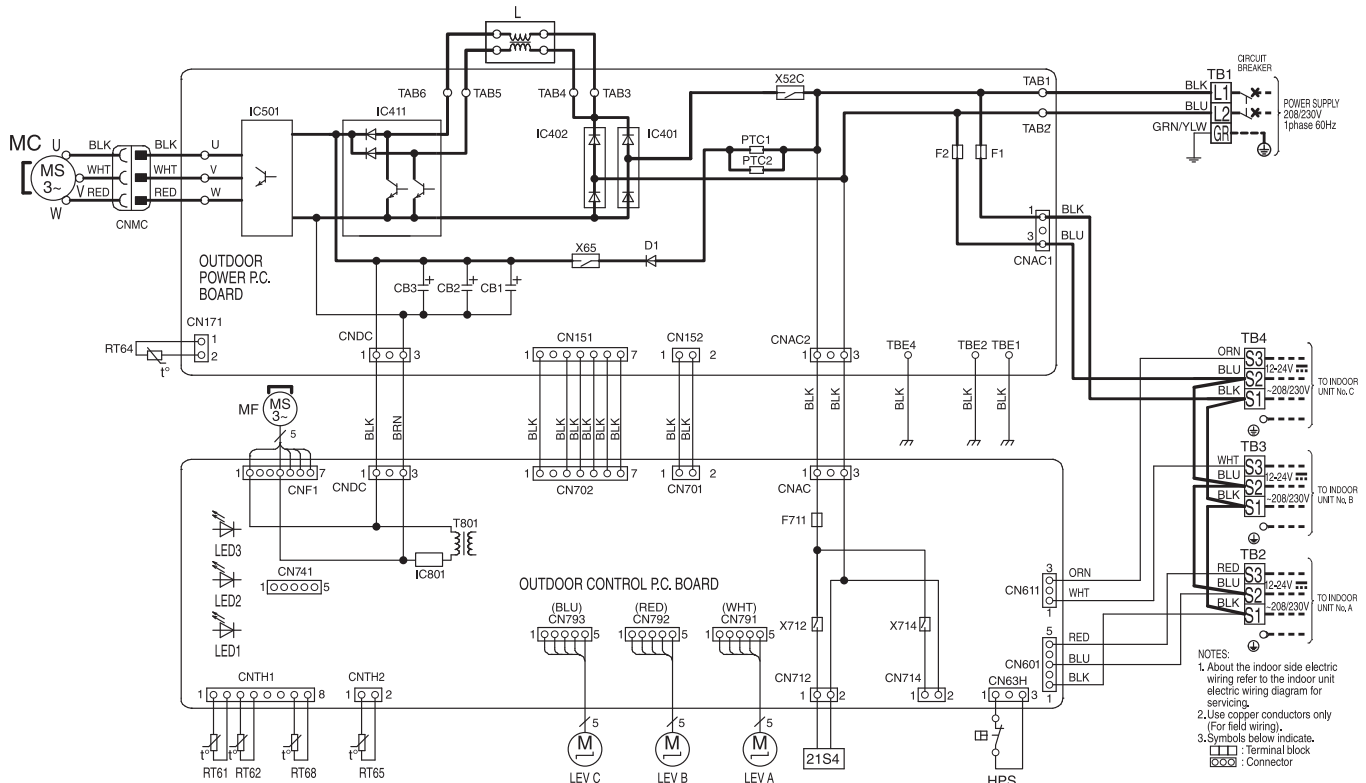

- NOTES:
- About the indoor side electric wiring refer to the indoor unit electric wiring diagram for servicing.
 - Use copper conductors only (For field wiring).
 - Symbols below indicate.
 - Terminal block
 - Bornier
 - Connecteur
- NOTES:
- À propos du câblage électrique de côté intérieur se référer à l'unité intérieure schéma électrique pour l'entretien.
 - Utiliser des conducteurs en cuivre (Pour le câblage).
 - Symbole (=dessous indique).
 - Bornier
 - Connecteur

SYMBOL	NAME	SYMBOL	NAME	SYMBOL	NAME	SYMBOL	NAME	SYMBOL	NAME
CB1-3	SMOOTHING CAPACITOR	IC401_402	DIODE BRIDGE	LEV A-C	EXPANSION VALVE COIL	RT64	FIN TEMP.THERMISTOR	X52C	RELAY
D1	DIODE	IC411	POWER FACTOR CONTROLLER	MC	COMPRESSOR	RT65	AMBIENT TEMP.THERMISTOR	X65	RELAY
F1	FUSE (T6.3AL 250V)	IC501	POWER MODULE	MF	FAN MOTOR	RT68	OUTDOOR HEAT EXCHANGER	X712	RELAY
F2	FUSE (T6.3AL 250V)	IC801	POWER DEVICE	PTC1_2	CIRCUIT PROTECTION		TEMPERATURE THERMISTOR	X714	RELAY
F711	FUSE (T3.15AL 250V)	L	REACTOR	RT61	DEFROST THERMISTOR	T801	TRANSFORMER		REVERSING VALVE SOLENOID COIL
HPS	HIGH PRESSURE SWITCH	LED1-3	LED	RT62	DISCHARGE TEMP.THERMISTOR	TB1-4	TERMINAL BLOCK	21S4	

[Connection between reactor and outdoor power P.C. board]
 * There are 2 types of reactors, which may have a number display.
 Even if there is a number display, please wire as shown in the figure below.

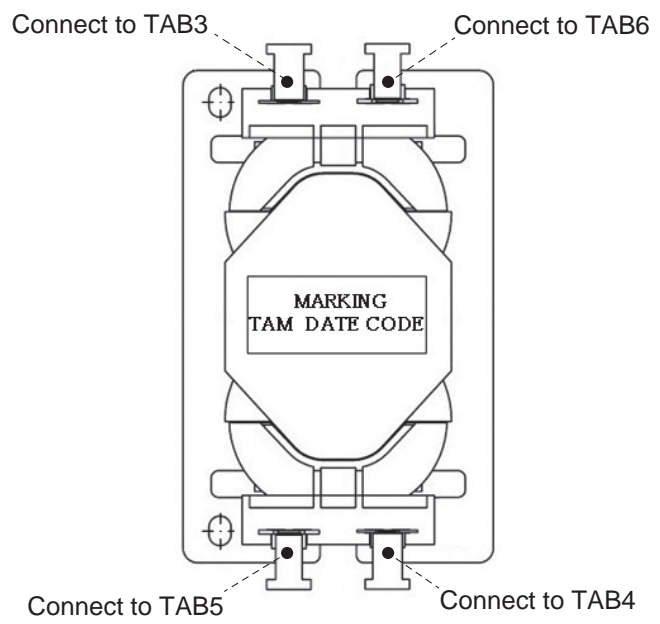

MXZ-3C24NA2 MXZ-3C30NA2

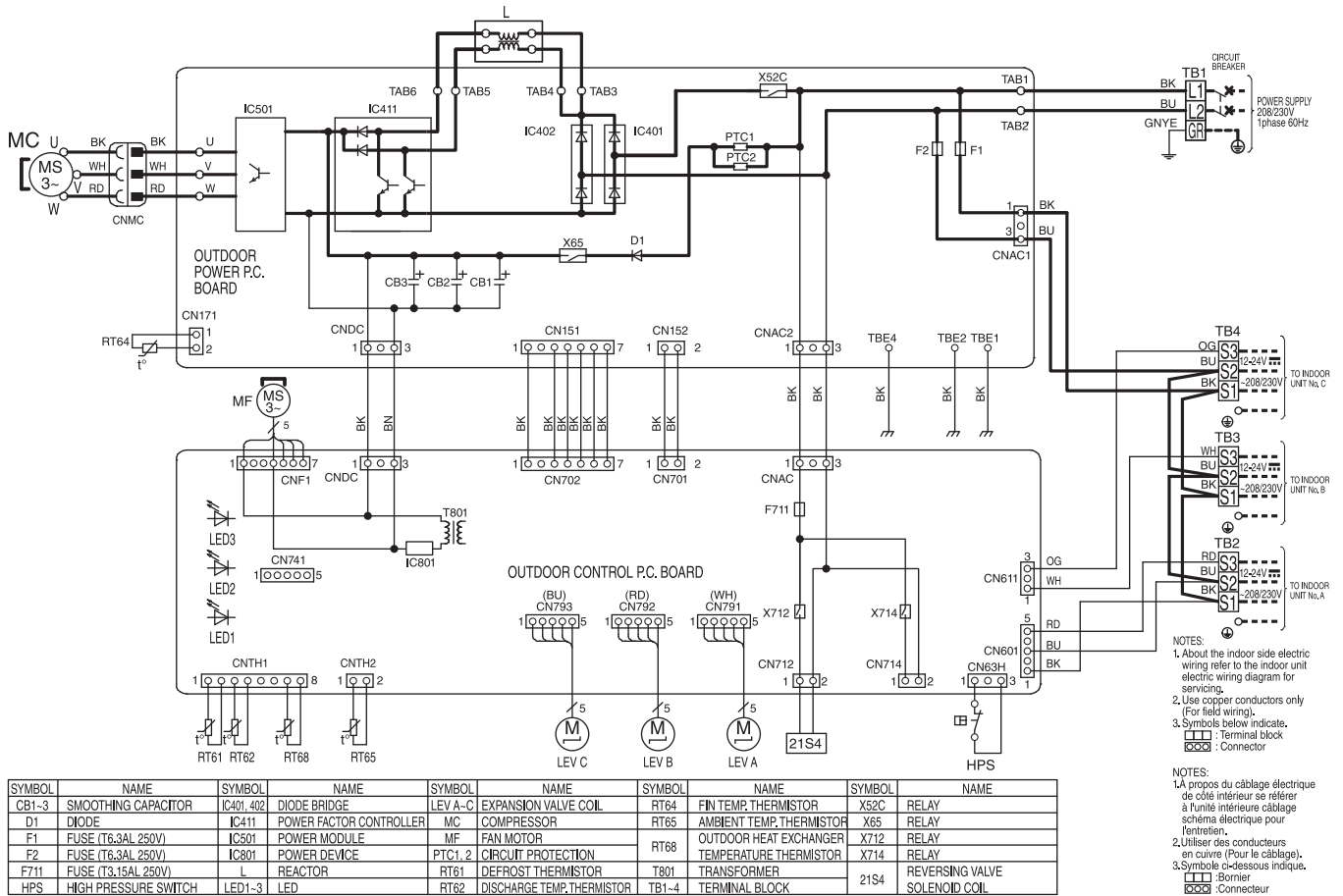

[Connection between reactor and outdoor power P.C. board]

* There are 2 types of reactors, which may have a number display. Even if there is a number display, please wire as shown in the figure below.

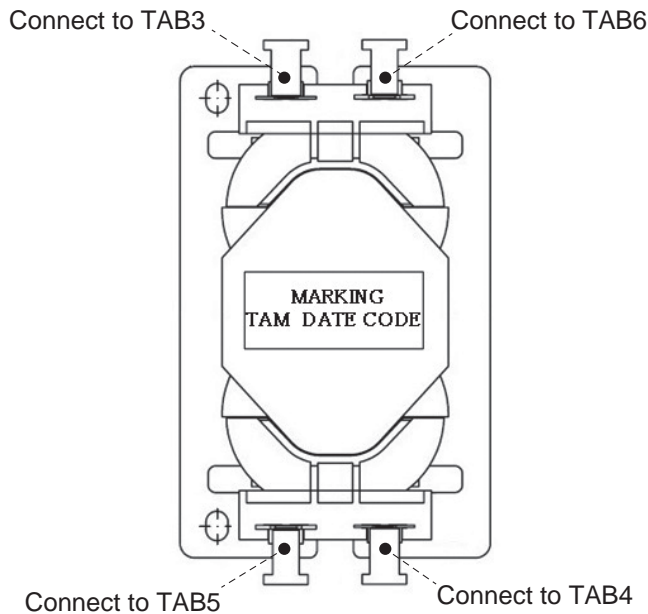

MXZ-3C24NA3 MXZ-3C30NA3

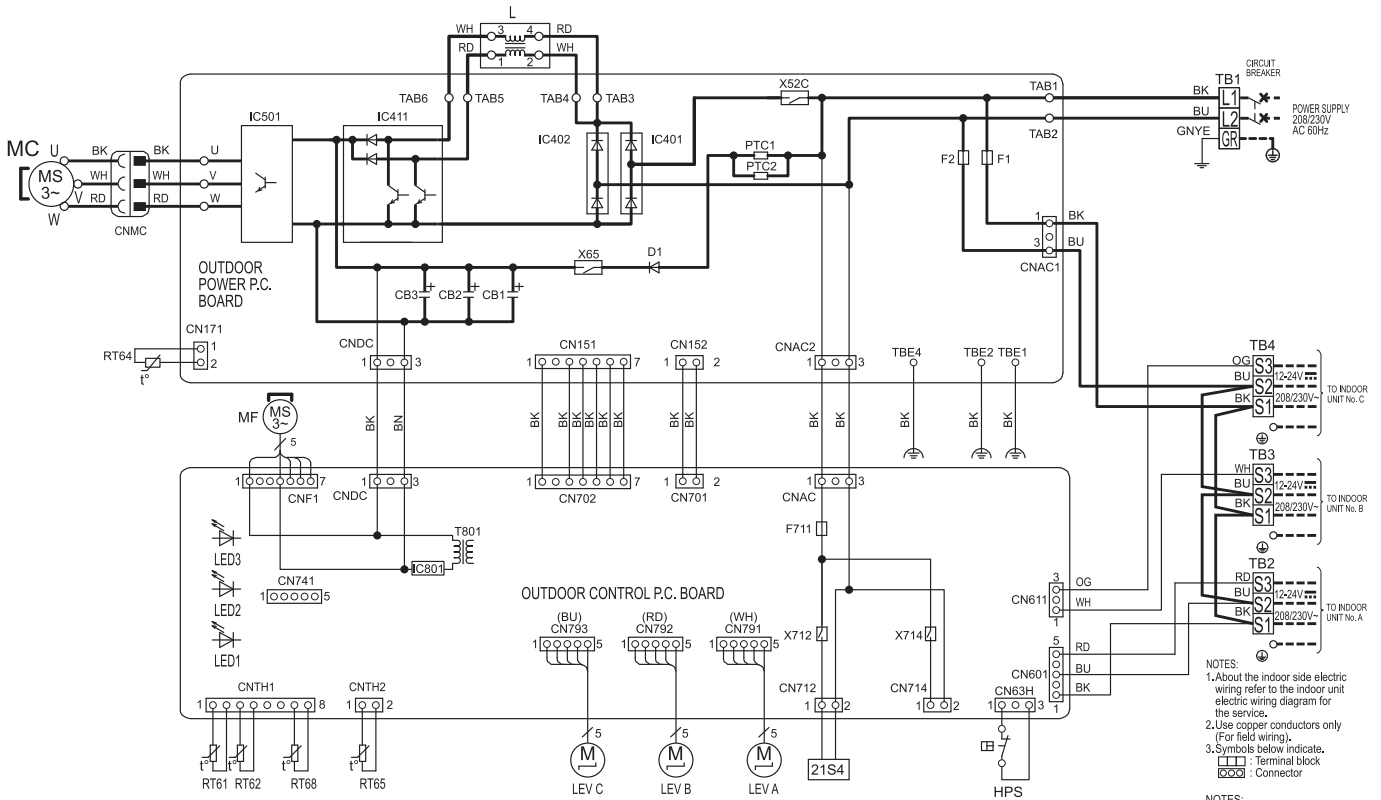

SYMBOL	NAME	SYMBOL	NAME	SYMBOL	NAME	SYMBOL	NAME	SYMBOL	NAME
CB1-3	SMOOTHING CAPACITOR	IC401, 402	DIODE BRIDGE	LEV A-C	EXPANSION VALVE COIL	RT64	FIN TEMP. THERMISTOR	X52C	RELAY
D1	DIODE	IC411	POWER FACTOR CONTROLLER	MC	COMPRESSOR	RT65	AMBIENT TEMP. THERMISTOR	X65	RELAY
F1	FUSE (T6.3AL 250V)	IC501	POWER MODULE	MF	FAN MOTOR	RT68	OUTDOOR HEAT EXCHANGER	X712	RELAY
F2	FUSE (T6.3AL 250V)	IC801	POWER DEVICE	PTC1, 2	CIRCUIT PROTECTOR		TEMP. THERMISTOR	X714	RELAY
F711	FUSE (T3.15AL 250V)	L	REACTOR	RT61	DEFROST THERMISTOR	T801	TRANSFORMER		REVERSING VALVE SOLENOID COIL
HPS	HIGH PRESSURE SWITCH	LED1-3	LED	RT62	DISCHARGE TEMP. THERMISTOR	TB1-4	TERMINAL BLOCK	21S4	

- NOTES:
- About the indoor side electric wiring refer to the indoor unit electric wiring diagram for the service.
 - Use copper conductors only (For field wiring).
 - Symbols below indicate.
 - Terminal block
 - Connector
- NOTES:
- A propos du câblage électrique de côté intérieur se référer à l'unité intérieure câblage schéma électrique pour l'entretien.
 - Utiliser des conducteurs en cuivre (Pour le câblage).
 - Symbole ci-dessous indique.
 - Bornier
 - Connecteur

[If the reactor does not have a number display, refer to the figure below.]

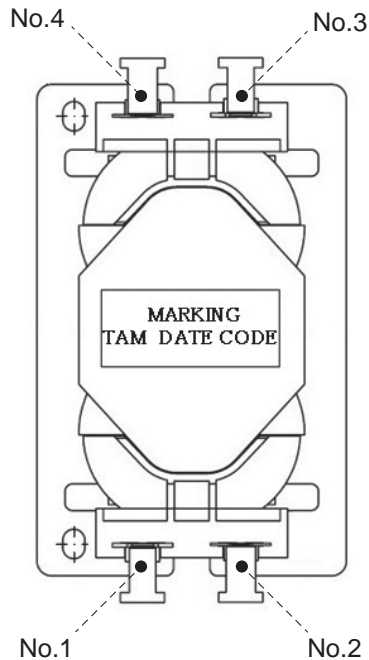

MXZ-3C24NA4 MXZ-3C30NA4

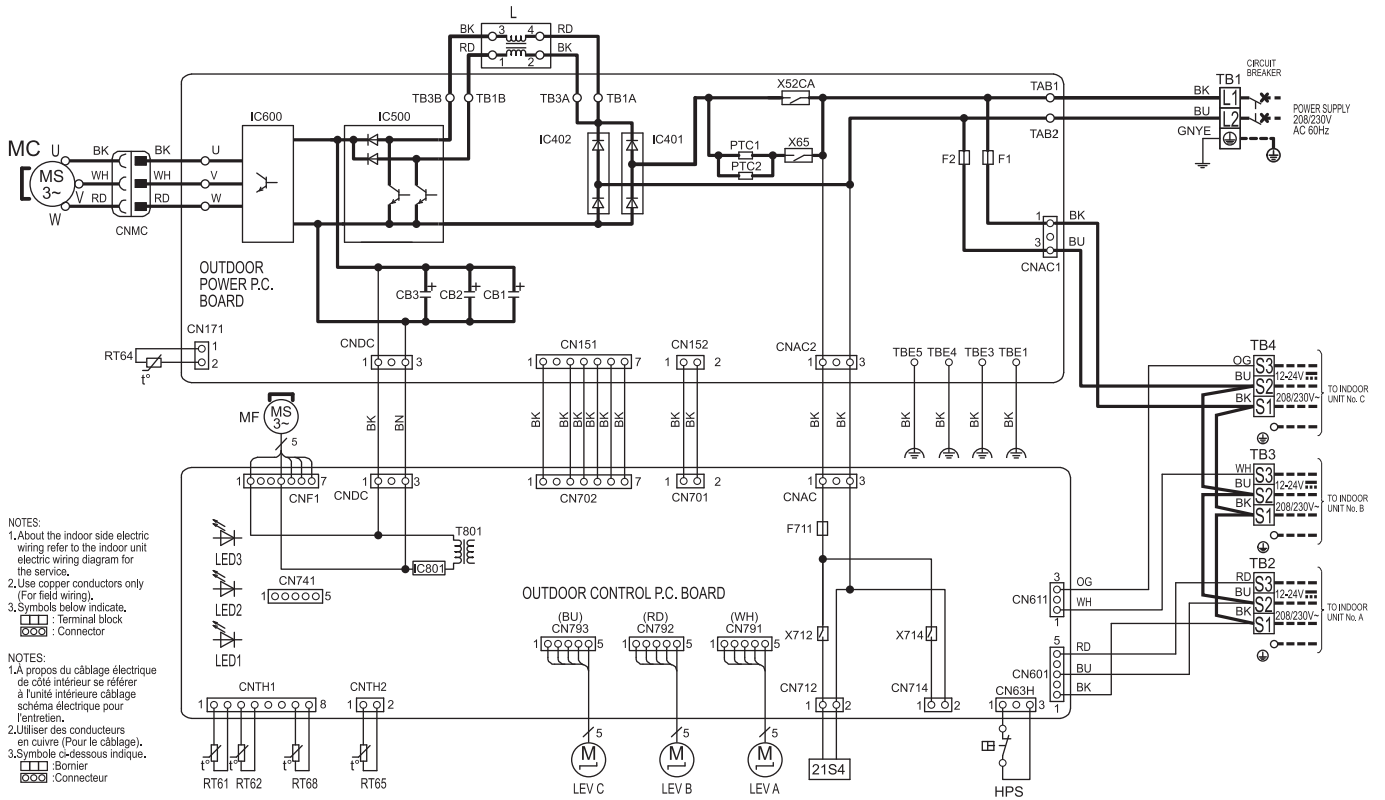

- NOTES:
1. About the indoor side electric wiring refer to the indoor unit electric wiring diagram for the service.
 2. Use copper conductors only (For field wiring).
 3. Symbols below indicate,
 - : Terminal block
 - : Connector
- NOTES:
1. À propos du câblage électrique de côté intérieur se référer à l'unité intérieure câblage schéma électrique pour l'entretien.
 2. Utiliser des conducteurs en cuivre (Pour le câblage).
 3. Symbole ci-dessous indique,
 - : Bornier
 - : Connecteur

SYMBOL	NAME	SYMBOL	NAME	SYMBOL	NAME	SYMBOL	NAME	SYMBOL	NAME	SYMBOL	NAME
CB1-3	SMOOTHING CAPACITOR	HPS	HIGH PRESSURE SWITCH	L	REACTOR	PTC1, 2	CIRCUIT PROTECTOR	RT68	OUTDOOR HEAT EXCHANGER	X65	RELAY
F1	FUSE (10A 250V)	IC401, 402	DIODE BRIDGE	LED1-3	LED	RT61	DEFROST THERMISTOR	RT68	TEMP. THERMISTOR	X712	RELAY
F2	FUSE (10A 250V)	IC500	POWER FACTOR CONTROLLER	LEV A-D	EXPANSION VALVE COIL	RT62	DISCHARGE TEMP. THERMISTOR	T801	TRANSFORMER	X714	RELAY
F711	FUSE (T3.15AL 250V)	IC600	POWER MODULE	MC	COMPRESSOR	RT64	FIN TEMP. THERMISTOR	TB1-4	TERMINAL BLOCK	21S4	REVERSING VALVE SOLENOID COIL
		IC801	POWER DEVICE	MF	FAN MOTOR	RT65	AMBIENT TEMP. THERMISTOR	X52CA	RELAY		

[If the reactor does not have a number display, refer to the figure below.]

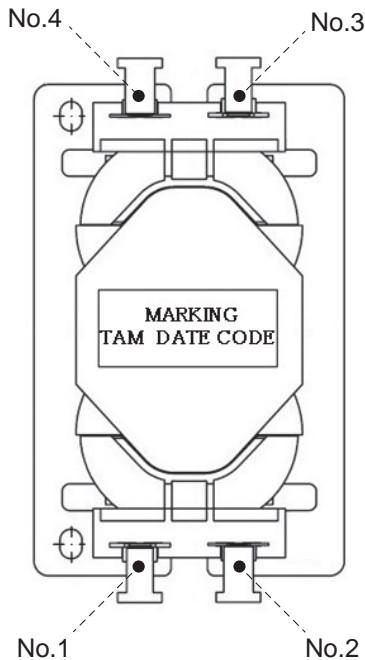

MXZ-4C36NA

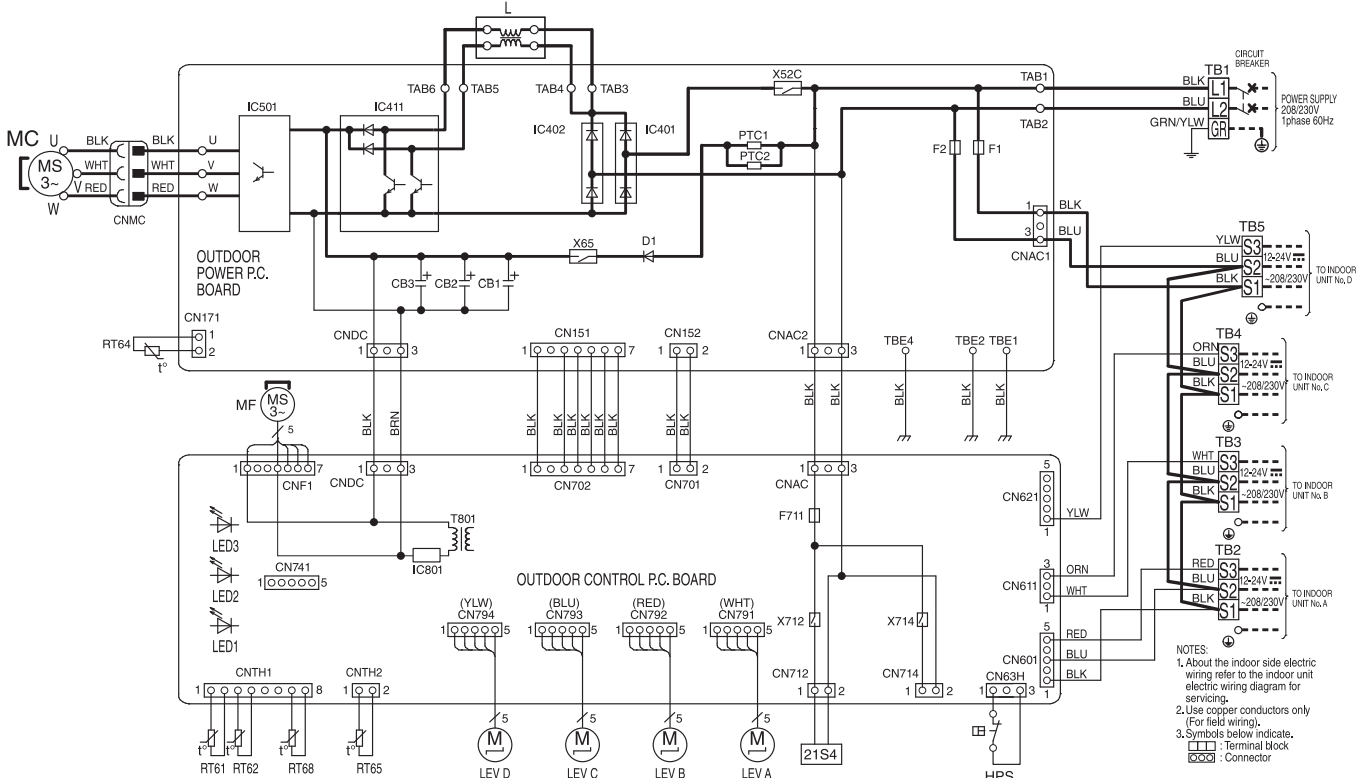

SYMBOL	NAME	SYMBOL	NAME	SYMBOL	NAME	SYMBOL	NAME	SYMBOL	NAME
CB1-3	SMOOTHING CAPACITOR	IC401, 402	DIODE BRIDGE	LEV A-D	EXPANSION VALVE COIL	RT64	FIN TEMP. THERMISTOR	X52C	RELAY
D1	DIODE	IC411	POWER FACTOR CONTROLLER	MC	COMPRESSOR	RT65	AMBIENT TEMP. THERMISTOR	X65	RELAY
F1	FUSE (T6.3AL 250V)	IC501	POWER MODULE	MF	FAN MOTOR	RT68	OUTDOOR HEAT EXCHANGER TEMPERATURE THERMISTOR	X712	RELAY
F2	FUSE (T6.3AL 250V)	IC801	POWER DEVICE	PTC1, 2	CIRCUIT PROTECTION			X714	RELAY
F711	FUSE (T3.15AL 250V)	L	REACTOR	RT61	DEFROST THERMISTOR	T801	TRANSFORMER	21S4	REVERSING VALVE SOLENOID COIL
HPS	HIGH PRESSURE SWITCH	LED1-3	LED	RT62	DISCHARGE TEMP. THERMISTOR	TB1-5	TERMINAL BLOCK		

- NOTES:
- About the indoor side electric wiring refer to the indoor unit electric wiring diagram for servicing.
 - Use copper conductors only (For field wiring).
 - Symbols below indicate.
 - Terminal block
 - Connector
- NOTES:
- A propos du câblage électrique de côté intérieur se référer à l'unité intérieure câblage schéma électrique pour l'entretien.
 - Utiliser des conducteurs en cuivre (Pour le câblage).
 - Symbole ci-dessous indique.
 - Bornier
 - Connecteur

[Connection between reactor and outdoor power P.C. board]
 * There are 2 types of reactors, which may have a number display.
 Even if there is a number display, please wire as shown in the figure below.

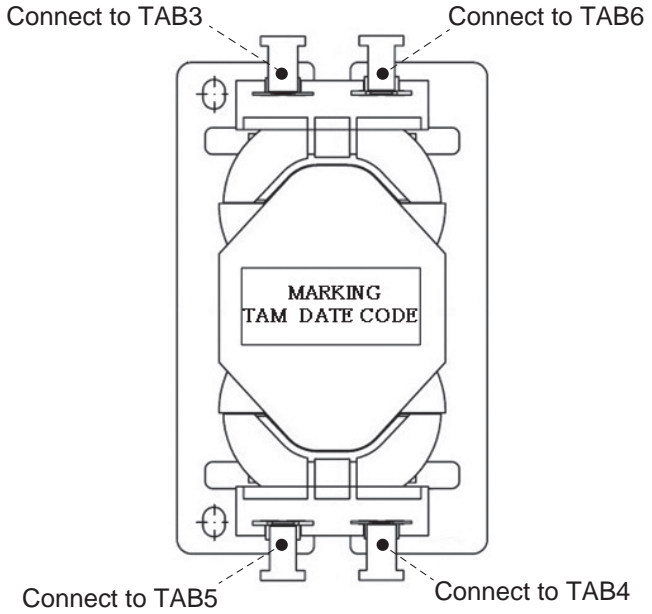

MXZ-4C36NA2

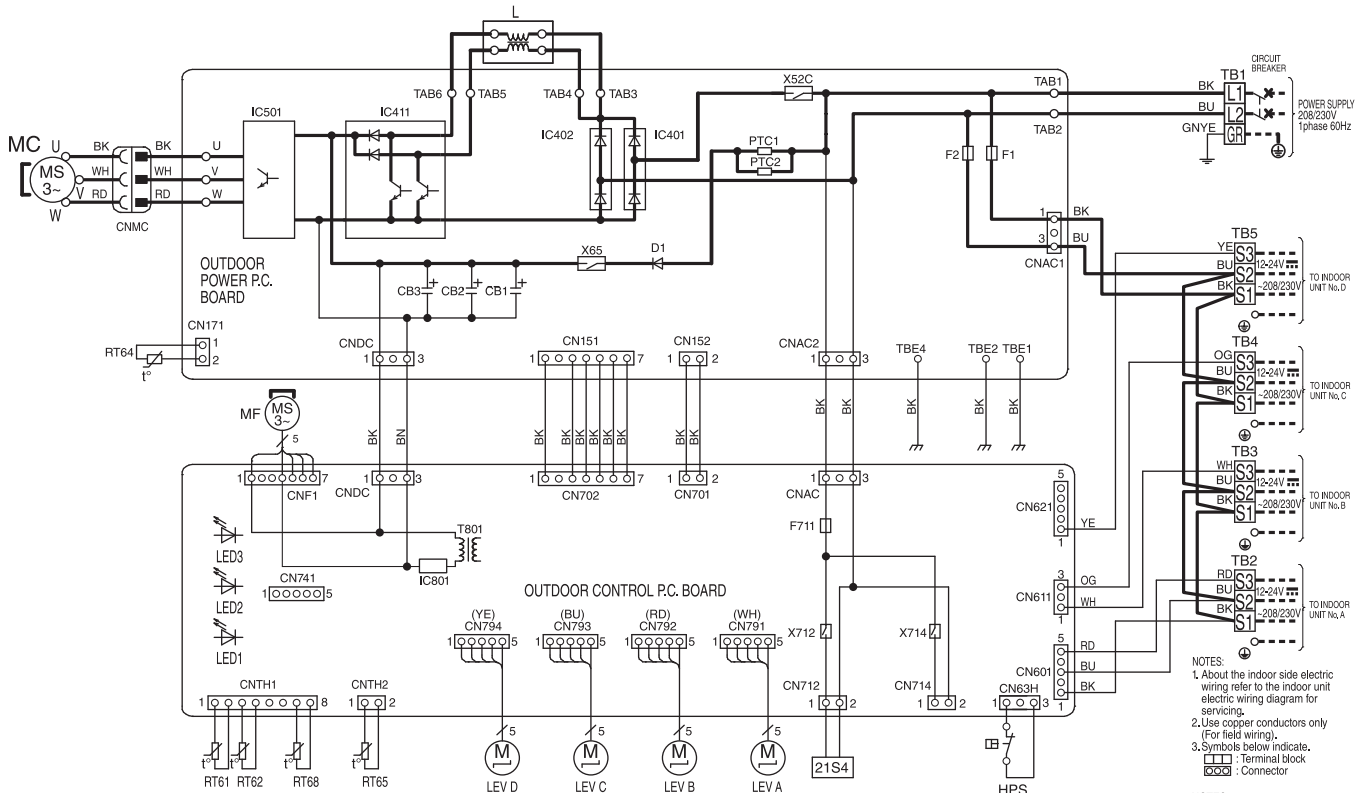

SYMBOL	NAME	SYMBOL	NAME	SYMBOL	NAME	SYMBOL	NAME	SYMBOL	NAME
CB1-3	SMOOTHING CAPACITOR	IC401, 402	DIODE BRIDGE	LEV A-D	EXPANSION VALVE COIL	RT64	FIN TEMP. THERMISTOR	X52C	RELAY
D1	DIODE	IC411	POWER FACTOR CONTROLLER	MC	COMPRESSOR	RT65	AMBIENT TEMP. THERMISTOR	X65	RELAY
F1	FUSE (T6.3AL 250V)	IC501	POWER MODULE	MF	FAN MOTOR	RT68	OUTDOOR HEAT EXCHANGER	X712	RELAY
F2	FUSE (T6.3AL 250V)	IC801	POWER DEVICE	PTC1, 2	CIRCUIT PROTECTION		TEMPERATURE THERMISTOR	X714	RELAY
F711	FUSE (T3.15AL 250V)	L	REACTOR	RT61	DEFROST THERMISTOR	T801	TRANSFORMER		REVERSING VALVE SOLENOID COIL
HPS	HIGH PRESSURE SWITCH	LED1-3	LED	RT62	DISCHARGE TEMP. THERMISTOR	TB1-5	TERMINAL BLOCK	21S4	

- NOTES:
- About the indoor side electric wiring refer to the indoor unit electric wiring diagram for servicing.
 - Use copper conductors only (For field wiring).
 - Symbols below indicate.
 - Terminal block
 - Connector
- NOTES:
- À propos du câblage électrique de côté intérieur se référer à l'unité intérieure câblage schéma électrique pour l'entretien.
 - Utiliser des conducteurs en cuivre (Pour le câblage).
 - Symbole ci-dessous indique.
 - Bornier
 - Connecteur

[Connection between reactor and outdoor power P.C. board]

* There are 2 types of reactors, which may have a number display. Even if there is a number display, please wire as shown in the figure below.

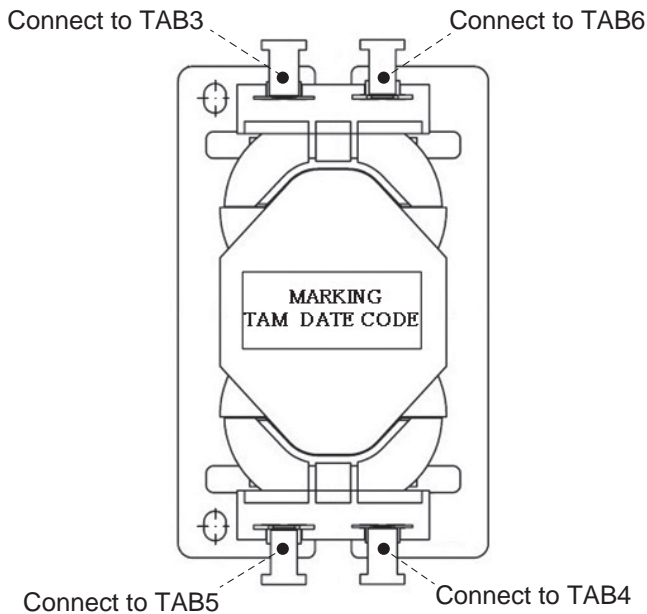

MXZ-4C36NA3

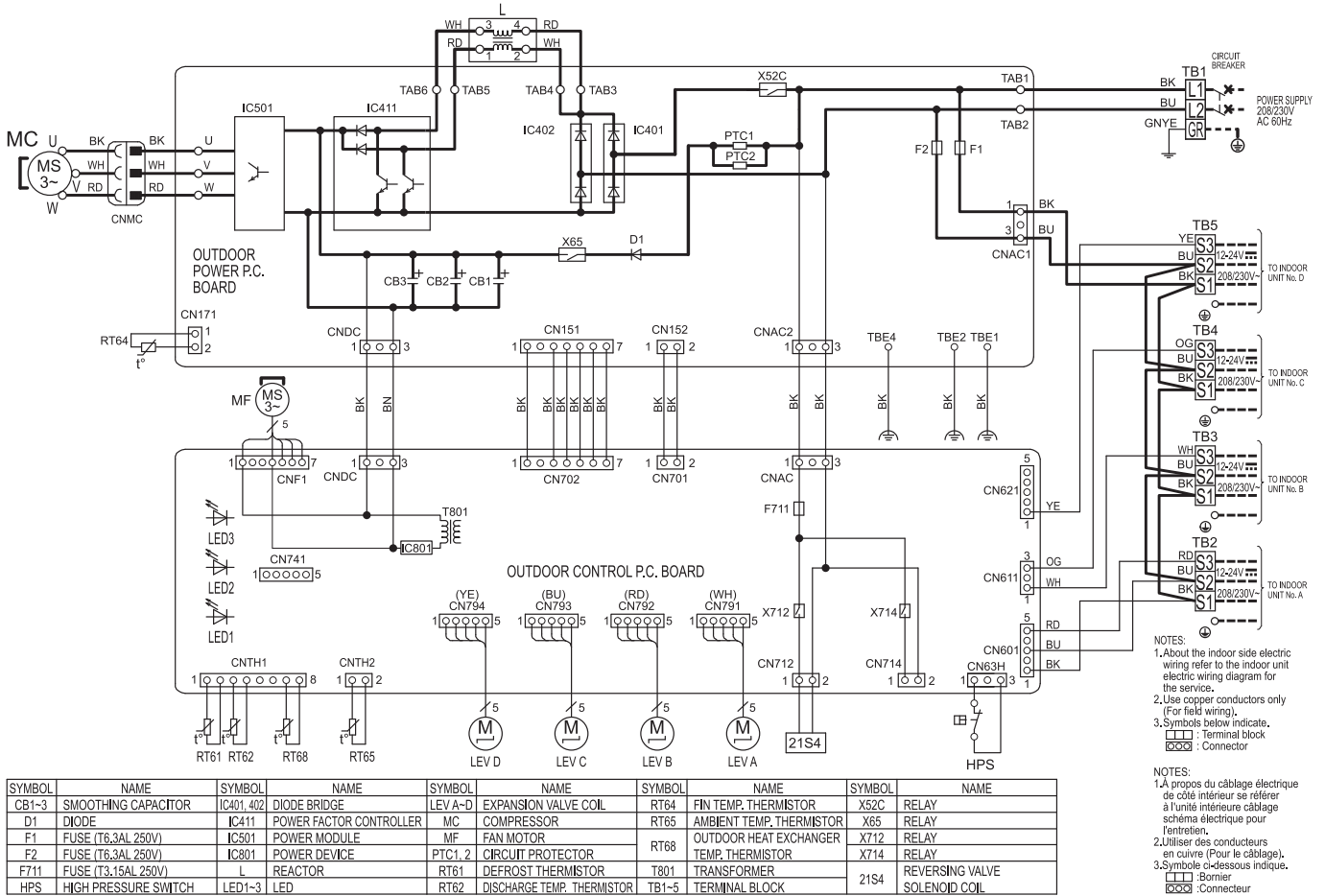

[If the reactor does not have a number display, refer to the figure below.]

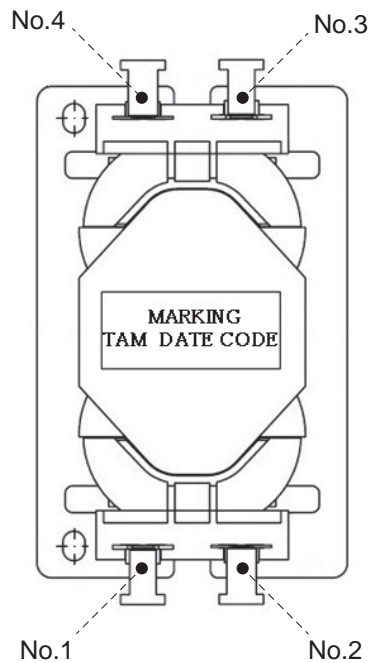

MXZ-4C36NA4

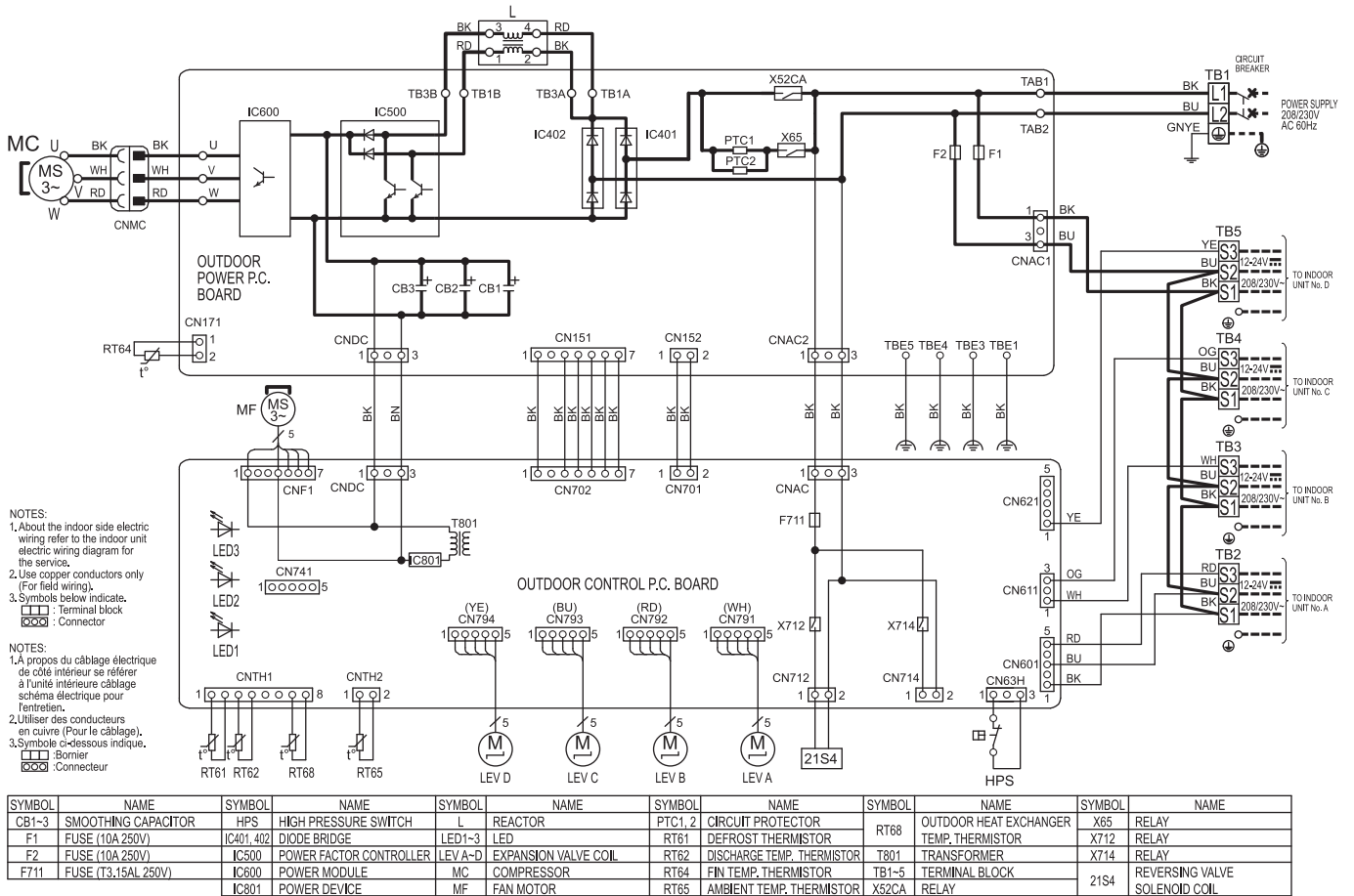

[If the reactor does not have a number display, refer to the figure below.]

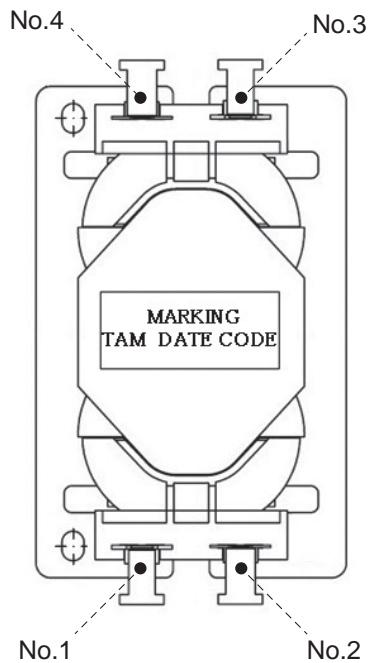

MXZ-5C42NA

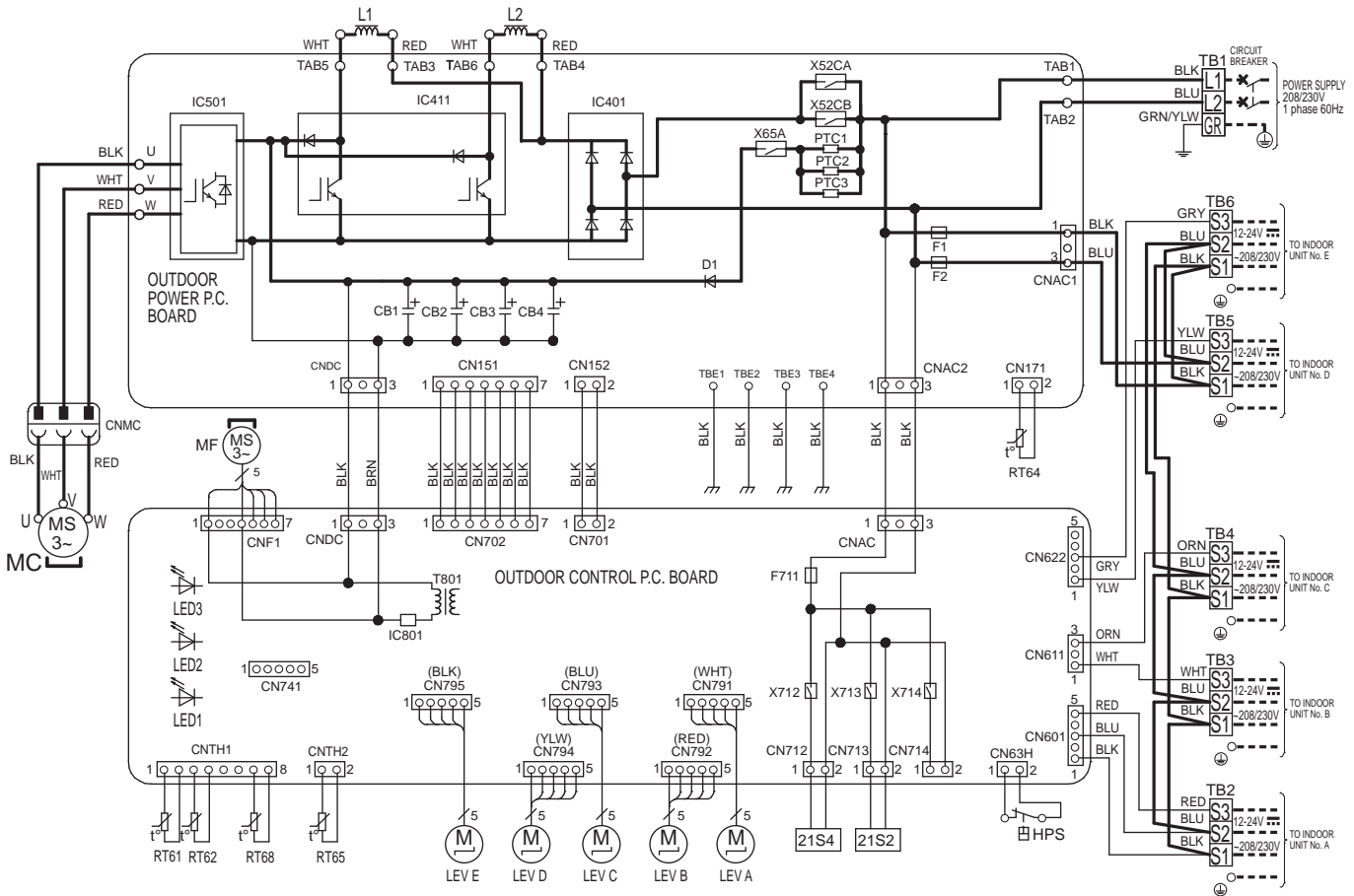

SYMBOL	NAME	SYMBOL	NAME
CB1-4	SMOOTHING CAPACITOR	L1, L2	REACTOR
D1	DIODE	LED 1-3	LED
F1, F2	FUSE (T6.3AL 250V)	LEV A-E	EXPANSION VALVE
F711	FUSE (T3.15AL 250V)	MC	COMPRESSOR
HPS	HIGH PRESSURE SWITCH	MF	FAN MOTOR
IC401	DIODE BRIDGE	T801	TRANSFORMER
IC411	POWER MODULE	TB1-6	TERMINAL BLOCK
IC501	POWER MODULE	X52CA, B	RELAY
IC801	POWER DEVICE	X65A	RELAY
PTC1-3	CIRCUIT PROTECTION	X712	RELAY
RT61	DEFROST THERMISTOR	X713	RELAY
RT62	DISCHARGE TEMP. THERMISTOR	X714	RELAY
RT64	FIN TEMP. THERMISTOR	21S2	2WAY VALVE SOLENOID COIL
RT65	AMBIENT TEMP. THERMISTOR	21S4	REVERSING VALVE SOLENOID COIL
RT68	OUTDOOR HEAT EXCHANGER TEMPERATURE THERMISTOR		

NOTES:

- About the indoor side electric wiring refer to the indoor unit electric wiring diagram for servicing.
- Use copper conductors only (For field wiring).
- Symbols below indicate.

□ : Terminal block
 ○○ : connector

NOTES:

- À propos du câblage électrique de côté intérieur se référer à l'unité intérieure câblage schéma électrique pour l'entretien.
- Utiliser des conducteurs en cuivre (pour le câblage).
- Symbole ci-dessous indique.

□ : bornier
 ○○ : connecteur

MXZ-5C42NA2

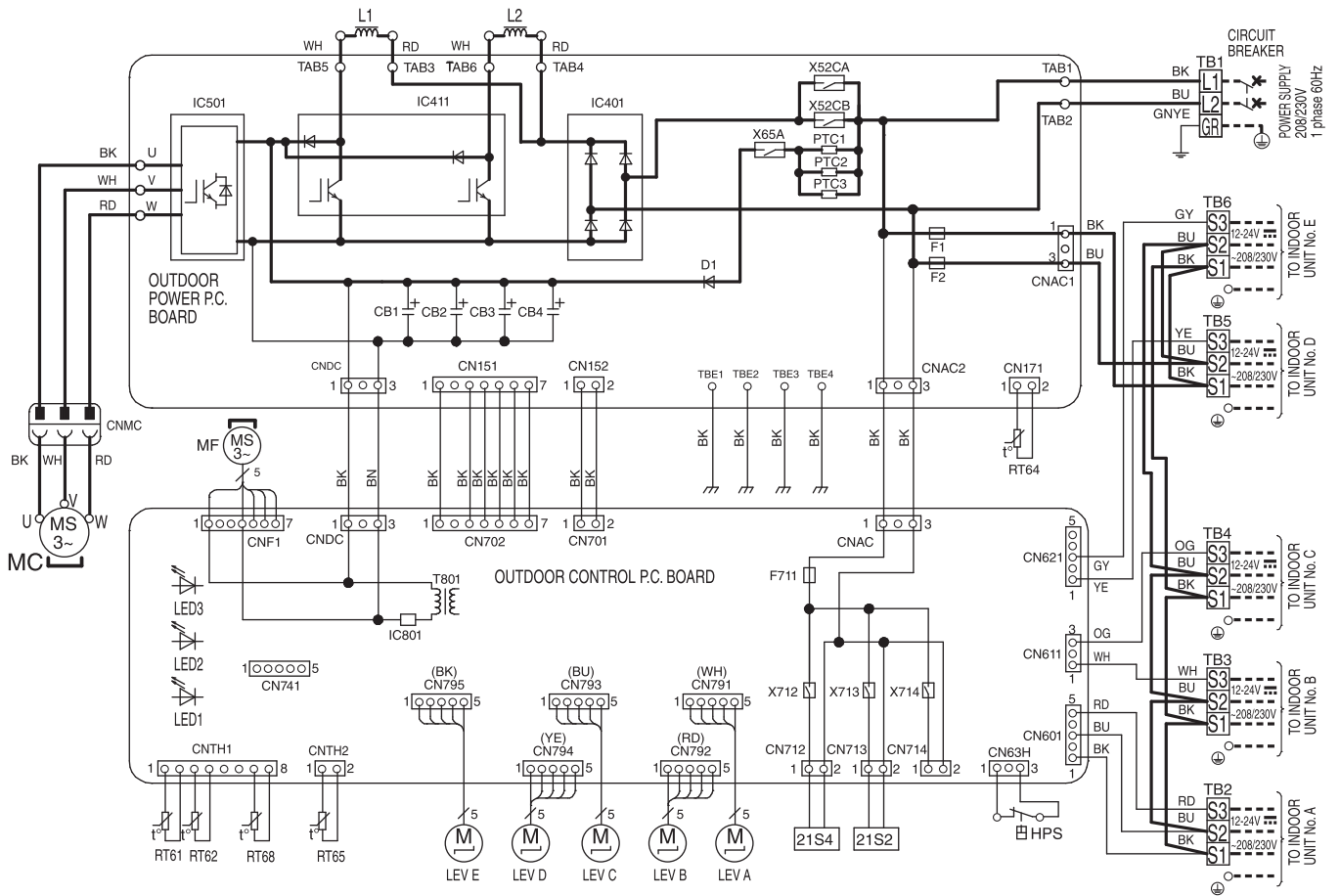

SYMBOL	NAME	SYMBOL	NAME
CB1-4	SMOOTHING CAPACITOR	RT62	DISCHARGE TEMP. THERMISTOR
D1	DIODE	RT64	FIN TEMP. THERMISTOR
F1, F2	FUSE (T6.3AL 250V)	RT65	AMBIENT TEMP. THERMISTOR
F711	FUSE (T3.15AL 250V)	RT68	OUTDOOR HEAT EXCHANGER TEMPERATURE THERMISTOR
HPS	HIGH PRESSURE SWITCH	T801	TRANSFORMER
IC401	DIODE BRIDGE	TB1-6	TERMINAL BLOCK
IC411	POWER MODULE	X52CA, B	RELAY
IC501	POWER MODULE	X65A	RELAY
IC801	POWER DEVICE	X712	RELAY
L1, L2	REACTOR	X713	RELAY
LED 1-3	LED	X714	RELAY
LEV A-E	EXPANSION VALVE COIL	21S2	2WAY VALVE SOLENOID COIL
MC	COMPRESSOR	21S4	REVERSING VALVE SOLENOID COIL
MF	FAN MOTOR		
PTC1-3	CIRCUIT PROTECTION		
RT61	DEFROST THERMISTOR		

NOTES:

- About the indoor side electric wiring refer to the indoor unit electric wiring diagram for servicing.
- Use copper conductors only (For field wiring).
- Symbols below indicate.
 : Terminal block
 : Connector

NOTES:

- À propos du câblage électrique de côté intérieur se référer à l'unité intérieure câblage schéma électrique pour l'entretien.
- Utiliser des conducteurs en cuivre (pour le câblage).
- Symbole ci-dessous indique.
 : Bornier
 : Connecteur

MXZ-5C42NA3

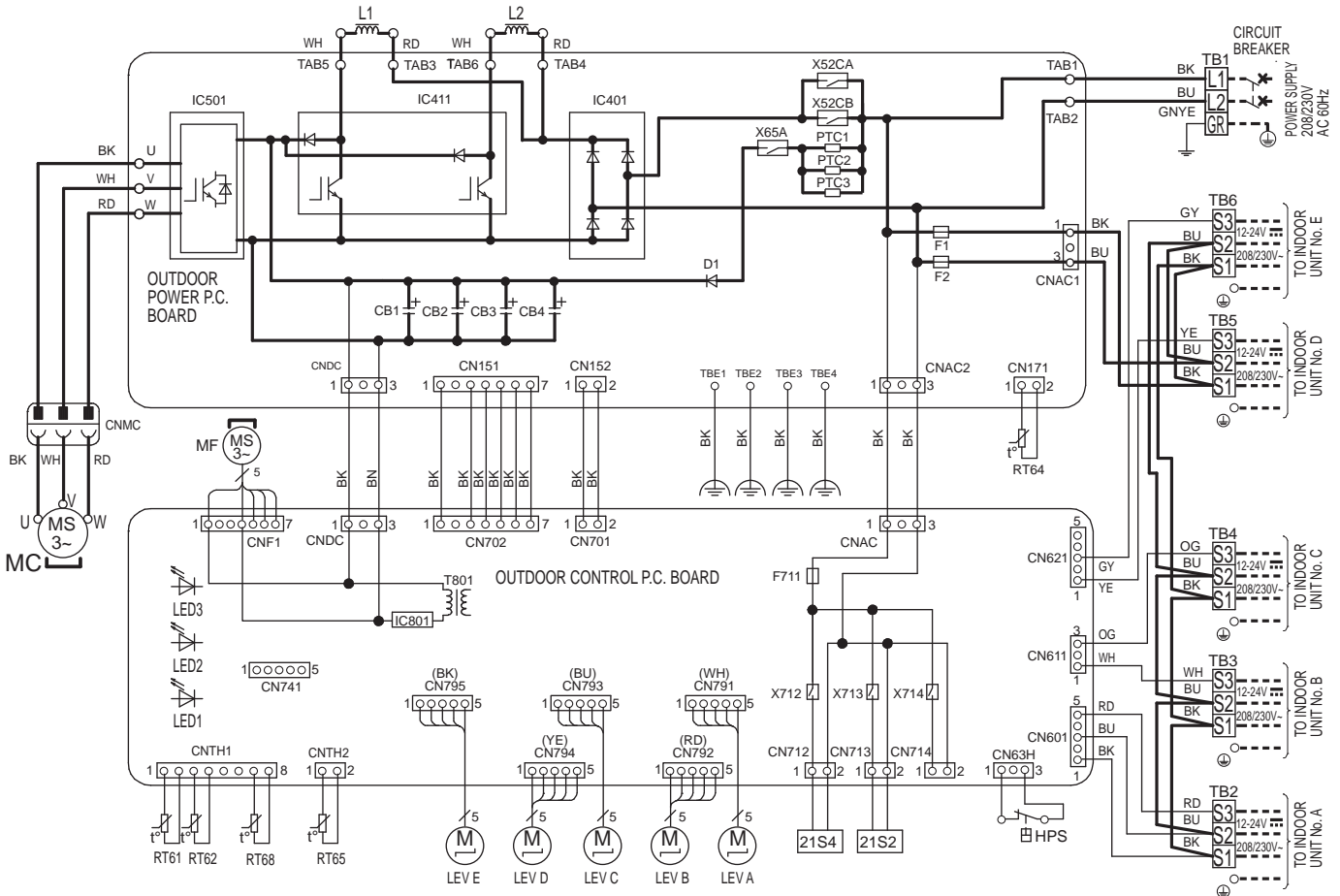

SYMBOL	NAME	SYMBOL	NAME
CB1-4	SMOOTHING CAPACITOR	RT62	DISCHARGE TEMP. THERMISTOR
D1	DIODE	RT64	FIN TEMP. THERMISTOR
F1, F2	FUSE (T6.3AL 250V)	RT65	AMBIENT TEMP. THERMISTOR
F711	FUSE (T3.15AL 250V)	RT68	OUTDOOR HEAT EXCHANGER TEMP. THERMISTOR
HPS	HIGH PRESSURE SWITCH	T801	TRANSFORMER
IC401	DIODE BRIDGE	TB1-6	TERMINAL BLOCK
IC411	POWER MODULE	X52CA, B	RELAY
IC501	POWER MODULE	X65A	RELAY
IC801	POWER DEVICE	X712	RELAY
L1, L2	REACTOR	X713	RELAY
LED 1-3	LED	X714	RELAY
LEV A-E	EXPANSION VALVE COIL	21S2	2WAY VALVE SOLENOID COIL
MC	COMPRESSOR	21S4	REVERSING VALVE SOLENOID COIL
MF	FAN MOTOR		
PTC1-3	CIRCUIT PROTECTOR		
RT61	DEFROST THERMISTOR		

- NOTES:
- About the indoor side electric wiring refer to the indoor unit electric wiring diagram for the service.
 - Use copper conductors only (For field wiring).
 - Symbols below indicate.
 : Terminal block
 : Connector

- NOTES:
- A propos du câblage électrique de côté intérieur se référer à l'unité intérieure câblage schéma électrique pour l'entretien.
 - Utiliser des conducteurs en cuivre (pour le câblage).
 - Symbole ci-dessous indique.
 : Bornier
 : Connecteur

MXZ-5C42NA4

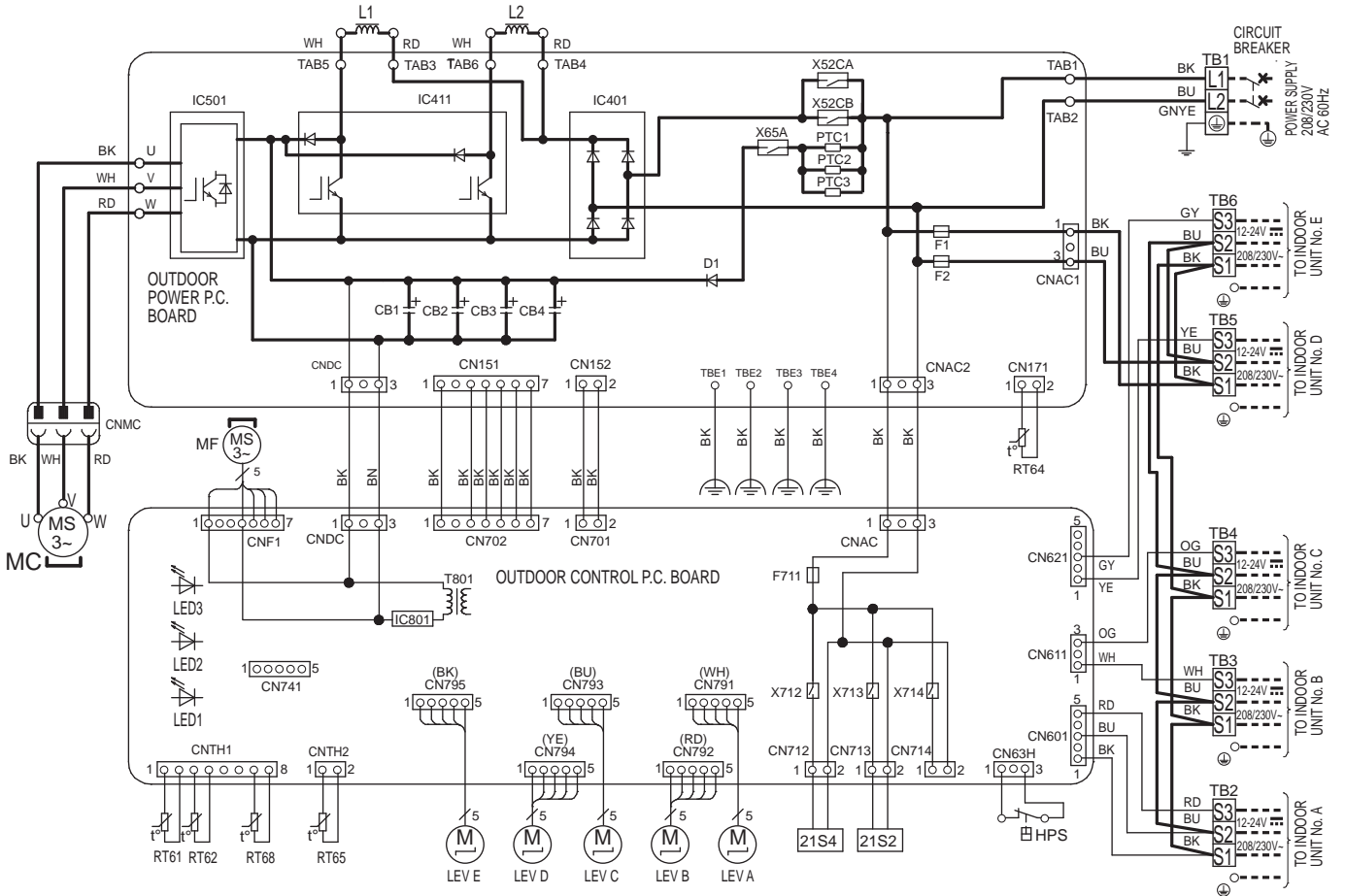

SYMBOL	NAME	SYMBOL	NAME
CB1-4	SMOOTHING CAPACITOR	RT62	DISCHARGE TEMP. THERMISTOR
D1	DIODE	RT64	FIN TEMP. THERMISTOR
F1, F2	FUSE (T6.3AL 250V)	RT65	AMBIENT TEMP. THERMISTOR
F711	FUSE (T3.15AL 250V)	RT68	OUTDOOR HEAT EXCHANGER TEMP. THERMISTOR
HPS	HIGH PRESSURE SWITCH	T801	TRANSFORMER
IC401	DIODE BRIDGE	TB1-6	TERMINAL BLOCK
IC411	POWER MODULE	X52CA, B	RELAY
IC501	POWER MODULE	X65A	RELAY
IC801	POWER DEVICE	X712	RELAY
L1, L2	REACTOR	X713	RELAY
LED 1-3	LED	X714	RELAY
LEV A-E	EXPANSION VALVE COIL	21S2	2-WAY VALVE SOLENOID COIL
MC	COMPRESSOR	21S4	4-WAY VALVE SOLENOID COIL
MF	FAN MOTOR		
PTC1-3	CIRCUIT PROTECTOR		
RT61	DEFROST THERMISTOR		

NOTES:

1. About the indoor side electric wiring refer to the indoor unit electric wiring diagram for the service.
2. Use copper conductors only (For field wiring).
3. Symbols below indicate.

: Terminal block
 : Connector

NOTES:

1. À propos du câblage électrique de côté intérieur se référer à l'unité intérieure câblage schéma électrique pour l'entretien.
2. Utiliser des conducteurs en cuivre (pour le câblage).
3. Symbole ci-dessous indique.

: Bornier
 : Connecteur

MXZ-2C20NAHZ

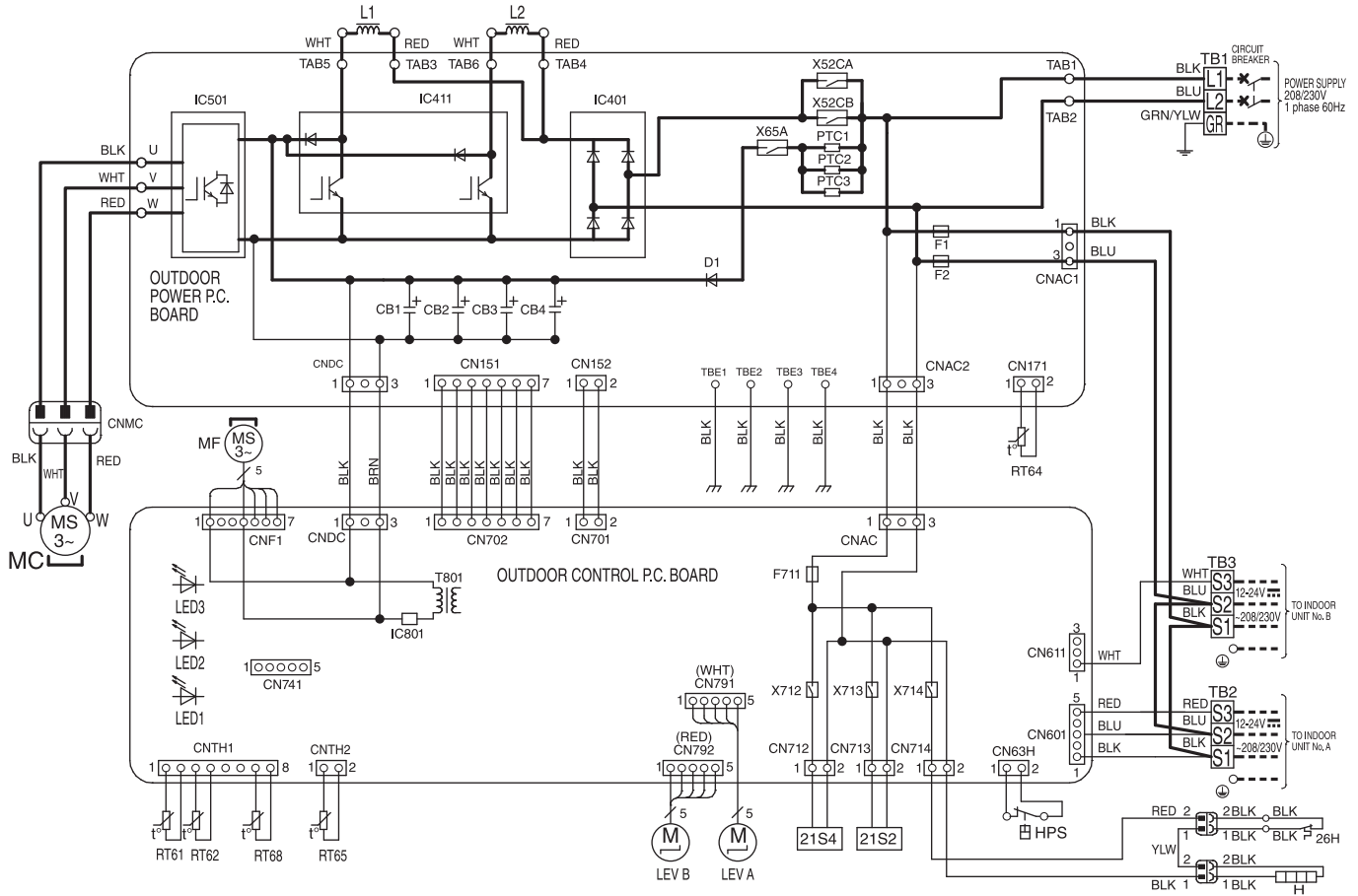

SYMBOL	NAME	SYMBOL	NAME
CB1-4	SMOOTHING CAPACITOR	L1, L2	REACTOR
D1	DIODE	LED 1-3	LED
F1, F2	FUSE (T6.3AL 250V)	LEV A, B	EXPANSION VALVE
F711	FUSE (T3.15AL 250V)	MC	COMPRESSOR
HPS	HIGH PRESSURE SWITCH	MF	FAN MOTOR
IC401	DIODE BRIDGE	T801	TRANSFORMER
IC411	POWER MODULE	TB1-3	TERMINAL BLOCK
IC501	POWER MODULE	X52CA, B	RELAY
IC801	POWER DEVICE	X65A	RELAY
PTC1-3	CIRCUIT PROTECTION	X712	RELAY
RT61	DEFROST THERMISTOR	X713	RELAY
RT62	DISCHARGE TEMP.THERMISTOR	X714	RELAY
RT64	FIN TEMP.THERMISTOR	21S2	2WAY VALVE SOLENOID COIL
RT65	AMBIENT TEMP.THERMISTOR	21S4	REVERSING VALVE SOLENOID COIL
RT68	OUTDOOR HEAT EXCHANGER TEMPERATURE THERMISTOR	26H	HEATER PROTECTOR
		H	DEFROST HEATER

NOTES:

- About the indoor side electric wiring refer to the indoor unit electric wiring diagram for servicing.
- Use copper conductors only (For field wiring).
- Symbols below indicate.
 - : Terminal block
 - ⊗: connector

NOTES:

- À propos du câblage électrique de côté intérieur se référer à l'unité intérieure câblage schéma électrique pour l'entretien.
- Utiliser des conducteurs en cuivre (pour le câblage).
- Symbole ci-dessous indique.
 - : bornier
 - ⊗: connecteur

MXZ-2C20NAH22

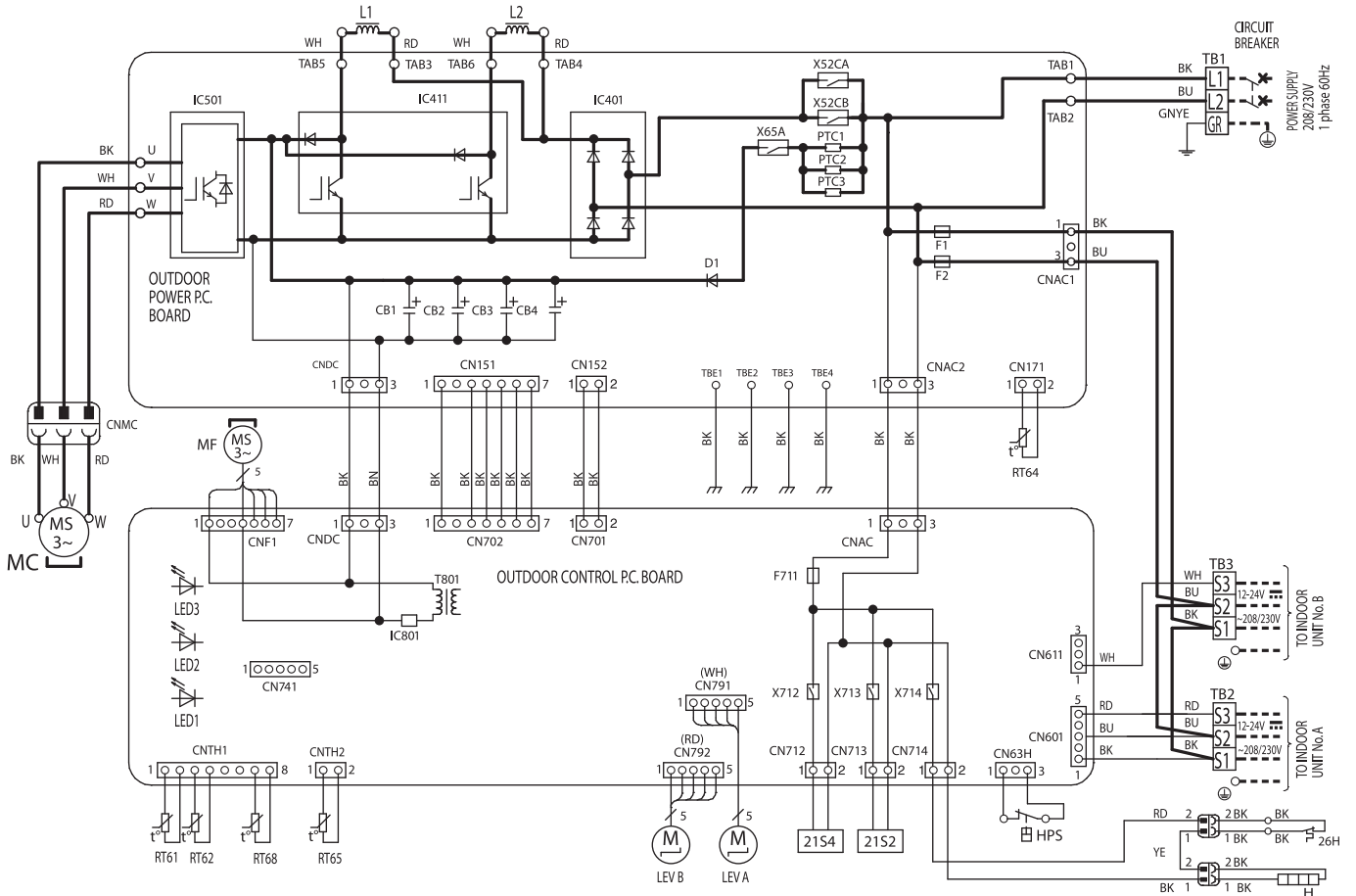

SYMBOL	NAME	SYMBOL	NAME
CB1~4	SMOOTHING CAPACITOR	RT61	DEFROST THERMISTOR
D1	DIODE	RT62	DISCHARGE TEMP.THERMISTOR
F1, F2	FUSE (T6.3AL 250V)	RT64	FIN TEMP.THERMISTOR
F711	FUSE (T3.15AL 250V)	RT65	AMBIENT TEMP.THERMISTOR
HPS	HIGH PRESSURE SWITCH	RT 68	OUTDOOR HEAT EXCHANGER TEMPERATURE THERMISTOR
H	DEFROST HEATER		
IC401	DIODE BRIDGE	T801	TRANSFORMER
IC411	POWER MODULE	TB1~3	TERMINAL BLOCK
IC501	POWER MODULE	X52CA, B	RELAY
IC801	POWER DEVICE	X65A	RELAY
L1, L2	REACTOR	X712	RELAY
LED 1~3	LED	X713	RELAY
LEV A, B	EXPANSION VALVE COIL	X714	RELAY
MC	COMPRESSOR	21S2	2WAY VALVE SOLENOID COIL
MF	FAN MOTOR	21S4	REVERSING VALVE SOLENOID COIL
PTC1~3	CIRCUIT PROTECTION	26H	HEATER PROTECTOR

NOTES:

- About the indoor side electric wiring refer to the indoor unit electric wiring diagram for servicing.
- Use copper conductors only (For field wiring).
- Symbols below indicate.
 - : Terminal block
 - : Connector

NOTES:

- À propos du câblage électrique de côté intérieur se référer à l'unité intérieure câblage schéma électrique pour l'entretien.
- Utiliser des conducteurs en cuivre (pour le câblage).
- Symbole ci-dessous indique.
 - : Bornier
 - : Connecteur

MXZ-2C20NAHZ3

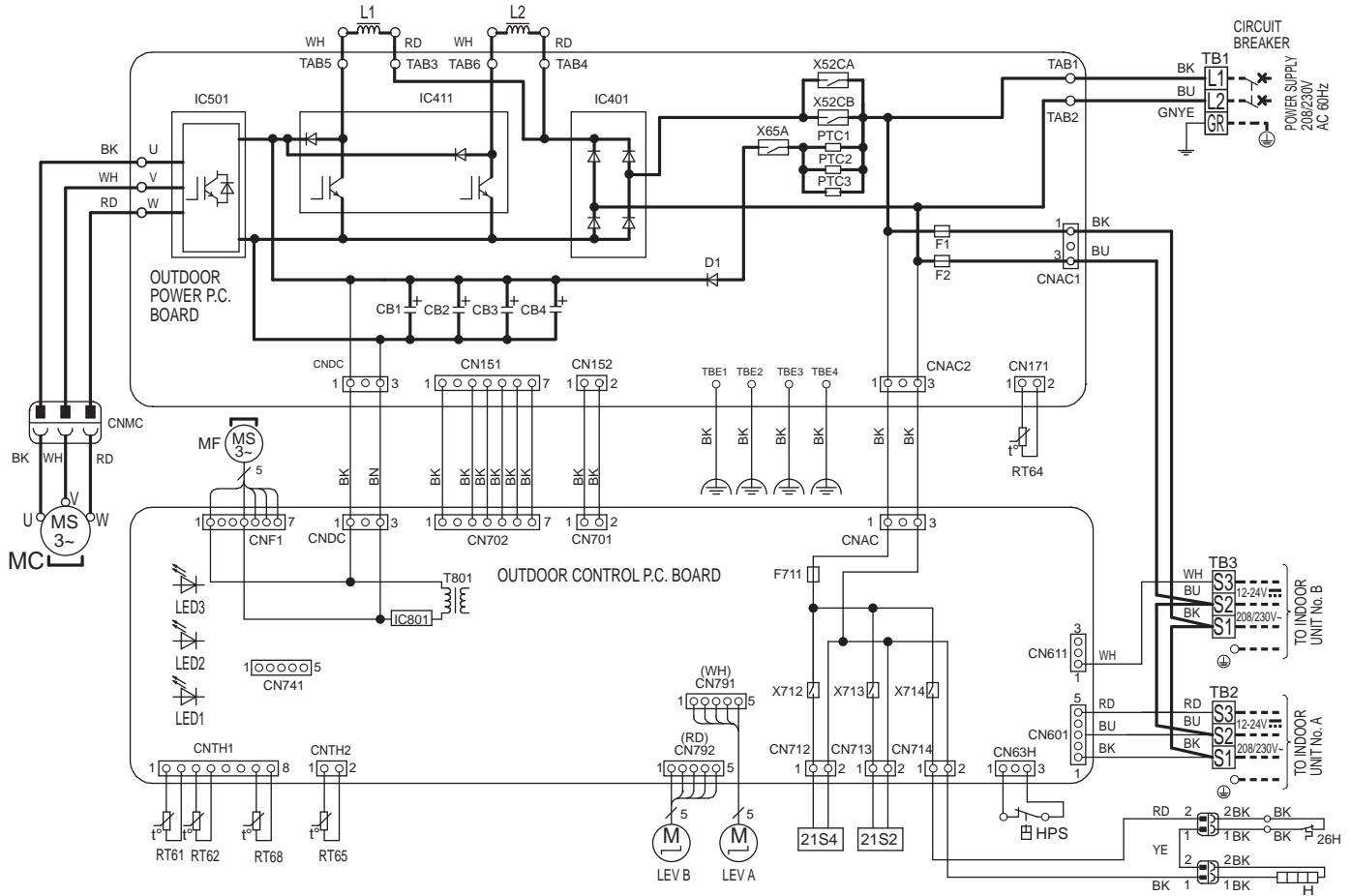

SYMBOL	NAME	SYMBOL	NAME
CB1-4	SMOOTHING CAPACITOR	RT61	DEFROST THERMISTOR
D1	DIODE	RT62	DISCHARGE TEMP. THERMISTOR
F1, F2	FUSE (T6.3AL 250V)	RT64	FIN TEMP. THERMISTOR
F711	FUSE (T3.15AL 250V)	RT65	AMBIENT TEMP. THERMISTOR
HPS	HIGH PRESSURE SWITCH	RT68	OUTDOOR HEAT EXCHANGER TEMP. THERMISTOR
H	DEFROST HEATER	T801	TRANSFORMER
IC401	DIODE BRIDGE	TB1-3	TERMINAL BLOCK
IC411	POWER MODULE	X52CA, B	RELAY
IC501	POWER MODULE	X65A	RELAY
IC801	POWER DEVICE	X712	RELAY
L1, L2	REACTOR	X713	RELAY
LED 1-3	LED	X714	RELAY
LEV A, B	EXPANSION VALVE COIL	X714	RELAY
MC	COMPRESSOR	21S2	2WAY VALVE SOLENOID COIL
MF	FAN MOTOR	21S4	REVERSING VALVE SOLENOID COIL
PTC1-3	CIRCUIT PROTECTOR	26H	HEATER PROTECTOR

NOTES:
 1. About the indoor side electric wiring refer to the indoor unit electric wiring diagram for the service.
 2. Use copper conductors only (For field wiring).
 3. Symbols below indicate.
 □: Terminal block
 ⊞: Connector

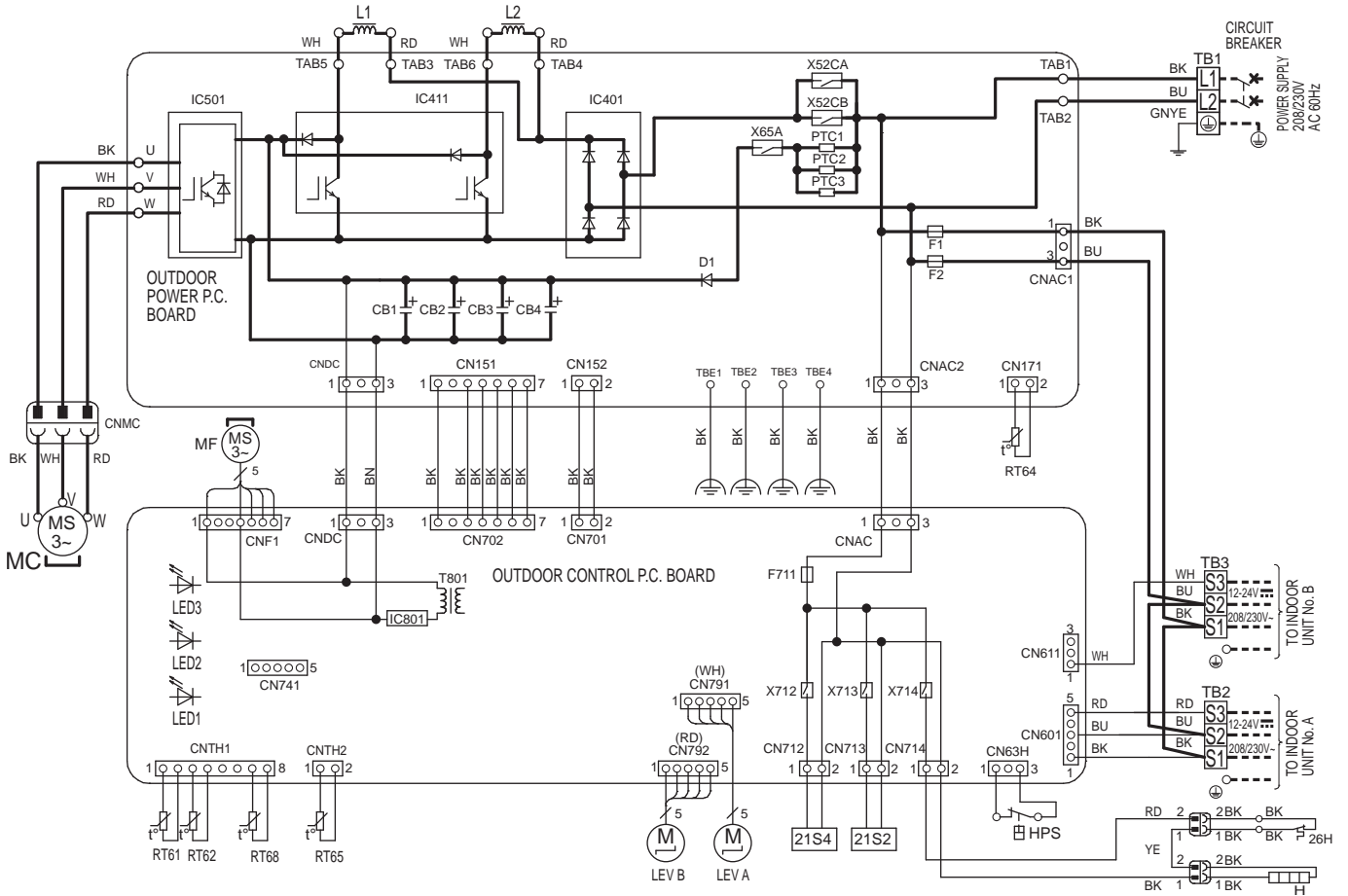

NOTES:
 1. A propos du câblage électrique de côté intérieur se référer à l'unité intérieure câblage schéma électrique pour l'entretien.
 2. Utiliser des conducteurs en cuivre (pour le câblage).
 3. Symbole ci-dessous indique.
 □: Bornier
 ⊞: Connecteur

MXZ-2C20NAHZ4





SYMBOL	NAME	SYMBOL	NAME
CB1-4	SMOOTHING CAPACITOR	RT61	DEFROST THERMISTOR
D1	DIODE	RT62	DISCHARGE TEMP. THERMISTOR
F1, F2	FUSE (T6.3AL 250V)	RT64	FIN TEMP. THERMISTOR
F711	FUSE (T3.15AL 250V)	RT65	AMBIENT TEMP. THERMISTOR
HPS	HIGH PRESSURE SWITCH	RT68	OUTDOOR HEAT EXCHANGER TEMP. THERMISTOR
H	DEFROST HEATER		
IC401	DIODE BRIDGE	T801	TRANSFORMER
IC411	POWER MODULE	TB1-3	TERMINAL BLOCK
IC501	POWER MODULE	X52CA, B	RELAY
IC801	POWER DEVICE	X65A	RELAY
L1, L2	REACTOR	X712	RELAY
LED 1-3	LED	X713	RELAY
LEV A, B	EXPANSION VALVE COIL	X714	RELAY
MC	COMPRESSOR	21S2	2-WAY VALVE SOLENOID COIL
MF	FAN MOTOR	21S4	4-WAY VALVE SOLENOID COIL
PTC1-3	CIRCUIT PROTECTOR	26H	HEATER PROTECTOR

NOTES:

- About the indoor side electric wiring refer to the indoor unit electric wiring diagram for the service.
- Use copper conductors only (For field wiring).
- Symbols below indicate.
: Terminal block
: Connector

NOTES:

- À propos du câblage électrique de côté intérieur se référer à l'unité intérieure câblage schéma électrique pour l'entretien.
- Utiliser des conducteurs en cuivre (pour le câblage).
- Symbole ci-dessous indique.
: Bornier
: Connecteur

MXZ-3C24NAHZ MXZ-3C30NAHZ

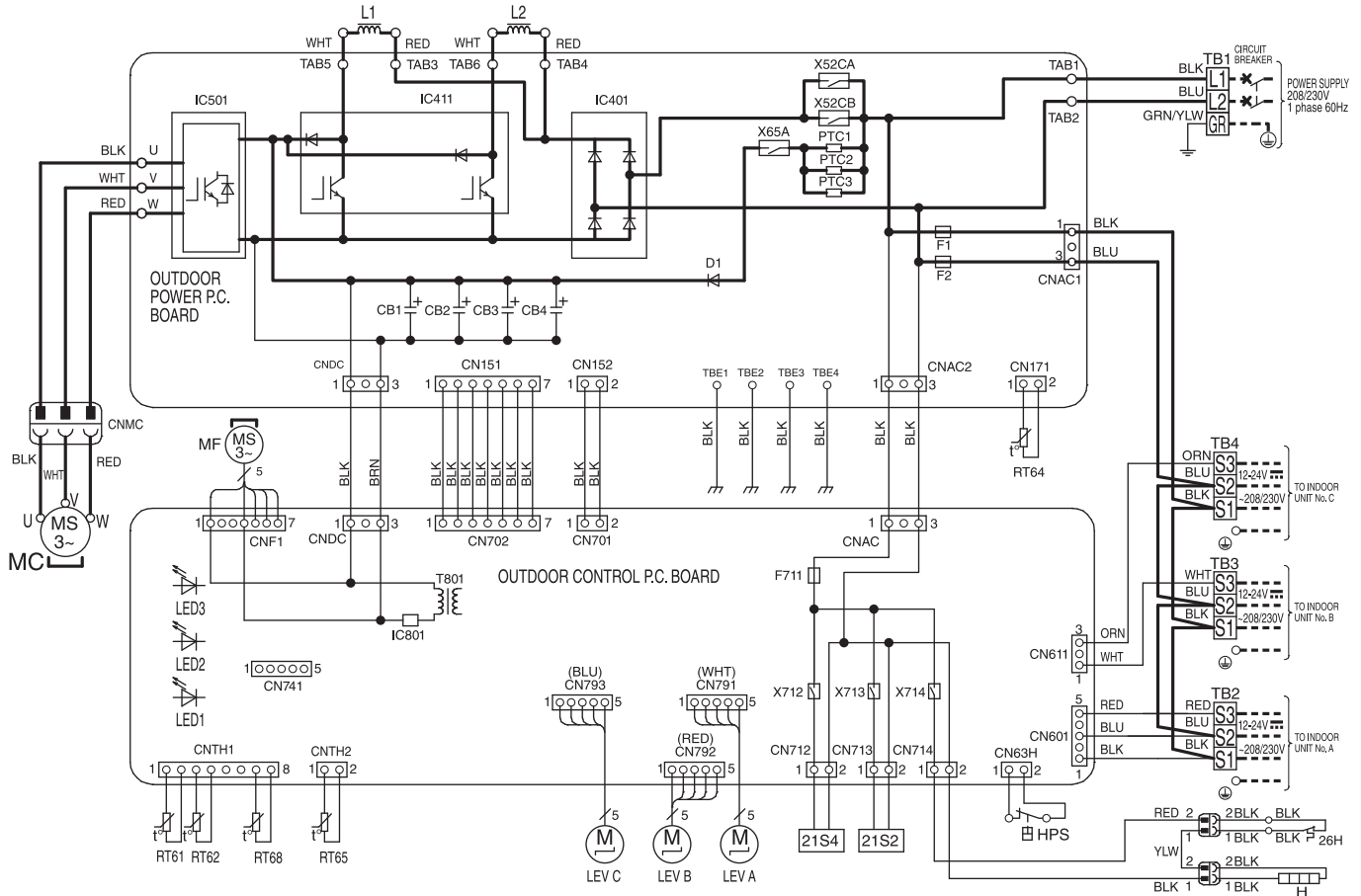

SYMBOL	NAME	SYMBOL	NAME
CB1-4	SMOOTHING CAPACITOR	L1, L2	REACTOR
D1	DIODE	LED 1-3	LED
F1, F2	FUSE (T6.3AL 250V)	LEV A-C	EXPANSION VALVE
F711	FUSE (T3.15AL 250V)	MC	COMPRESSOR
HPS	HIGH PRESSURE SWITCH	MF	FAN MOTOR
IC401	DIODE BRIDGE	T801	TRANSFORMER
IC411	POWER MODULE	TB1-4	TERMINAL BLOCK
IC501	POWER MODULE	X52CA, B	RELAY
IC801	POWER DEVICE	X65A	RELAY
PTC1-3	CIRCUIT PROTECTION	X712	RELAY
RT61	DEFROST THERMISTOR	X713	RELAY
RT62	DISCHARGE TEMP. THERMISTOR	X714	RELAY
RT64	FIN TEMP. THERMISTOR	21S2	2WAY VALVE SOLENOID COIL
RT65	AMBIENT TEMP. THERMISTOR	21S4	REVERSING VALVE SOLENOID COIL
RT68	OUTDOOR HEAT EXCHANGER TEMPERATURE THERMISTOR	26H	HEATER PROTECTOR
		H	DEFROST HEATER

NOTES:

- About the indoor side electric wiring refer to the indoor unit electric wiring diagram for servicing.
- Use copper conductors only (For field wiring).
- Symbols below indicate.
 Terminal block
 connector

NOTES:

- À propos du câblage électrique de côté intérieur se référer à l'unité intérieure câblage schéma électrique pour l'entretien.
- Utiliser des conducteurs en cuivre (pour le câblage).
- Symbole ci-dessous indique.
 bornier
 connecteur

MXZ-3C24NAHZ2 MXZ-3C30NAHZ2

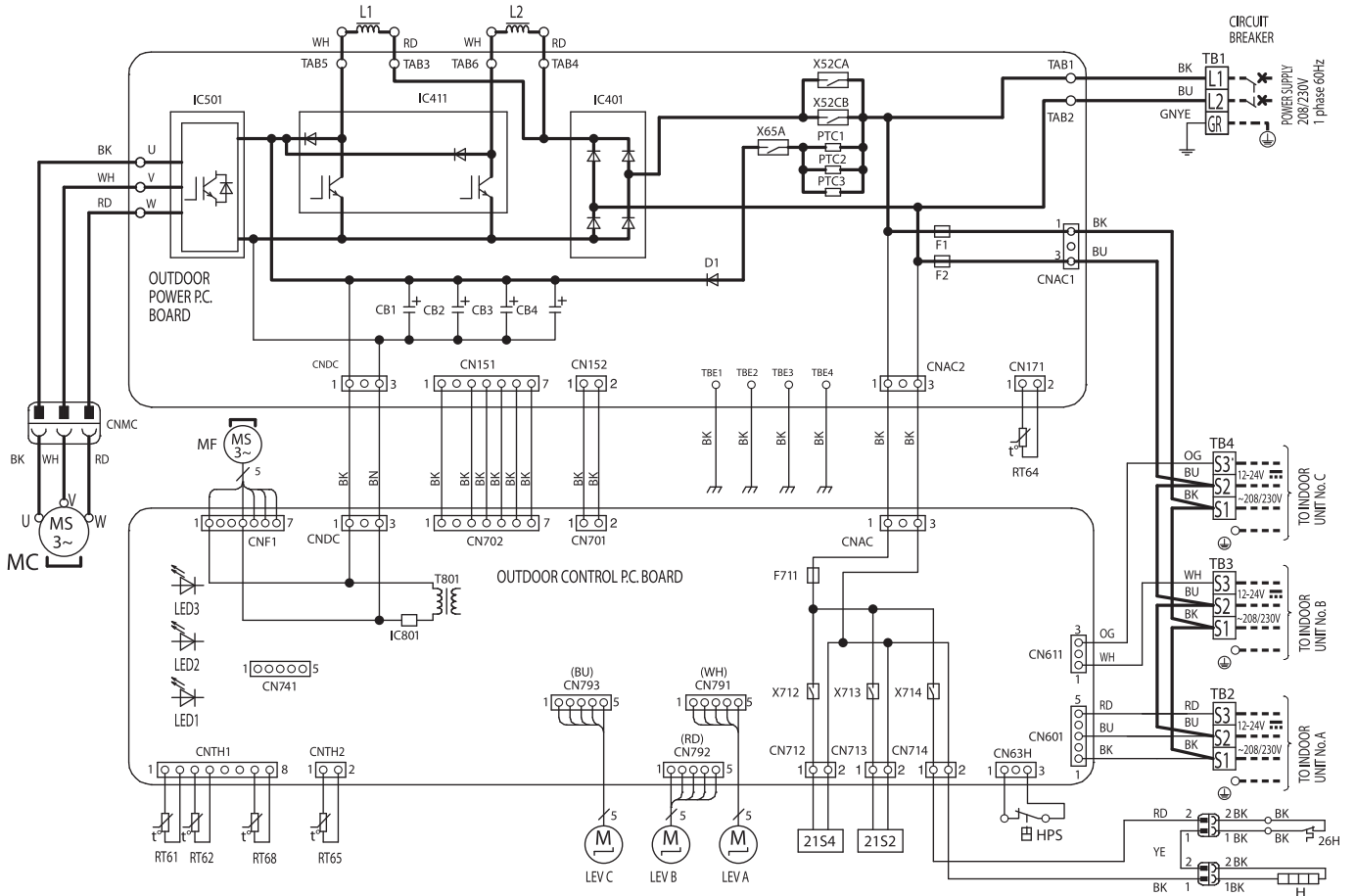

SYMBOL	NAME	SYMBOL	NAME
CB1~4	SMOOTHING CAPACITOR	RT61	DEFROST THERMISTOR
D1	DIODE	RT62	DISCHARGE TEMP.THERMISTOR
F1, F2	FUSE (T6.3AL 250V)	RT64	FIN TEMP.THERMISTOR
F711	FUSE (T3.15AL 250V)	RT65	AMBIENT TEMP.THERMISTOR
HPS	HIGH PRESSURE SWITCH	RT68	OUTDOOR HEAT EXCHANGER TEMPERATURE THERMISTOR
H	DEFROST HEATER	T801	TRANSFORMER
IC401	DIODE BRIDGE	TB1~4	TERMINAL BLOCK
IC411	POWER MODULE	X52CA, B	RELAY
IC501	POWER MODULE	X65A	RELAY
IC801	POWER DEVICE	X712	RELAY
L1, L2	REACTOR	X713	RELAY
LED 1~3	LED	X714	RELAY
LEV A~C	EXPANSION VALVE COIL	2152	2WAY VALVE SOLENOID COIL
MC	COMPRESSOR	2154	REVERSING VALVE SOLENOID COIL
MF	FAN MOTOR	26H	HEATER PROTECTOR
PTC1~3	CIRCUIT PROTECTION		

NOTES:
 1.About the indoor side electric wiring refer to the indoor unit electric wiring diagram for servicing.
 2.Use copper conductors only (For field wiring).
 3.Symbols below indicate.
 □ □ □ : Terminal block
 ○ ○ ○ : Connector

NOTES:
 1.À propos du câblage électrique de côté intérieur se référer à l'unité intérieure câblage schéma électrique pour l'entretien.
 2.Utiliser des conducteurs en cuivre (pour le câblage).
 3.Symbole ci-dessous indique.
 □ □ □ : Bornier
 ○ ○ ○ : Connecteur

MXZ-3C24NAHZ3 MXZ-3C30NAHZ3

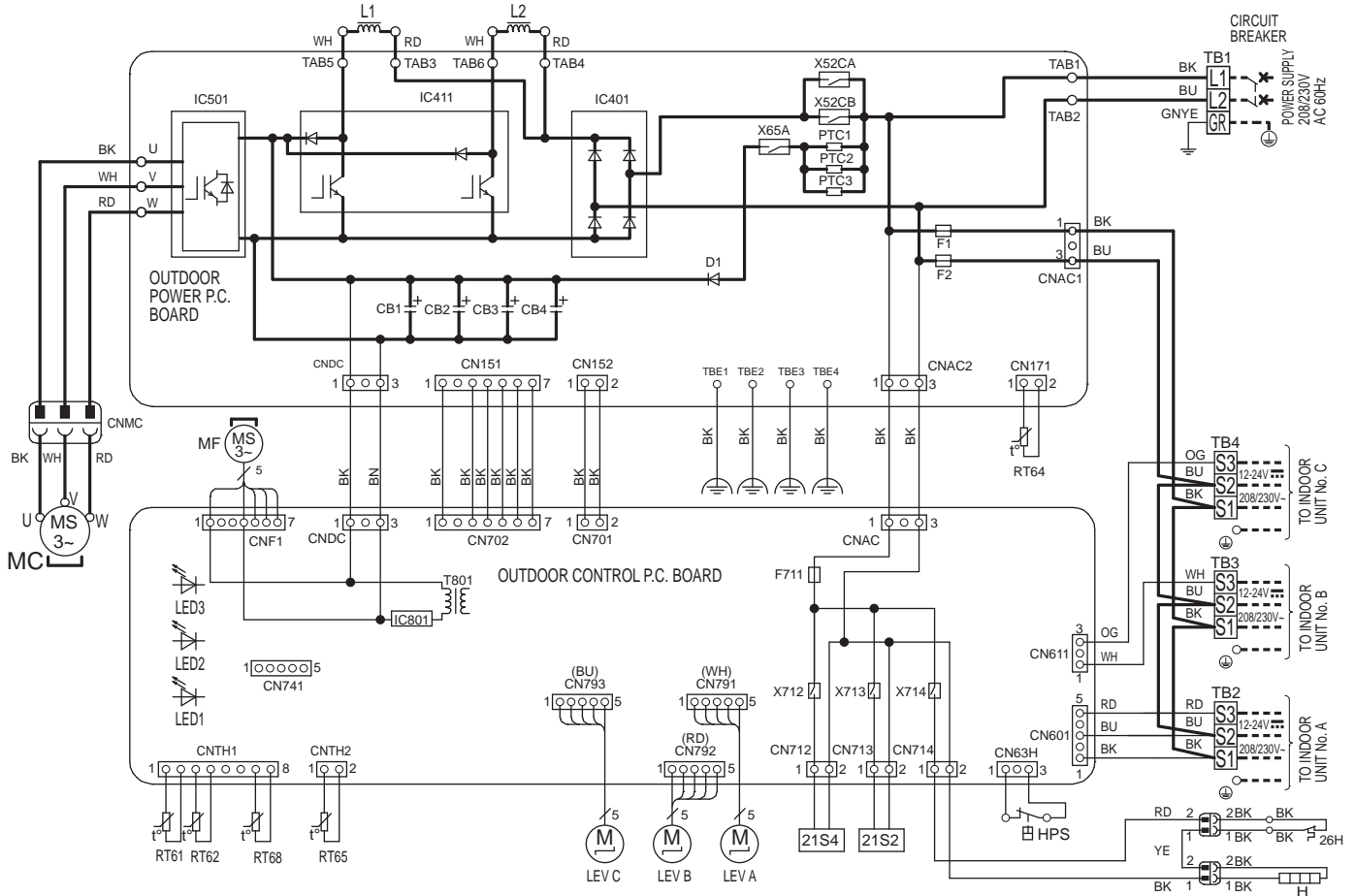

SYMBOL	NAME	SYMBOL	NAME
CB1-4	SMOOTHING CAPACITOR	RT61	DEFROST THERMISTOR
D1	DIODE	RT62	DISCHARGE TEMP. THERMISTOR
F1, F2	FUSE (T6.3AL 250V)	RT64	FIN TEMP. THERMISTOR
F711	FUSE (T3.15AL 250V)	RT65	AMBIENT TEMP. THERMISTOR
HPS	HIGH PRESSURE SWITCH	RT68	OUTDOOR HEAT EXCHANGER TEMP. THERMISTOR
H	DEFROST HEATER	T801	TRANSFORMER
IC401	DIODE BRIDGE	TB1-4	TERMINAL BLOCK
IC411	POWER MODULE	X52CA, B	RELAY
IC501	POWER MODULE	X65A	RELAY
IC801	POWER DEVICE	X712	RELAY
L1, L2	REACTOR	X713	RELAY
LED 1-3	LED	X714	RELAY
LEV-A-C	EXPANSION VALVE COIL	X714	RELAY
MC	COMPRESSOR	21S4	2WAY VALVE SOLENOID COIL
MF	FAN MOTOR	21S2	REVERSING VALVE SOLENOID COIL
PTC1-3	CIRCUIT PROTECTOR	26H	HEATER PROTECTOR

NOTES:
1. About the indoor side electric wiring refer to the indoor unit electric wiring diagram for the service.



2. Use copper conductors only (For field wiring).

3. Symbols below indicate.
 : Terminal block
 : Connector

NOTES:

1. À propos du câblage électrique de côté intérieur se référer à l'unité intérieure câblage schéma électrique pour l'entretien.

2. Utiliser des conducteurs en cuivre (pour le câblage).

3. Symbole ci-dessous indique.
 : Bornier
 : Connecteur

MXZ-3C24NAHZ4 MXZ-3C30NAHZ4

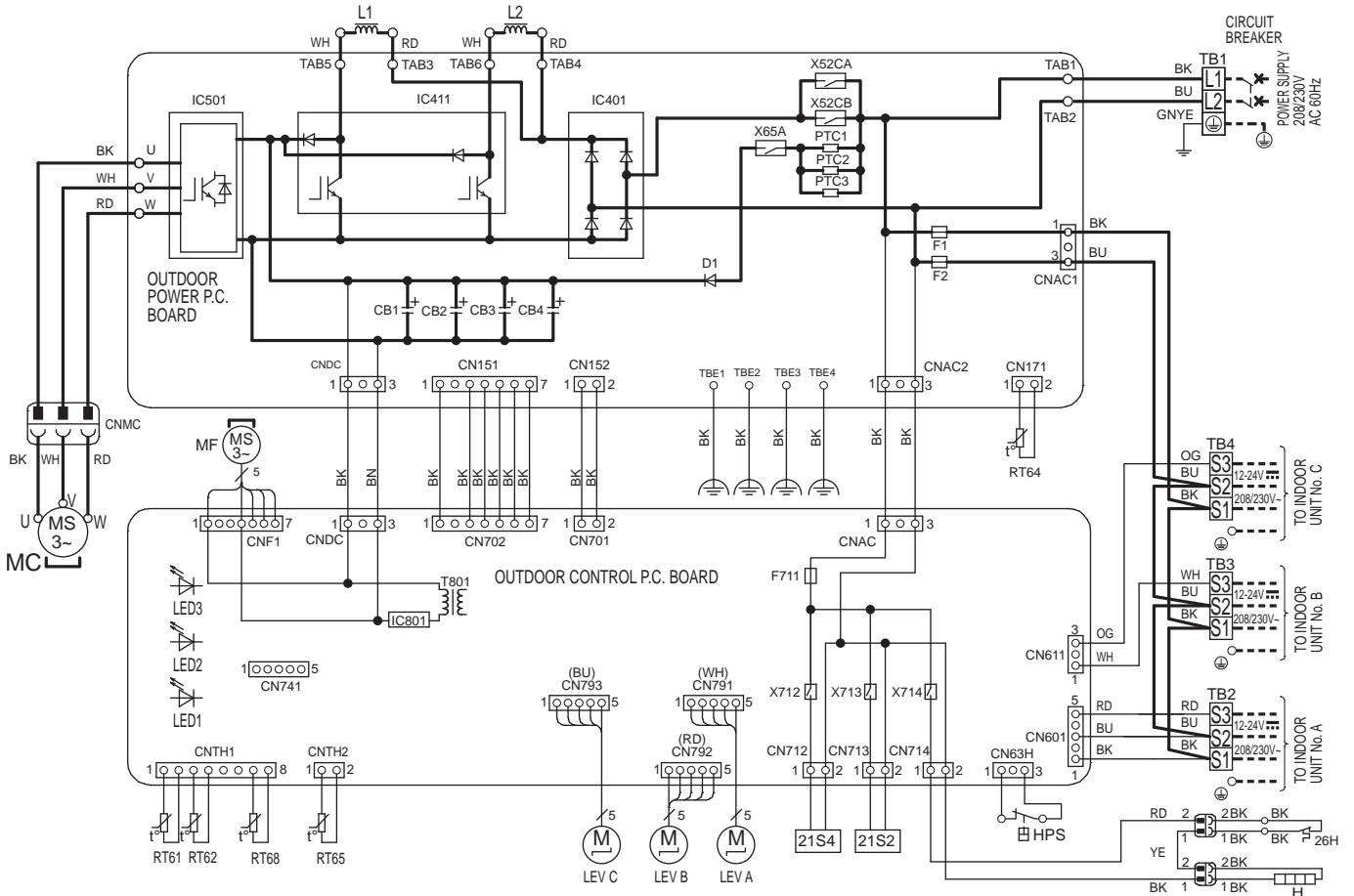

SYMBOL	NAME	SYMBOL	NAME
CB1-4	SMOOTHING CAPACITOR	RT61	DEFROST THERMISTOR
D1	DIODE	RT62	DISCHARGE TEMP. THERMISTOR
F1, F2	FUSE (T6.3AL 250V)	RT64	FIN TEMP. THERMISTOR
F711	FUSE (T3.15AL 250V)	RT65	AMBIENT TEMP. THERMISTOR
HPS	HIGH PRESSURE SWITCH	RT68	OUTDOOR HEAT EXCHANGER TEMP. THERMISTOR
H	DEFROST HEATER		
IC401	DIODE BRIDGE	T801	TRANSFORMER
IC411	POWER MODULE	TB1-4	TERMINAL BLOCK
IC501	POWER MODULE	X52CA, B	RELAY
IC801	POWER DEVICE	X65A	RELAY
L1, L2	REACTOR	X712	RELAY
LED 1-3	LED	X713	RELAY
LEV A-C	EXPANSION VALVE COIL	X714	RELAY
MC	COMPRESSOR	21S2	2-WAY VALVE SOLENOID COIL
MF	FAN MOTOR	21S4	4-WAY VALVE SOLENOID COIL
PTC1-3	CIRCUIT PROTECTOR	26H	HEATER PROTECTOR

NOTES:

- About the indoor side electric wiring refer to the indoor unit electric wiring diagram for the service.
- Use copper conductors only (For field wiring).
- Symbols below indicate.
 : Terminal block
 : Connector

NOTES:

- À propos du câblage électrique de côté intérieur se référer à l'unité intérieure câblage schéma électrique pour l'entretien.
- Utiliser des conducteurs en cuivre (pour le câblage).
- Symbole ci-dessous indique.
 : Bornier
 : Connecteur

MXZ-2C20NA2 MXZ-2C20NA3 MXZ-2C20NA4

Unit: inch (mm)

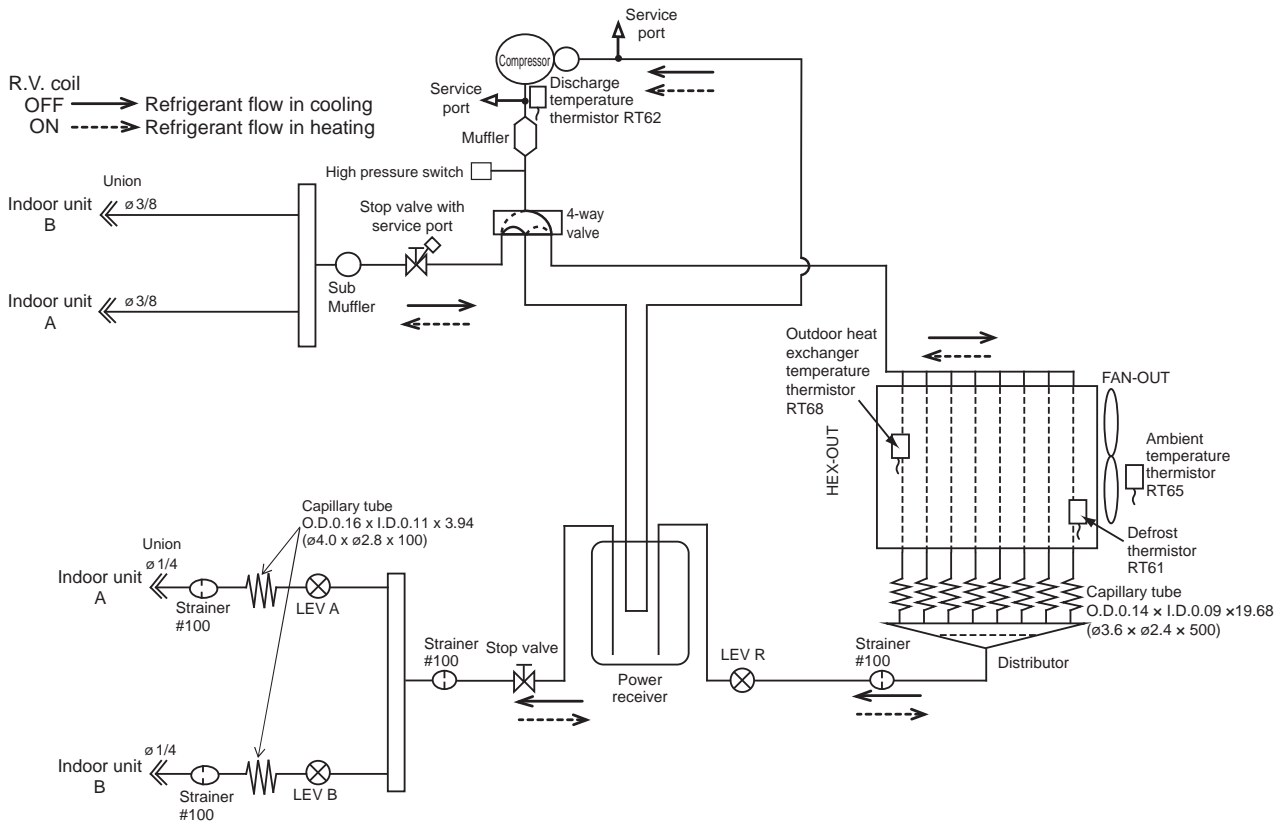

MXZ-2C20NA2 MXZ-2C20NA3 MXZ-2C20NA4

Operating Range

		Indoor intake air temperature	Outdoor intake air temperature
Cooling	Maximum	95°FDB, 71°FWB	115°FDB
	Minimum	67°FDB, 57°FWB	14°FDB
Heating	Maximum	80°FDB, 67°FWB	75°FDB, 65°FWB
	Minimum	70°FDB, 60°FWB	6°FDB, 5°FWB

MAX. REFRIGERANT PIPING LENGTH & PIPE SIZE SELECTION

Piping length each indoor unit (a, b)	82 ft. MAX.
Total piping length (a+b)	164 ft. MAX.
Bending point for each unit	25 MAX.
Total bending point	50 MAX.

*It is irrelevant which unit is higher.

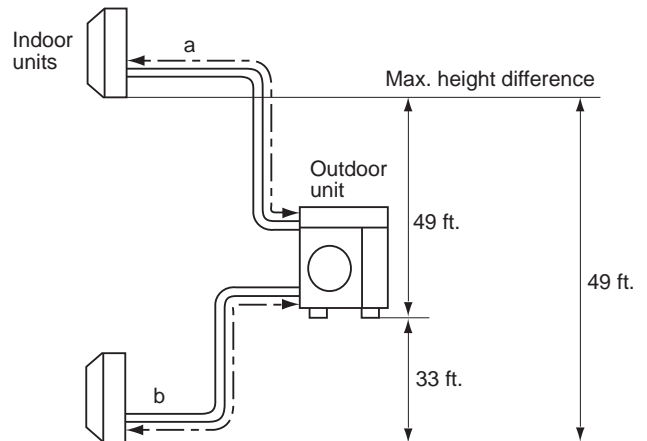

- Refrigerant pipe diameter is different according to indoor unit to be connected. When using extension pipes, refer to the tables below.
- When the diameter of refrigerant pipe is different from that of outdoor unit union, use optional Different-diameter pipe. For further information on Different-diameter pipe, refer to "PARTS CATALOG".

Unit: inch

Outdoor unit union diameter		
For		
Indoor unit A	Liquid	1/4
	Gas	3/8
Indoor unit B	Liquid	1/4
	Gas	3/8

MXZ-3C24NA MXZ-3C24NA2 MXZ-3C24NA3
MXZ-3C30NA MXZ-3C30NA2 MXZ-3C30NA3

Unit: inch (mm)

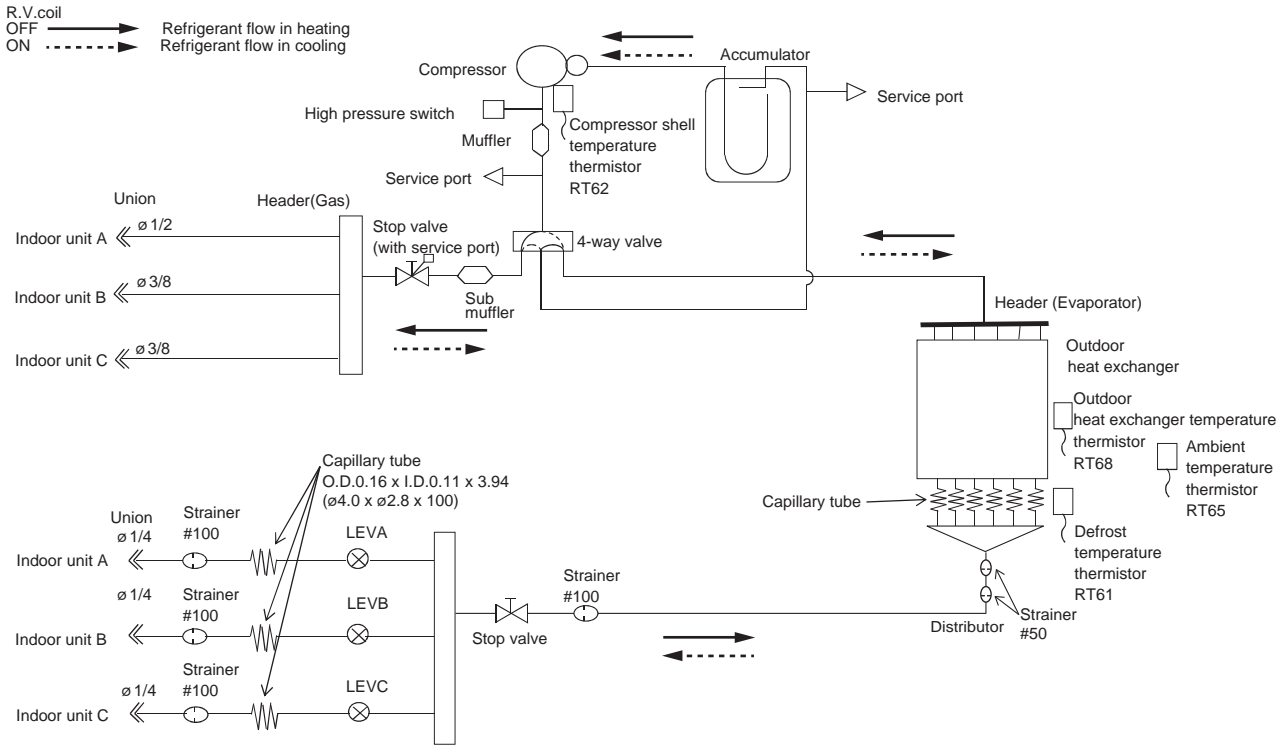

MXZ-3C24NA4
MXZ-3C30NA4

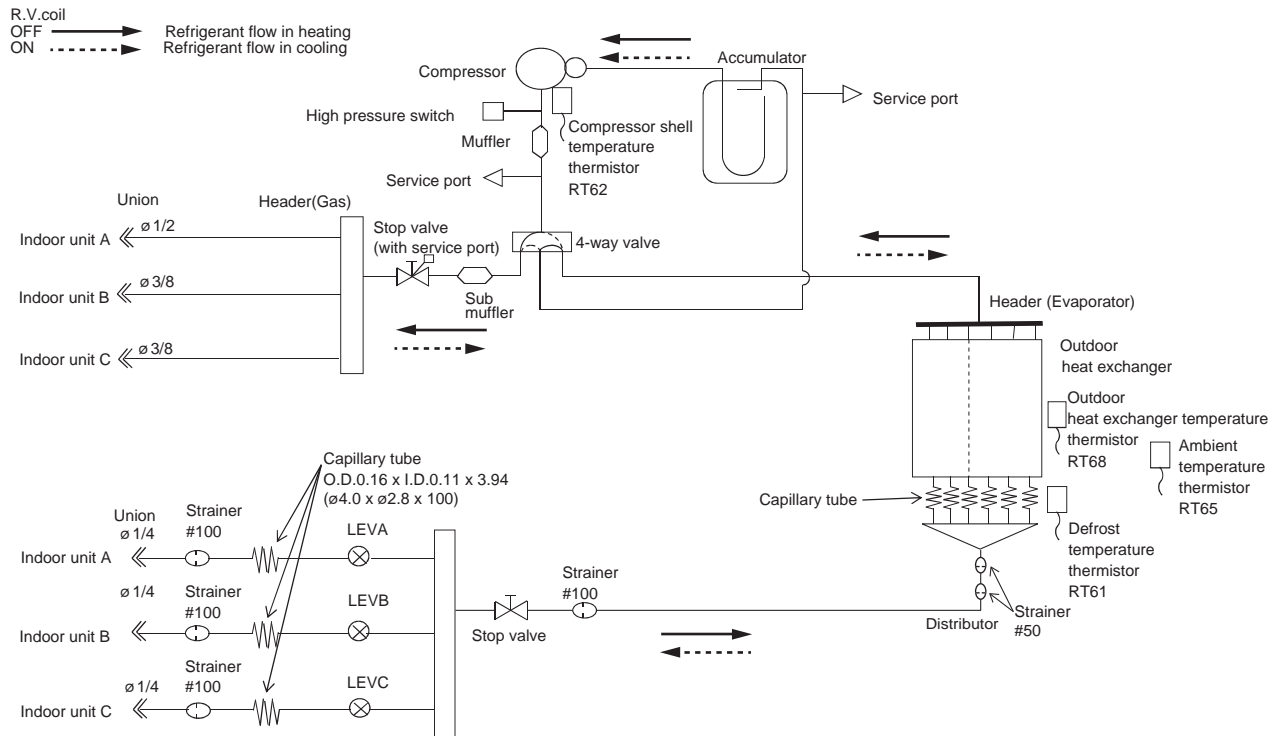

**MXZ-3C24NA MXZ-3C24NA2 MXZ-3C24NA3 MXZ-3C24NA4
MXZ-3C30NA MXZ-3C30NA2 MXZ-3C30NA3 MXZ-3C30NA4**

Operating Range

		Indoor intake air temperature	Outdoor intake air temperature
Cooling	Maximum	95°FDB, 71°FWB	115°FDB
	Minimum	67°FDB, 57°FWB	14°FDB
Heating	Maximum	80°FDB, 67°FWB	75°FDB, 65°FWB
	Minimum	70°FDB, 60°FWB	6°FDB, 5°FWB

MAX. REFRIGERANT PIPING LENGTH & PIPE SIZE SELECTION

Piping length each indoor unit (a, b, c)	82 ft. MAX.
Total piping length (a+b+c)	230 ft. MAX.
Bending point for each unit	25 MAX.
Total bending point	70 MAX.

*It is irrelevant which unit is higher.

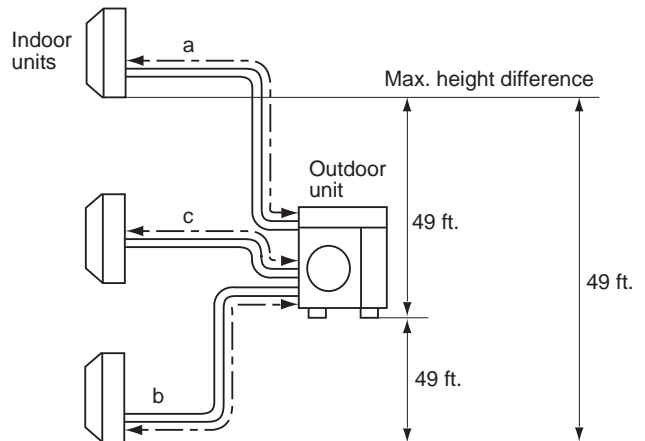

- Refrigerant pipe diameter is different according to indoor unit to be connected. When using extension pipes, refer to the tables below.
- When the diameter of refrigerant pipe is different from that of outdoor unit union, use optional Different-diameter pipe. For further information on Different-diameter pipe, refer to "PARTS CATALOG".

Unit: inch

Outdoor unit union diameter		
For		
Indoor unit A	Liquid	1/4
	Gas	1/2
Indoor unit B	Liquid	1/4
	Gas	3/8
Indoor unit C	Liquid	1/4
	Gas	3/8

MXZ-4C36NA MXZ-4C36NA2 MXZ-4C36NA3

Unit: inch (mm)

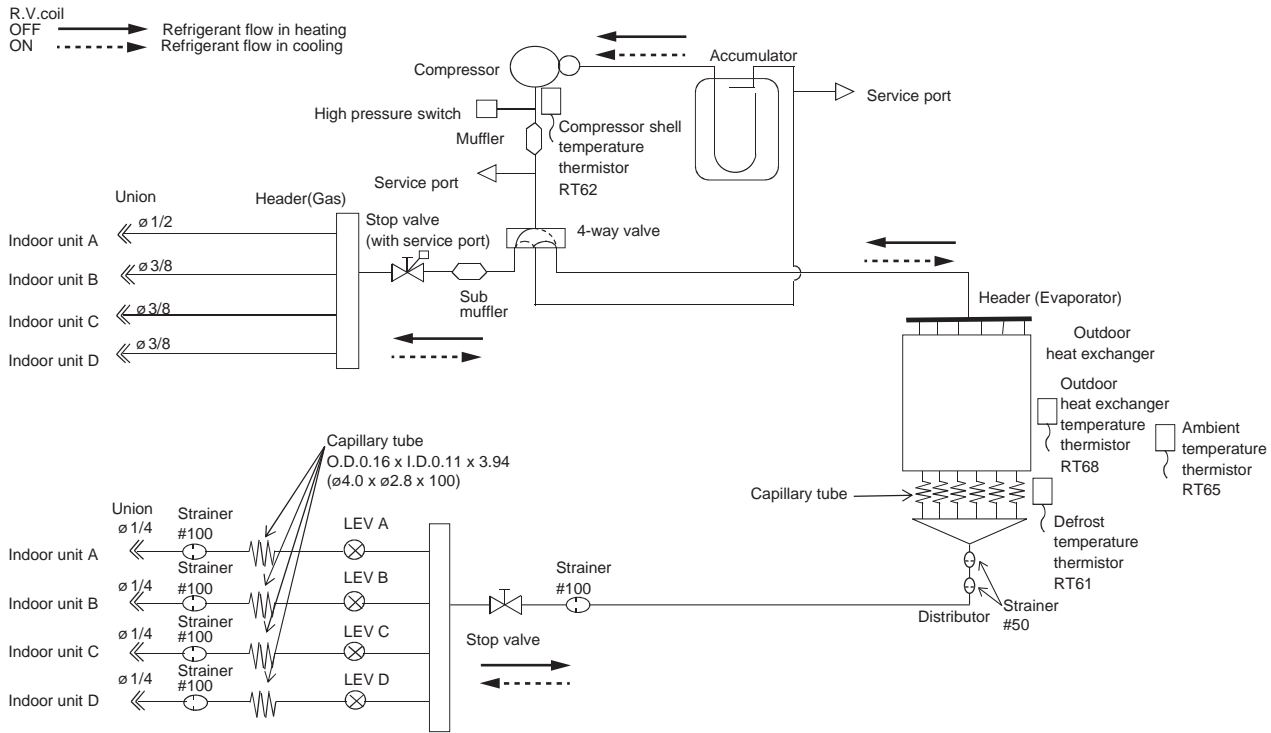

MXZ-4C36NA4

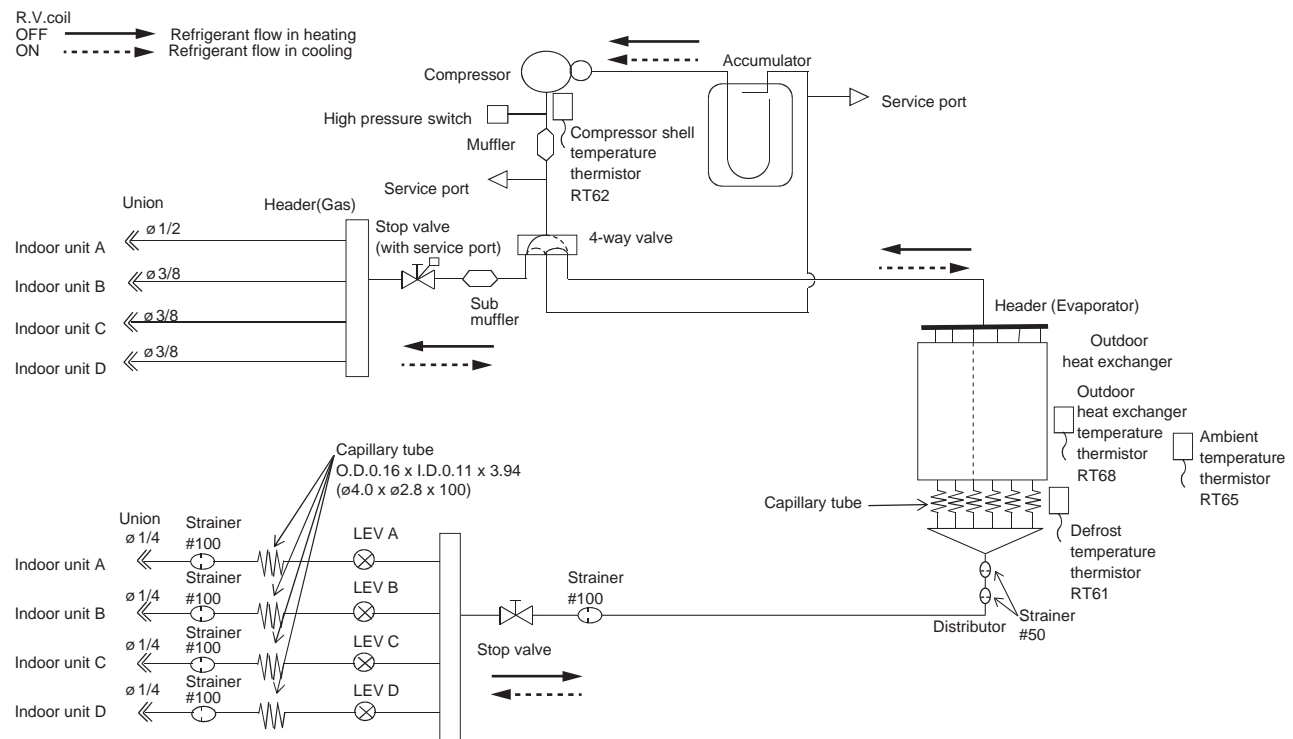

MXZ-4C36NA MXZ-4C36NA2 MXZ-4C36NA3 MXZ-4C36NA4

Operating Range

		Indoor intake air temperature	Outdoor intake air temperature
Cooling	Maximum	95°FDB, 71°FWB	115°FDB
	Minimum	67°FDB, 57°FWB	14°FDB
Heating	Maximum	80°FDB, 67°FWB	75°FDB, 65°FWB
	Minimum	70°FDB, 60°FWB	6°FDB, 5°FWB

MAX. REFRIGERANT PIPING LENGTH & PIPE SIZE SELECTION

Piping length each indoor unit (a, b, c, d)	82 ft. MAX.
Total piping length (a+b+c+d)	230 ft. MAX.
Bending point for each unit	25 MAX.
Total bending point	70 MAX.

*It is irrelevant which unit is higher.

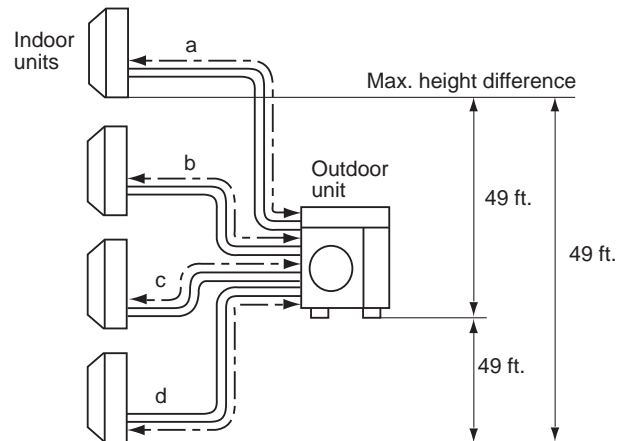

- Refrigerant pipe diameter is different according to indoor unit to be connected. When using extension pipes, refer to the tables below.
- When the diameter of refrigerant pipe is different from that of outdoor unit union, use optional Different-diameter pipe. For further information on Different-diameter pipe, refer to "PARTS CATALOG".

Unit: inch

Outdoor unit union diameter		
For		
Indoor unit A	Liquid	1/4
	Gas	1/2
Indoor unit B	Liquid	1/4
	Gas	3/8
Indoor unit C	Liquid	1/4
	Gas	3/8
Indoor unit D	Liquid	1/4
	Gas	3/8

MXZ-5C42NA

Unit: inch (mm)

R.V.coil
 OFF → Refrigerant flow in heating
 ON ····· Refrigerant flow in cooling

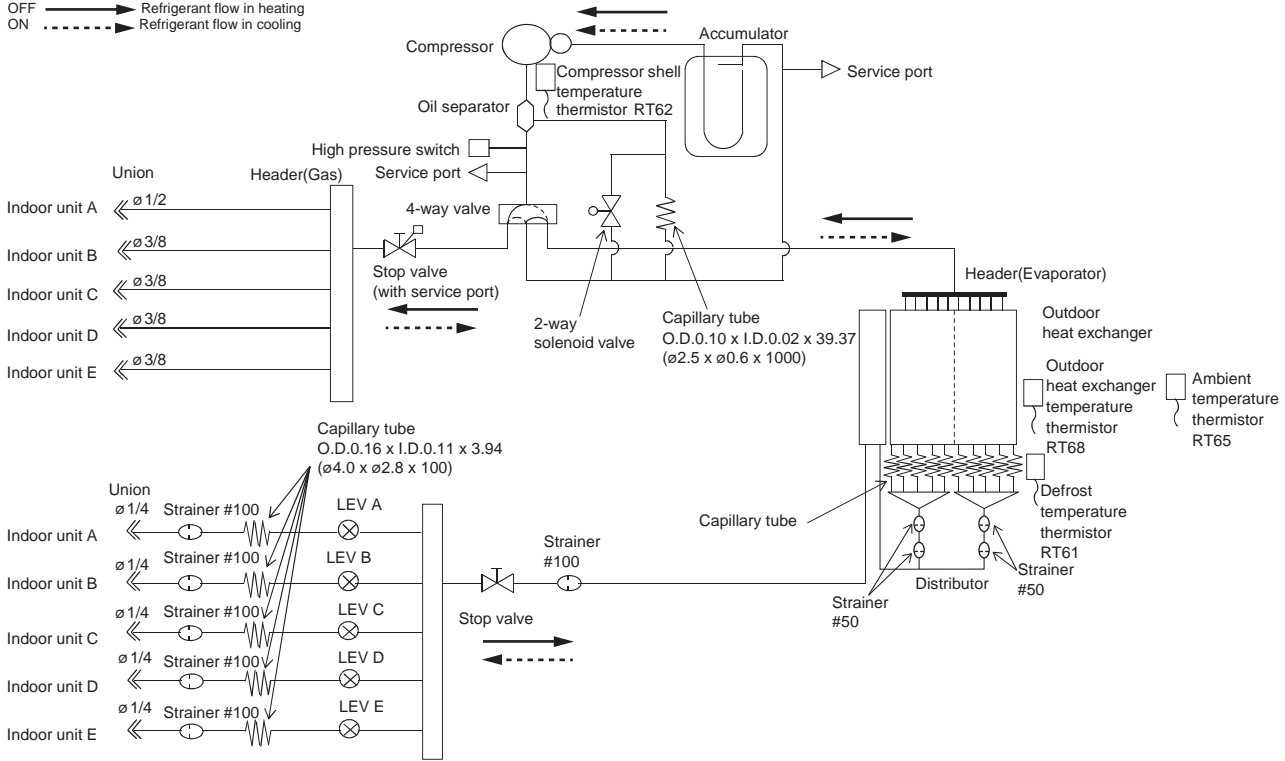

MXZ-5C42NA2 MXZ-5C42NA3 MXZ-5C42NA4

R.V.coil
 OFF → Refrigerant flow in heating
 ON ····· Refrigerant flow in cooling

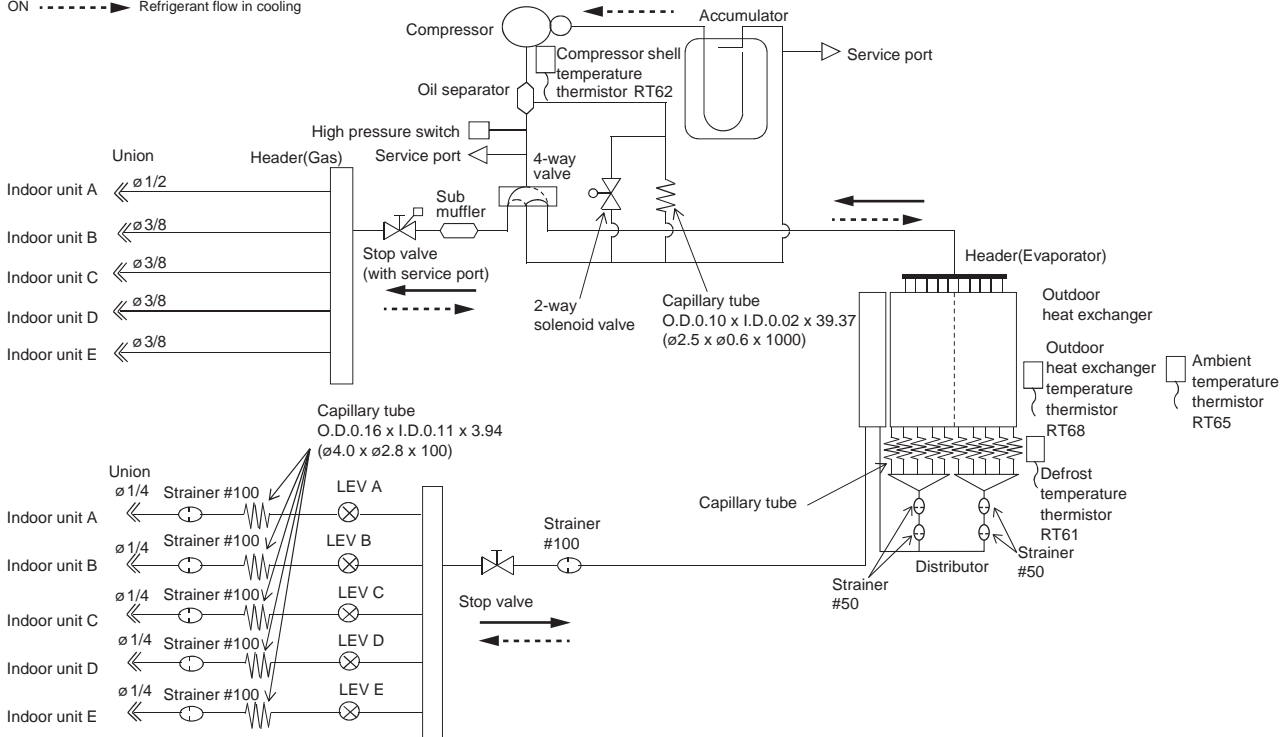

MXZ-5C42NA MXZ-5C42NA2 MXZ-5C42NA3 MXZ-5C42NA4

Operating Range

		Indoor intake air temperature	Outdoor intake air temperature
Cooling	Maximum	95°FDB, 71°FWB	115°FDB
	Minimum	67°FDB, 57°FWB	14°FDB
Heating	Maximum	80°FDB, 67°FWB	75°FDB, 65°FWB
	Minimum	70°FDB, 60°FWB	6°FDB, 5°FWB

MAX. REFRIGERANT PIPING LENGTH & PIPE SIZE SELECTION

Piping length each indoor unit (a, b, c, d, e)	82 ft. MAX.
Total piping length (a+b+c+d+e)	262 ft. MAX.
Bending point for each unit	25 MAX.
Total bending point	80 MAX.

*It is irrelevant which unit is higher.

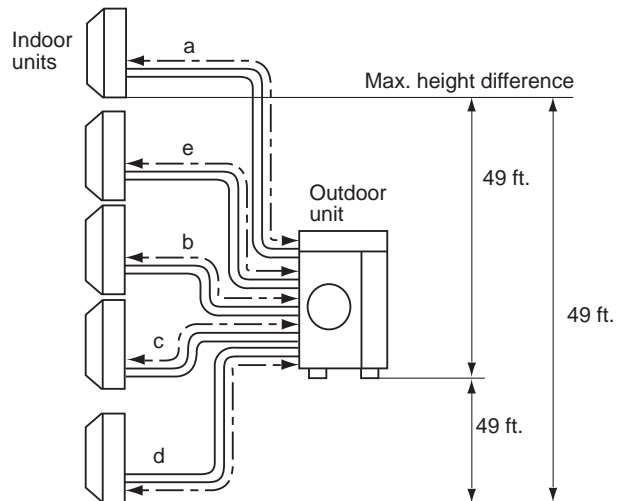

- Refrigerant pipe diameter is different according to indoor unit to be connected. When using extension pipes, refer to the tables below.
- When the diameter of refrigerant pipe is different from that of outdoor unit union, use optional Different-diameter pipe. For further information on Different-diameter pipe, refer to "PARTS CATALOG".

Unit: inch

Outdoor unit union diameter		
For		
Indoor unit A	Liquid	1/4
	Gas	1/2
Indoor unit B	Liquid	1/4
	Gas	3/8
Indoor unit C	Liquid	1/4
	Gas	3/8
Indoor unit D	Liquid	1/4
	Gas	3/8
Indoor unit E	Liquid	1/4
	Gas	3/8

MXZ-2C20NAHZ

Unit: inch (mm)

R.V.coil
 OFF → Refrigerant flow in heating
 ON ····· Refrigerant flow in cooling

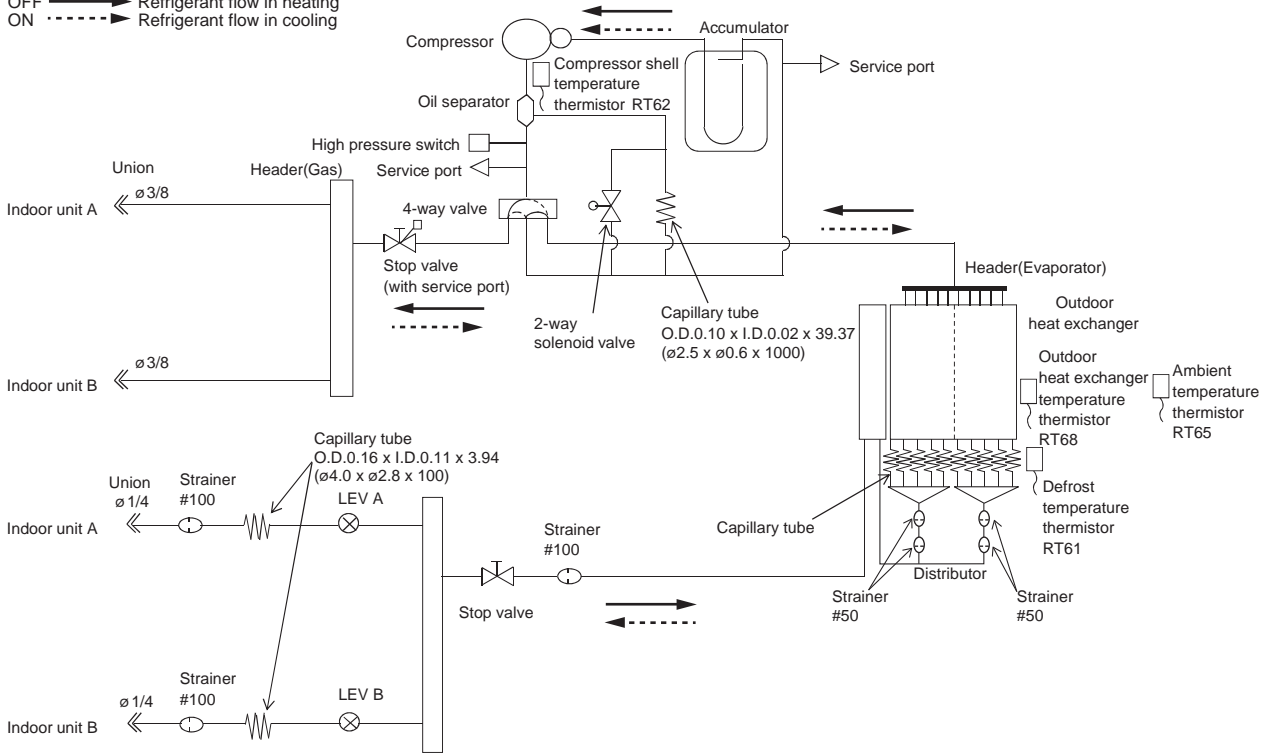

MXZ-2C20NAHZ2 MXZ-2C20NAHZ3 MXZ-2C20NAHZ4

R.V.coil
 OFF → Refrigerant flow in heating
 ON ····· Refrigerant flow in cooling

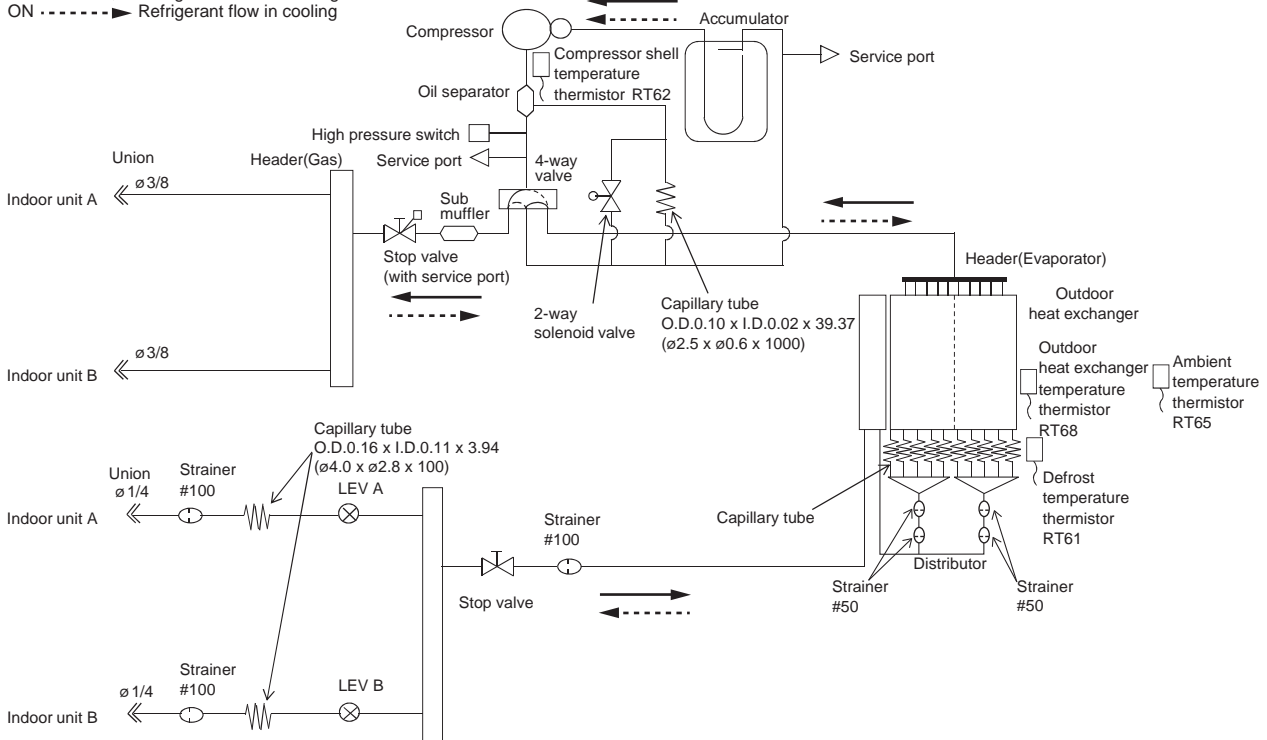

MXZ-2C20NAHZ MXZ-2C20NAHZ2 MXZ-2C20NAHZ3 MXZ-2C20NAHZ4

Operating Range

		Indoor intake air temperature	Outdoor intake air temperature
Cooling	Maximum	95°FDB, 71°FWB	115°FDB
	Minimum	67°FDB, 57°FWB	14°FDB
Heating	Maximum	80°FDB, 67°FWB	75°FDB, 65°FWB
	Minimum	70°FDB, 60°FWB	-12°FDB, -13°FWB

MAX. REFRIGERANT PIPING LENGTH & PIPE SIZE SELECTION

Piping length each indoor unit (a, b)	82 ft. MAX.
Total piping length (a+b)	164 ft. MAX.
Bending point for each unit	25 MAX.
Total bending point	50 MAX.

*It is irrelevant which unit is higher.

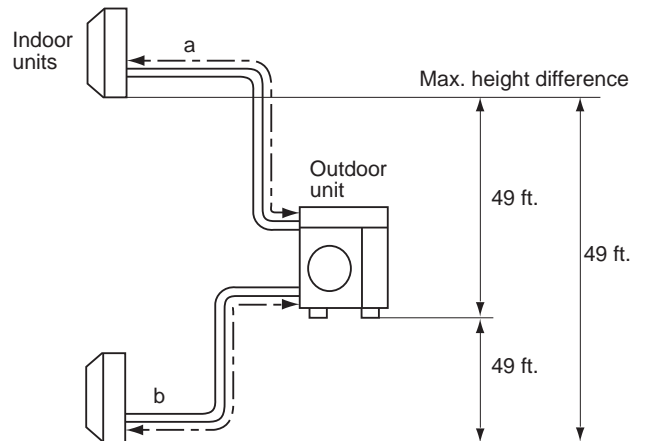

- Refrigerant pipe diameter is different according to indoor unit to be connected. When using extension pipes, refer to the tables below.
- When the diameter of refrigerant pipe is different from that of outdoor unit union, use optional Different-diameter pipe. For further information on Different-diameter pipe, refer to "PARTS CATALOG".

Unit: inch

Outdoor unit union diameter		
For		
Indoor unit A	Liquid	1/4
	Gas	3/8
Indoor unit B	Liquid	1/4
	Gas	3/8

MXZ-3C24NAHZ MXZ-3C30NAHZ

Unit: inch (mm)

R. V. coil
 OFF → Refrigerant flow in heating
 ON - - - - - Refrigerant flow in cooling

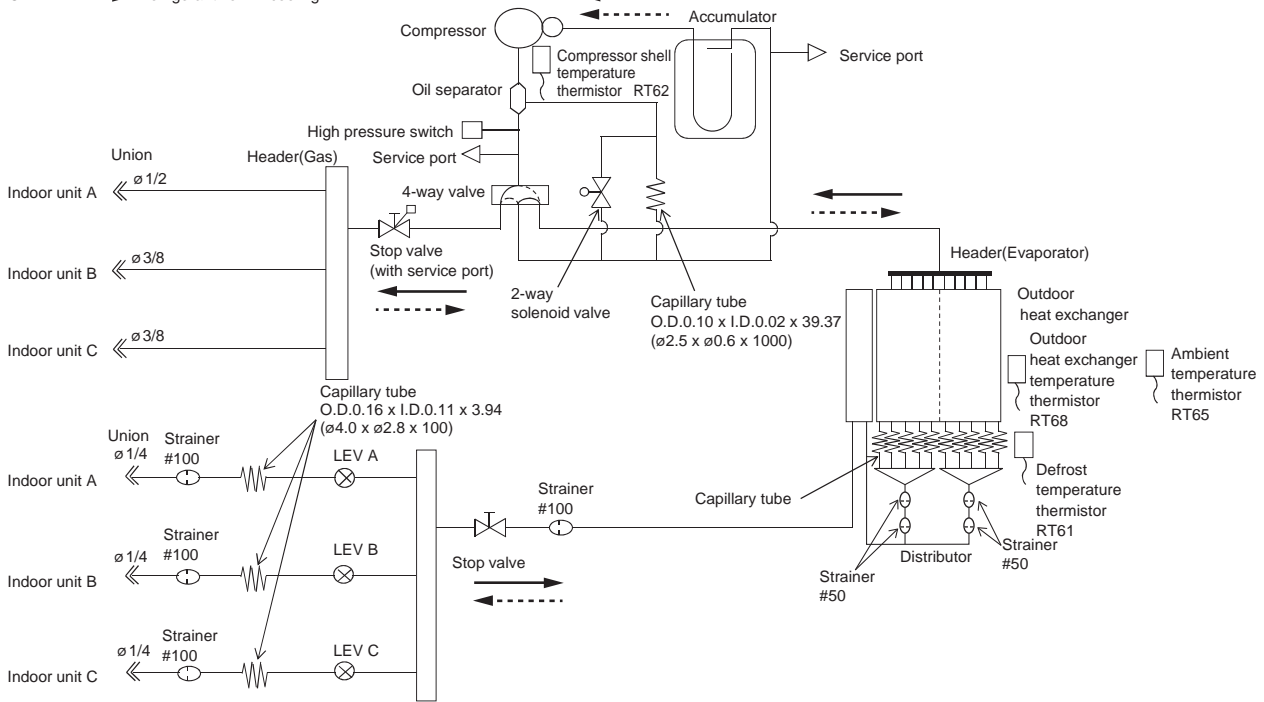

MXZ-3C24NAHZ2 MXZ-3C24NAHZ3 MXZ-3C24NAHZ4
MXZ-3C30NAHZ2 MXZ-3C30NAHZ3 MXZ-3C30NAHZ4

R. V. coil
 OFF → Refrigerant flow in heating
 ON - - - - - Refrigerant flow in cooling

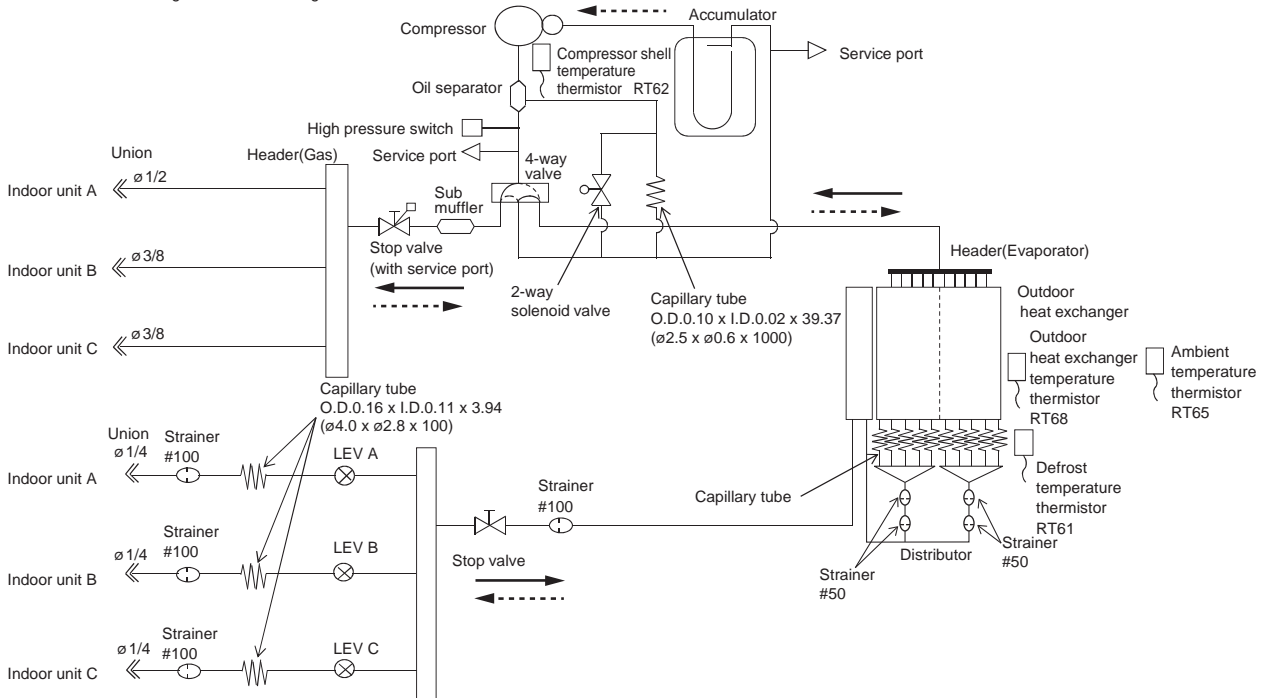

**MXZ-3C24NAHZ MXZ-3C24NAHZ2 MXZ-3C24NAHZ3 MXZ-3C24NAHZ4
 MXZ-3C30NAHZ MXZ-3C30NAHZ2 MXZ-3C30NAHZ3 MXZ-3C30NAHZ4**

Operating Range

		Indoor intake air temperature	Outdoor intake air temperature
Cooling	Maximum	95°FDB, 71°FWB	115°FDB
	Minimum	67°FDB, 57°FWB	14°FDB
Heating	Maximum	80°FDB, 67°FWB	75°FDB, 65°FWB
	Minimum	70°FDB, 60°FWB	-12°FDB, -13°FWB

MAX. REFRIGERANT PIPING LENGTH & PIPE SIZE SELECTION

Piping length each indoor unit (a, b, c)	82 ft. MAX.
Total piping length (a+b+c)	230 ft. MAX.
Bending point for each unit	25 MAX.
Total bending point	70 MAX.

*It is irrelevant which unit is higher.

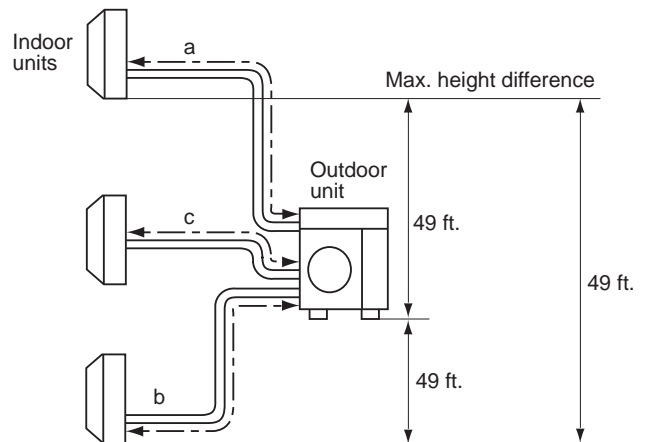

- Refrigerant pipe diameter is different according to indoor unit to be connected. When using extension pipes, refer to the tables below.
- When the diameter of refrigerant pipe is different from that of outdoor unit union, use optional Different-diameter pipe. For further information on Different-diameter pipe, refer to "PARTS CATALOG".

Unit: inch

Outdoor unit union diameter		
For		
Indoor unit A	Liquid	1/4
	Gas	1/2
Indoor unit B	Liquid	1/4
	Gas	3/8
Indoor unit C	Liquid	1/4
	Gas	3/8

PUMPING DOWN

When relocating or disposing of the air conditioner, pump down the system following the procedure below so that no refrigerant is released into the atmosphere.

- 1) Turn off the breaker.
- 2) Connect the gauge manifold valve to the service port of the stop valve on the gas pipe side of the outdoor unit.
- 3) Fully close the stop valve on the liquid pipe side of the outdoor unit.
- 4) Turn on the breaker.
- 5) Start the emergency COOL operation on all the indoor units.
- 6) When the pressure gauge shows 0.1 to 0 psi [Gauge] (0.05 to 0 MPa), fully close the stop valve on the gas pipe side of the outdoor unit and stop the operation. (Refer to the indoor unit installation manual about the method for stopping the operation.)
 - * If too much refrigerant has been added to the air conditioner system, the pressure may not drop to 0.1 to 0 psi [Gauge] (0.05 to 0 MPa), or the protection function may operate due to the pressure increase in the high pressure refrigerant circuit. If this occurs, use a refrigerant collecting device to collect all of the refrigerant in the system, and then recharge the system with the correct amount of refrigerant after the indoor and outdoor units have been relocated.
- 7) Turn off the breaker. Remove the pressure gauge and the refrigerant piping.

WARNING

When pumping down the refrigerant, stop the compressor before disconnecting the refrigerant pipes. The compressor may burst and cause injury if any foreign substance, such as air, enters the pipes.

Model				MXZ-2C20NA2 MXZ-2C20NA3 MXZ-2C20NA4			
Indoor type				Non-Duct (09+09)		Duct (09+12)	
Item		Unit		Cooling	Heating	Cooling	Heating
Total	Capacity	Btu/h		18,000	22,000	20,000	22,000
	SHF	-		-	-	-	-
	Input	kW		1.417	1.641	2.000	1.771
Electrical circuit	Power supply (V, phase, Hz)			208/230, 1, 60			
	Input	kW		1.373	1.597	1.880	1.691
	Comp. current (208/230V)	A		6.82 / 6.17	8.03 / 7.26	9.61 / 8.69	8.55 / 7.73
	Fan motor current	A		0.2	0.2	0.2	0.2
Refrigerant circuit	Condensing pressure	PSIG		396	328	419	351
	Suction pressure	PSIG		146	94	130	100
	Discharge temperature	°F		174	165	170	168
	Condensing temperature	°F		116	100	160	101
	Suction temperature	°F		74	47	55	49
	Comp. shell bottom temp.	°F		173	163	160	157
	Ref. pipe length [Total pipe length for multi-system]	ft		82 [164]			
	Refrigerant charge (R410A)	-		5 lb. 15 oz.			
Outdoor unit	Intake air temperature	DB	°F	95	47	95	47
		WB	°F	-	43	-	43
	Fan speed	rpm		650	700	650	700
	Airflow	CFM		1,342	1,458	1,342	1,458

Model				MXZ-3C24NA MXZ-3C24NA2 MXZ-3C24NA3			
Indoor type				Non-Duct (06+06+09)		Duct (09+09+09)	
Item		Unit		Cooling	Heating	Cooling	Heating
Total	Capacity	Btu/h		22,000	25,000	23,600	24,600
	SHF	-		-	-	-	-
	Input	kW		1.62	1.75	2.10	1.90
Electrical circuit	Power supply (V, phase, Hz)			208/230, 1, 60			
	Input	kW		1.554	1.684	1.920	1.780
	Comp. current (208/230V)	A		7.47 / 6.76	8.1 / 7.32	9.23 / 8.35	8.56 / 7.74
	Fan motor current	A		0.3	0.3	0.3	0.3
Refrigerant circuit	Condensing pressure	PSIG		395	310	419	345
	Suction pressure	PSIG		162	101	138	102
	Discharge temperature	°F		143	137	155	141
	Condensing temperature	°F		116	98	120	106
	Suction temperature	°F		59	36	50	34
	Comp. shell bottom temp.	°F		137	128	146	131
	Ref. pipe length [Total pipe length for multi-system]	ft		82 [230]			
	Refrigerant charge (R410A)	-		6lb. 13 oz.			
Outdoor unit	Intake air temperature	DB	°F	95	47	95	47
		WB	°F	-	43	-	43
	Fan speed	rpm		720	750	720	750
	Airflow	CFM		2,287	2,382	2,287	2,382

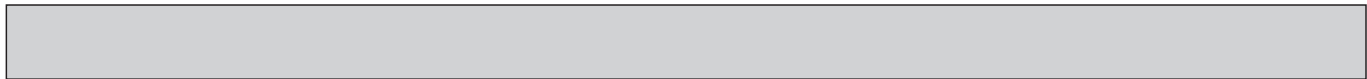

Model			MXZ-3C24NA4				
Indoor type			Non-Duct (06+06+09)		Duct (09+09+09)		
Item	Unit		Cooling	Heating	Cooling	Heating	
Total	Capacity	Btu/h	22,000	25,000	23,600	24,600	
	SHF	–	–	–	–	–	
	Input	kW	1.61	1.74	2.10	1.89	
Electrical circuit	Power supply (V, phase, Hz)		208/230, 1, 60				
	Input	kW	1.554	1.684	1.920	1.780	
	Comp. current (208/230V)	A	7.47 / 6.76	8.1 / 7.32	9.23 / 8.35	8.56 / 7.74	
	Fan motor current	A	0.3	0.3	0.3	0.3	
Refrigerant circuit	Condensing pressure	PSIG	407	317	419	345	
	Suction pressure	PSIG	161	98	138	102	
	Discharge temperature	°F	147	140	155	141	
	Condensing temperature	°F	116	110	120	106	
	Suction temperature	°F	59	34	50	34	
	Comp. shell bottom temp.	°F	141	131	146	131	
	Ref. pipe length [Total pipe length for multi-system]	ft	82 [230]				
	Refrigerant charge (R410A)	–	6lb. 13 oz.				
Outdoor unit	Intake air temperature	DB	°F	95	47	95	47
		WB	°F	–	43	–	43
	Fan speed	rpm	650	680	650	680	
	Airflow	CFM	2,133	2,243	2,133	2,243	

Model			MXZ-3C30NA MXZ-3C30NA2 MXZ-3C30NA3				
Indoor type			Non-Duct (09+09+12)		Duct (09+09+12)		
Item	Unit		Cooling	Heating	Cooling	Heating	
Total	Capacity	Btu/h	28,400	28,600	27,400	27,600	
	SHF	–	–	–	–	–	
	Input	kW	2.68	2.15	2.84	2.22	
Electrical circuit	Power supply (V, phase, Hz)		208/230, 1, 60				
	Input	kW	2.614	2.084	2.650	2.090	
	Comp. current (208/230V)	A	12.57 / 11.37	10.02 / 9.06	12.74 / 11.52	10.05 / 9.09	
	Fan motor current	A	0.3	0.3	0.3	0.3	
Refrigerant circuit	Condensing pressure	PSIG	432	323	439	323	
	Suction pressure	PSIG	137	97	132	99	
	Discharge temperature	°F	159	136	165	136	
	Condensing temperature	°F	122	101	124	101	
	Suction temperature	°F	49	32	47	32	
	Comp. shell bottom temp.	°F	145	121	156	128	
	Ref. pipe length [Total pipe length for multi-system]	ft	82 [230]				
	Refrigerant charge (R410A)	–	6 lb.13 oz.				
Outdoor unit	Intake air temperature	DB	°F	95	47	95	47
		WB	°F	–	43	–	43
	Fan speed	rpm	720	750	720	750	
	Airflow	CFM	2,287	2,382	2,287	2,382	



Model			MXZ-3C30NA4				
Indoor type			Non-Duct (09+09+12)		Duct (09+09+12)		
Item		Unit	Cooling	Heating	Cooling	Heating	
Total	Capacity	Btu/h	28,400	28,600	27,400	27,600	
	SHF	–	–	–	–	–	
	Input	kW	2.67	2.149	2.84	2.22	
Electrical circuit	Power supply (V, phase, Hz)		208/230, 1, 60				
	Input	kW	2.614	2.084	2.650	2.090	
	Comp. current (208/230V)	A	12.57 / 11.37	10.02 / 9.06	12.74 / 11.52	10.05 / 9.09	
	Fan motor current	A	0.3	0.3	0.3	0.3	
Refrigerant circuit	Condensing pressure	PSIG	440	323	440	323	
	Suction pressure	PSIG	142	94	130	99	
	Discharge temperature	°F	161	139	160	136	
	Condensing temperature	°F	121	101	119	101	
	Suction temperature	°F	52	30	52	32	
	Comp. shell bottom temp.	°F	147	124	151	128	
	Ref. pipe length [Total pipe length for multi-system]	ft	82 [230]				
	Refrigerant charge (R410A)	–	6 lb.13 oz.				
Outdoor unit	Intake air temperature	DB	°F	95	47	95	47
		WB	°F	–	43	–	43
	Fan speed	rpm	650	680	650	680	
	Airflow	CFM	2,133	2,243	2,133	2,243	

Model			MXZ-4C36NA MXZ-4C36NA2 MXZ-4C36NA3				
Indoor type			Non-Duct (09+09+09+09)		Duct (09+09+09+09)		
Item		Unit	Cooling	Heating	Cooling	Heating	
Total	Capacity	Btu/h	35,400	36,000	34,400	34,400	
	SHF	–	–	–	–	–	
	Input	kW	3.76	3.02	3.94	3.10	
Electrical circuit	Power supply (V, phase, Hz)		208/230, 1, 60				
	Input	kW	3.672	2.932	3.700	2.940	
	Comp. current (208/230V)	A	17.65 / 15.97	14.1 / 12.75	17.79 / 16.09	14.13 / 12.78	
	Fan motor current	A	0.3	0.3	0.3	0.3	
Refrigerant circuit	Condensing pressure	PSIG	461	297	470	334	
	Suction pressure	PSIG	141	89	129	91	
	Discharge temperature	°F	172	138	176	147	
	Condensing temperature	°F	127	95	129	103	
	Suction temperature	°F	51	28	46	29	
	Comp. shell bottom temp.	°F	162	130	165	139	
	Ref. pipe length [Total pipe length for multi-system]	ft	82 [230]				
	Refrigerant charge (R410A)	–	6 lb.13 oz.				
Outdoor unit	Intake air temperature	DB	°F	95	47	95	47
		WB	°F	–	43	–	43
	Fan speed	rpm	720	750	720	750	
	Airflow	CFM	2,287	2,382	2,287	2,382	



Model			MXZ-4C36NA4				
Indoor type			Non-Duct (09+09+09+09)		Duct (09+09+09+09)		
Item	Unit		Cooling	Heating	Cooling	Heating	
Total	Capacity	Btu/h	35,400	36,000	34,400	34,400	
	SHF	–	–	–	–	–	
	Input	kW	3.76	3.01	3.94	3.09	
Electrical circuit	Power supply (V, phase, Hz)		208/230, 1, 60				
	Input	kW	3.672	2.932	3.700	2.940	
	Comp. current (208/230V)	A	17.65 / 15.97	14.1 / 12.75	17.79 / 16.09	14.13 / 12.78	
	Fan motor current	A	0.3	0.3	0.3	0.3	
Refrigerant circuit	Condensing pressure	PSIG	479	297	470	334	
	Suction pressure	PSIG	143	86	129	91	
	Discharge temperature	°F	175	140	176	147	
	Condensing temperature	°F	128	95	129	103	
	Suction temperature	°F	51	26	46	29	
	Comp. shell bottom temp.	°F	165	132	165	139	
	Ref. pipe length [Total pipe length for multi-system]	ft	82 [230]				
	Refrigerant charge (R410A)	–	6 lb.13 oz.				
Outdoor unit	Intake air temperature	DB	°F	95	47	95	47
		WB	°F	–	43	–	43
	Fan speed	rpm	650	680	650	680	
	Airflow	CFM	2,133	2,243	2,133	2,243	

Model			MXZ-5C42NA MXZ-5C42NA2 MXZ-5C42NA3 MXZ-5C42NA4				
Indoor type			Non-Duct (06+09+09+09+09)		Duct (09+09+09+09+09)		
Item	Unit		Cooling	Heating	Cooling	Heating	
Total	Capacity	Btu/h	40,500	45,000	37,500	41,000	
	SHF	–	–	–	–	–	
	Input	kW	4.41	3.58	4.12	3.47	
Electrical circuit	Power supply (V, phase, Hz)		208/230, 1, 60				
	Input	kW	4.300	3.465	3.870	3.270	
	Comp. current (208/230V)	A	20.67 / 18.7	16.66 / 15.07	18.61 / 16.83	15.72 / 14.22	
	Fan motor current	A	0.43 / 0.39	0.43 / 0.39	0.43 / 0.39	0.43 / 0.39	
Refrigerant circuit	Condensing pressure	PSIG	466	305	446	326	
	Suction pressure	PSIG	153	93	137	98	
	Discharge temperature	°F	172	155	165	143	
	Condensing temperature	°F	127	97	124	102	
	Suction temperature	°F	53	27	47	29	
	Comp. shell bottom temp.	°F	156	138	145	121	
	Ref. pipe length [Total pipe length for multi-system]	ft	82 [262]				
	Refrigerant charge (R410A)	–	8 lb. 13 oz.				
Outdoor unit	Intake air temperature	DB	°F	95	47	95	47
		WB	°F	–	43	–	43
	Fan speed	rpm	630	730	630	730	
	Airflow	CFM	2,118	2,542	2,118	2,542	



Model				MXZ-2C20NAHZ	MXZ-2C20NAHZ2	MXZ-2C20NAHZ3	MXZ-2C20NAHZ4
Indoor type				Non-Duct (09+09)		Duct (09+12)	
Item		Unit		Cooling	Heating	Cooling	Heating
Total	Capacity	Btu/h		18,000	22,000	20,000	22,000
	SHF	-		-	-	-	-
	Input	kW		1.34	1.62	1.82	1.75
Electrical circuit	Power supply (V, phase, Hz)			208/230, 1, 60			
	Input	kW		1.296	1.574	1.670	1.660
	Comp. current (208/230V)		A	6.23 / 5.63	7.57 / 6.84	8.03 / 7.26	7.98 / 7.22
	Fan motor current		A	0.43 / 0.39	0.43 / 0.39	0.43 / 0.39	0.43 / 0.39
Refrigerant circuit	Condensing pressure		PSIG	406	341	406	334
	Suction pressure		PSIG	154	110	133	113
	Discharge temperature		°F	158	131	148	141
	Condensing temperature		°F	108	105	112	103
	Suction temperature		°F	60	37	46	37
	Comp. shell bottom temp.		°F	137	107	127	117
	Ref. pipe length [Total pipe length for multi-system]		ft	82 [164]			
	Refrigerant charge (R410A)		-	8 lb. 13 oz.			
Outdoor unit	Intake air temperature	DB	°F	95	47	95	47
		WB	°F	-	43	-	43
	Fan speed		rpm	630	730	630	730
	Airflow		CFM	2,118	2,542	2,118	2,542

Model				MXZ-3C24NAHZ	MXZ-3C24NAHZ2	MXZ-3C24NAHZ3	MXZ-3C24NAHZ4
Indoor type				Non-Duct (06+06+09)		Duct (09+09+09)	
Item		Unit		Cooling	Heating	Cooling	Heating
Total	Capacity	Btu/h		22,000	25,000	23,600	24,600
	SHF	-		-	-	-	-
	Input	kW		1.63	1.73	2.36	1.88
Electrical circuit	Power supply (V, phase, Hz)			208/230, 1, 60			
	Input	kW		1.564	1.661	2.180	1.760
	Comp. current (208/230V)		A	7.52 / 6.8	7.99 / 7.22	10.48 / 9.48	8.46 / 7.65
	Fan motor current		A	0.43 / 0.39	0.43 / 0.39	0.43 / 0.39	0.43 / 0.39
Refrigerant circuit	Condensing pressure		PSIG	397	302	377	329
	Suction pressure		PSIG	164	106	136	109
	Discharge temperature		°F	144	122	152	127
	Condensing temperature		°F	114	97	115	103
	Suction temperature		°F	59	42	48	36
	Comp. shell bottom temp.		°F	128	105	136	109
	Ref. pipe length [Total pipe length for multi-system]		ft	82 [230]			
	Refrigerant charge (R410A)		-	8 lb. 13 oz.			
Outdoor unit	Intake air temperature	DB	°F	95	47	95	47
		WB	°F	-	43	-	43
	Fan speed		rpm	630	730	630	730
	Airflow		CFM	2,118	2,542	2,118	2,542

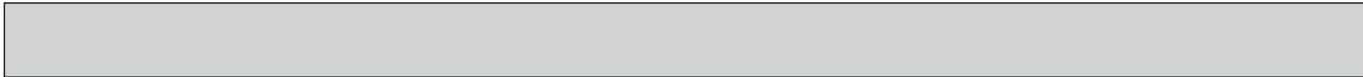

Model			MXZ-3C30NAHZ	MXZ-3C30NAHZ2	MXZ-3C30NAHZ3	MXZ-3C30NAHZ4	
Indoor type			Non-Duct (09+09+12)		Duct (09+09+12)		
Item		Unit	Cooling	Heating	Cooling	Heating	
Total	Capacity	Btu/h	28,400	28,600	27,400	27,600	
	SHF	–	–	–	–	–	
	Input	kW	2.28	2.10	2.67	2.19	
Electrical circuit	Power supply (V, phase, Hz)		208/230, 1, 60				
	Input	kW	2.214	2.031	2.480	2.060	
	Comp. current (208/230V)		A	10.64 / 9.63	9.76 / 8.83	11.92 / 10.78	9.9 / 8.96
	Fan motor current		A	0.43 / 0.39	0.43 / 0.39	0.43 / 0.39	0.43 / 0.39
Refrigerant circuit	Condensing pressure		PSIG	404	321	416	329
	Suction pressure		PSIG	146	103	131	107
	Discharge temperature		°F	146	131	153	128
	Condensing temperature		°F	117	101	118	103
	Suction temperature		°F	52	35	45	35
	Comp. shell bottom temp.		°F	129	111	135	108
	Ref. pipe length [Total pipe length for multi-system]		ft	82 [230]			
	Refrigerant charge (R410A)		–	8 lb. 13 oz.			
Outdoor unit	Intake air temperature	DB	°F	95	47	95	47
		WB	°F	–	43	–	43
	Fan speed		rpm	650	730	630	730
	Airflow		CFM	2,224	2,542	2,118	2,542

9-1. OPERATING RANGE

(1) POWER SUPPLY

	Model		Rating	Guaranteed Voltage
Outdoor unit	MXZ-2C20NA2	MXZ-2C20NAHZ	208/230 V 60 Hz 1ø	Min. 198 V 208 V 230 V Max. 253 V
	MXZ-2C20NA3	MXZ-2C20NAHZ2		
	MXZ-2C20NA4	MXZ-2C20NAHZ3		
	MXZ-3C24NA	MXZ-2C20NAHZ4		
	MXZ-3C24NA2	MXZ-3C24NAHZ		
	MXZ-3C24NA3	MXZ-3C24NAHZ2		
	MXZ-3C24NA4	MXZ-3C24NAHZ3		
	MXZ-3C30NA	MXZ-3C24NAHZ4		
	MXZ-3C30NA2	MXZ-3C30NAHZ		
	MXZ-3C30NA3	MXZ-3C30NAHZ2		
	MXZ-3C30NA4	MXZ-3C30NAHZ3		
	MXZ-4C36NA	MXZ-3C30NAHZ4		
	MXZ-4C36NA2			
	MXZ-4C36NA3			
	MXZ-4C36NA4			
	MXZ-5C42NA			
	MXZ-5C42NA2			
	MXZ-5C42NA3			
	MXZ-5C42NA4			

(2) OPERATION

Function	Intake air temperature Condition	Indoor		Outdoor	
		DB (°F)	WB (°F)	DB (°F)	WB (°F)
Cooling	"A" Cooling steady state at rated compressor speed	80	67	95	(75)
	"B-2" Cooling steady state at rated compressor speed	80	67	82	(65)
	"B-1" Cooling steady state at minimum compressor speed	80	67	82	(65)
	Low ambient cooling steady state at minimum compressor speed	80	67	67	(53.5)
	Intermediate cooling steady state at intermediate compressor speed	80	67	87	(69)
Heating	Standard rating-heating at rated compressor speed	70	60	47	43
	Low temperature heating at rated compressor speed	70	60	17	15
	Max. temperature heating at minimum compressor speed	70	60	62	56.5
	High temperature heating at minimum compressor speed	70	60	47	43
	Frost accumulation at rated compressor speed	70	60	35	33
	Frost accumulation at intermediate compressor speed	70	60	35	33

MXZ-3C24NA	MXZ-3C30NA	MXZ-4C36NA	MXZ-5C42NA	
MXZ-2C20NA2	MXZ-3C24NA2	MXZ-3C30NA2	MXZ-4C36NA2	MXZ-5C42NA2
MXZ-2C20NA3	MXZ-3C24NA3	MXZ-3C30NA3	MXZ-4C36NA3	MXZ-5C42NA3
MXZ-2C20NA4	MXZ-3C24NA4	MXZ-3C30NA4	MXZ-4C36NA4	MXZ-5C42NA4
MXZ-2C20NAHZ	MXZ-3C24NAHZ	MXZ-3C30NAHZ		
MXZ-2C20NAHZ2	MXZ-3C24NAHZ2	MXZ-3C30NAHZ2		
MXZ-2C20NAHZ3	MXZ-3C24NAHZ3	MXZ-3C30NAHZ3		
MXZ-2C20NAHZ4	MXZ-3C24NAHZ4	MXZ-3C30NAHZ4		

The standard specifications apply only to the operation of the air conditioner under normal conditions.

Since operating conditions vary according to the areas where these units are installed, the following information has been provided to clarify the operating characteristics of the air conditioner under the conditions indicated by the performance curve.

(1) GUARANTEED VOLTAGE

198 ~ 253 V 60 Hz

(2) AIR FLOW

Air flow should be set at MAX.

(3) MAIN READINGS

- | | | |
|---|------|-----------|
| (1) Indoor intake air wet-bulb temperature : | °FWB | } Cooling |
| (2) Indoor outlet air wet-bulb temperature : | °FWB | |
| (3) Outdoor intake air dry-bulb temperature : | °FDB | |
| (4) Total input: | W | } Heating |
| (5) Indoor intake air dry-bulb temperature : | °FDB | |
| (6) Outdoor intake air wet-bulb temperature : | °FWB | |
| (7) Total input : | W | |

Indoor air wet and dry bulb temperature difference on the left side of the following chart shows the difference between the indoor intake air wet and dry bulb temperature and the indoor outlet air wet and dry bulb temperature for your reference at service.

How to measure the indoor air wet and dry bulb temperature difference

1. Attach at least 2 sets of wet and dry bulb thermometers to the indoor air intake as shown in the figure, and at least 2 sets of wet and dry bulb thermometers to the indoor air outlet. The thermometers must be attached to the position where air speed is high.
2. Attach at least 2 sets of wet and dry bulb thermometers to the outdoor air intake. Cover the thermometers to prevent direct rays of the sun.
3. Check that the air filter is cleaned.
4. Open windows and doors of room.
5. Press the EMERGENCY OPERATION switch once (twice) to start the EMERGENCY COOL (HEAT) MODE.
6. Compressor starts running at 33 Hz (COOL) or 45 Hz (HEAT). The frequency at each operation mode is fixed.
7. When system stabilizes after more than 15 minutes, measure temperature and take an average temperature.
8. 10 minutes later, measure temperature again and check that the temperature does not change.

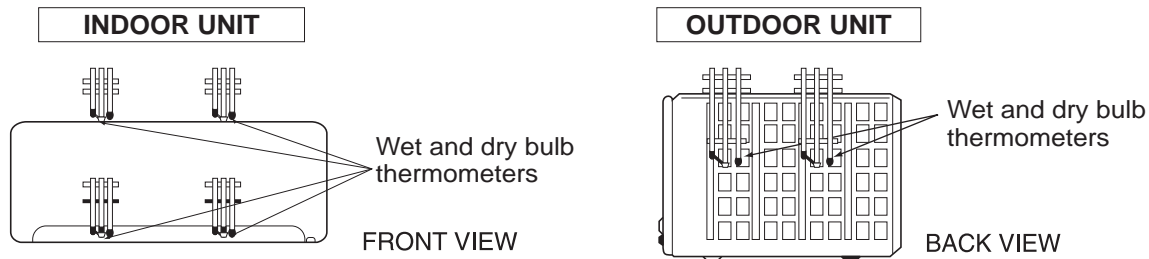

9-2. CAPACITY AND THE INPUT CURVES MXZ-2C20NA2 MXZ-2C20NA3 MXZ-2C20NA4

Indoor air Wet-bulb temperature difference (°F)	06 class	09 class	12 class	15 class
6.8		9.6	11.7	11.4
6.2		8.8	10.7	10.5
5.7		8.0	9.7	9.5
5.1		7.2	8.7	8.5
4.6		6.5	7.8	7.6
4.1		5.8	6.9	6.7
3.6		5.1	6.0	5.8

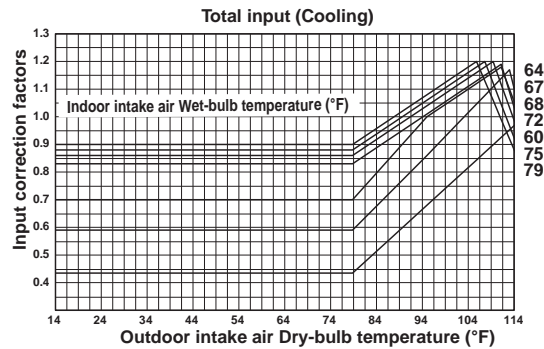
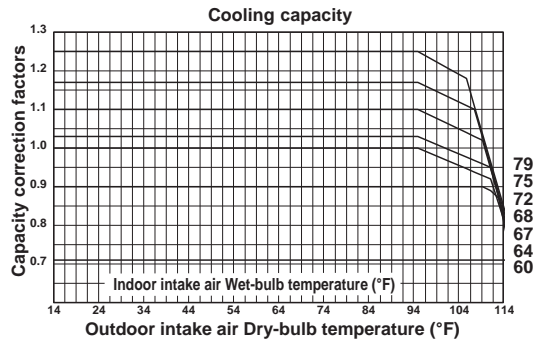

Indoor air Wet-bulb temperature difference (°F)	06 class	09 class	12 class	15 class
26.1		36.7	48.2	52.8
24.3		34.0	44.8	49.1
22.5		31.3	41.4	45.4
20.5		28.8	38.0	41.6
18.5		25.7	34.0	37.4
16.6		23.2	30.6	33.7
14.8		20.7	27.2	29.9
13.0		18.0	24.1	26.5
11.0		15.3	20.2	22.1
9.2		13.0	17.1	18.7
7.4		10.3	13.5	14.8

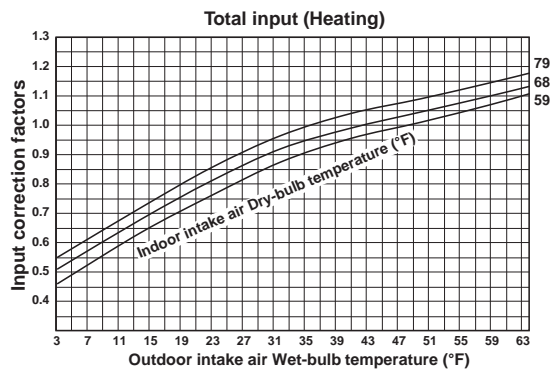
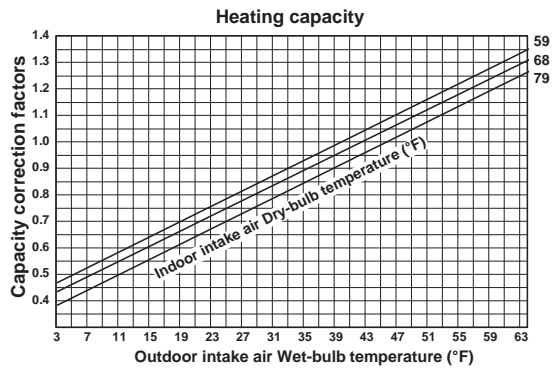

MXZ-3C24NA MXZ-3C24NA2 MXZ-3C24NA3 MXZ-3C24NA4
MXZ-3C30NA MXZ-3C30NA2 MXZ-3C30NA3 MXZ-3C30NA4
MXZ-4C36NA MXZ-4C36NA2 MXZ-4C36NA3 MXZ-4C36NA4

Indoor air Wet-bulb temperature difference (°F)	06 class	09 class	12 class	15 class	18 class	24 class
6.8	9.6	11.7	11.4	14.5	13.2	
6.2	8.8	10.7	10.5	13.2	12.1	
5.7	8.0	9.7	9.5	12.0	10.9	
5.1	7.2	8.7	8.5	10.7	9.8	
4.6	6.5	7.8	7.6	9.5	8.7	
4.1	5.8	6.9	6.7	8.3	7.6	
3.6	5.1	6.0	5.8	7.1	6.5	

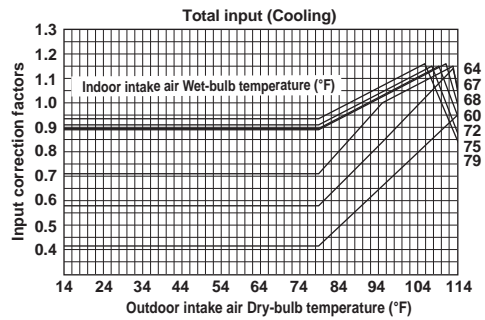
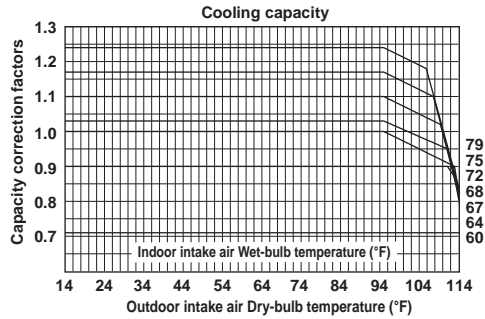

Indoor air Wet-bulb temperature difference (°F)	06 class	09 class	12 class	15 class	18 class	24 class
26.1	36.7	48.2	52.8	56.5	42.9	
24.3	34.0	44.8	49.1	52.8	39.8	
22.5	31.3	41.4	45.4	49.1	36.7	
20.5	28.8	38.0	41.6	45.2	33.7	
18.5	25.7	34.0	37.4	40.5	30.2	
16.6	23.2	30.6	33.7	36.5	27.2	
14.8	20.7	27.2	29.9	32.4	24.1	
13.0	18.0	24.1	26.5	29.0	21.4	
11.0	15.3	20.2	22.1	24.1	18.0	
9.2	13.0	17.1	18.7	20.5	15.1	
7.4	10.3	13.5	14.8	16.0	11.9	

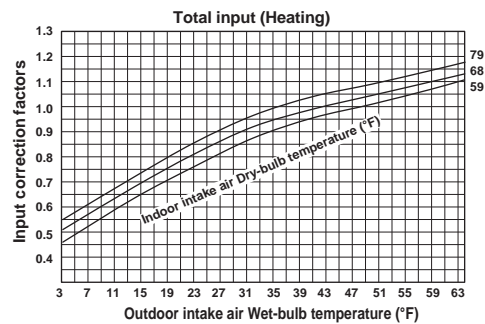
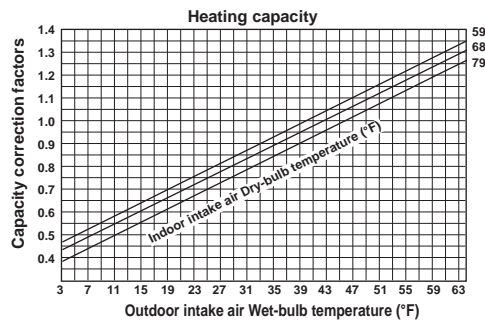

MXZ-5C42NA

MXZ-5C42NA2

MXZ-5C42NA3

MXZ-5C42NA4

6.8	9.6	11.7	11.4	14.5	13.2
6.2	8.8	10.7	10.5	13.2	12.1
5.7	8.0	9.7	9.5	12.0	10.9
5.1	7.2	8.7	8.5	10.7	9.8
4.6	6.5	7.8	7.6	9.5	8.7
4.1	5.8	6.9	6.7	8.3	7.6
3.6	5.1	6.0	5.8	7.1	6.5
06 class	09 class	12 class	15 class	18 class	24 class

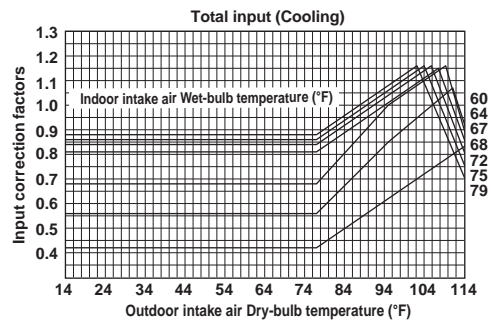
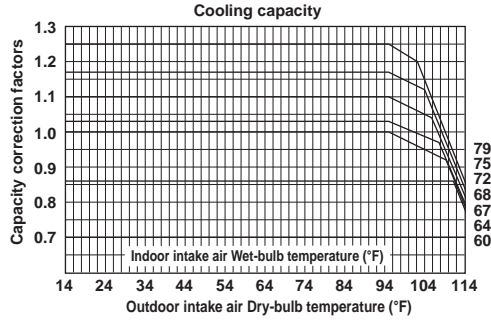

26.1	36.7	48.2	52.8	56.5	42.9
24.3	34.0	44.8	49.1	52.8	39.8
22.5	31.3	41.4	45.4	49.1	36.7
20.5	28.8	38.0	41.6	45.2	33.7
18.5	25.7	34.0	37.4	40.5	30.2
16.6	23.2	30.6	33.7	36.5	27.2
14.8	20.7	27.2	29.9	32.4	24.1
13.0	18.0	24.1	26.5	29.0	21.4
11.0	15.3	20.2	22.1	24.1	18.0
9.2	13.0	17.1	18.7	20.5	15.1
7.4	10.3	13.5	14.8	16.0	11.9
06 class	09 class	12 class	15 class	18 class	24 class

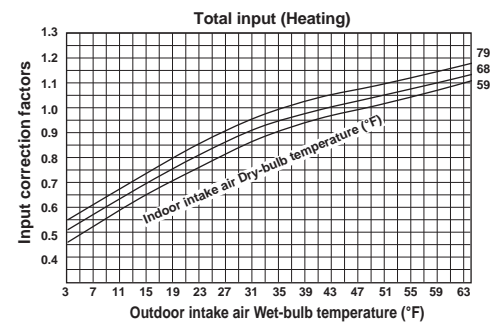
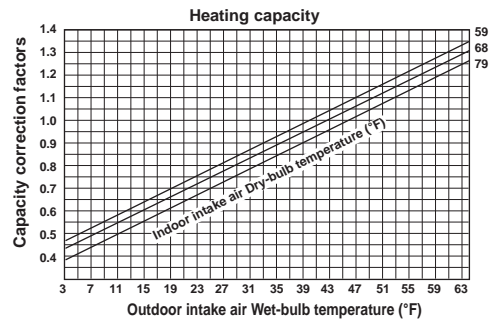

MXZ-2C20NAHZ MXZ-2C20NAHZ2 MXZ-2C20NAHZ3 MXZ-2C20NAHZ4
MXZ-3C24NAHZ MXZ-3C24NAHZ2 MXZ-3C24NAHZ3 MXZ-3C24NAHZ4
MXZ-3C30NAHZ MXZ-3C30NAHZ2 MXZ-3C30NAHZ3 MXZ-3C30NAHZ4

Indoor air Wet-bulb temperature difference (°F)	06 class	09 class	12 class	15 class	18 class	24 class
6.8		9.6	11.7	11.4	14.5	13.2
6.2		8.8	10.7	10.5	13.2	12.1
5.7		8.0	9.7	9.5	12.0	10.9
5.1		7.2	8.7	8.5	10.7	9.8
4.6		6.5	7.8	7.6	9.5	8.7
4.1		5.8	6.9	6.7	8.3	7.6
3.6		5.1	6.0	5.8	7.1	6.5

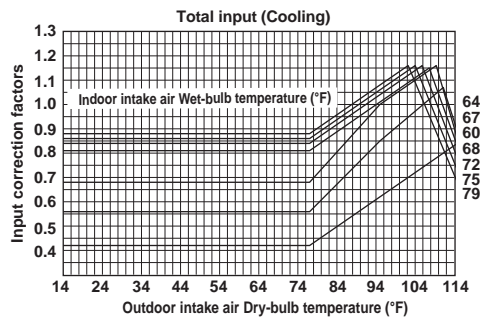
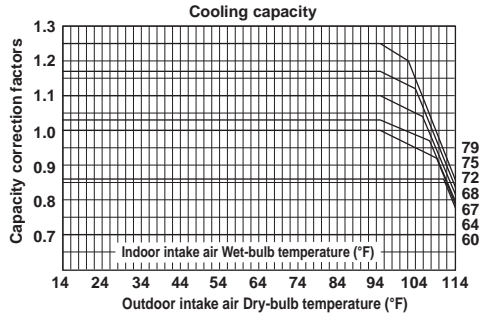

Indoor air Wet-bulb temperature difference (°F)	06 class	09 class	12 class	15 class	18 class	24 class
26.1		36.7	48.2	52.8	56.5	42.9
24.3		34.0	44.8	49.1	52.8	39.8
22.5		31.3	41.4	45.4	49.1	36.7
20.5		28.8	38.0	41.6	45.2	33.7
18.5		25.7	34.0	37.4	40.5	30.2
16.6		23.2	30.6	33.7	36.5	27.2
14.8		20.7	27.2	29.9	32.4	24.1
13.0		18.0	24.1	26.5	29.0	21.4
11.0		15.3	20.2	22.1	24.1	18.0
9.2		13.0	17.1	18.7	20.5	15.1

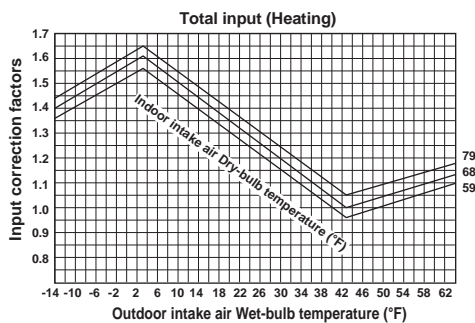
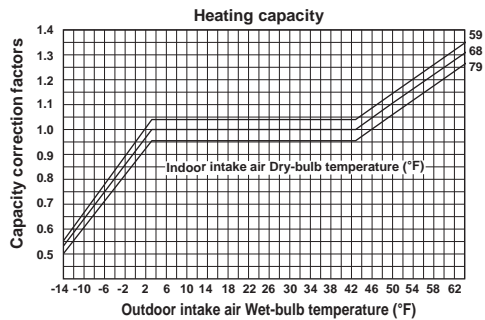

9-3. CAPACITY AND INPUT CORRECTION BY MEANS OF INVERTER OUTPUT FREQUENCY (OUTDOOR UNIT: MXZ-2C20NA2 MXZ-2C20NA3 MXZ-2C20NA4)

1. 06-class unit in single operation

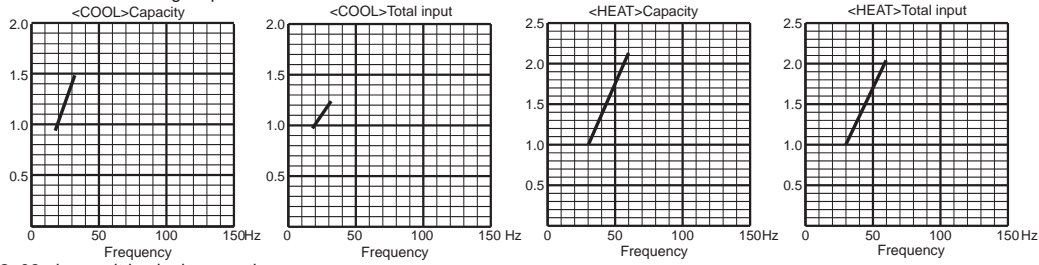

2. 09-class unit in single operation

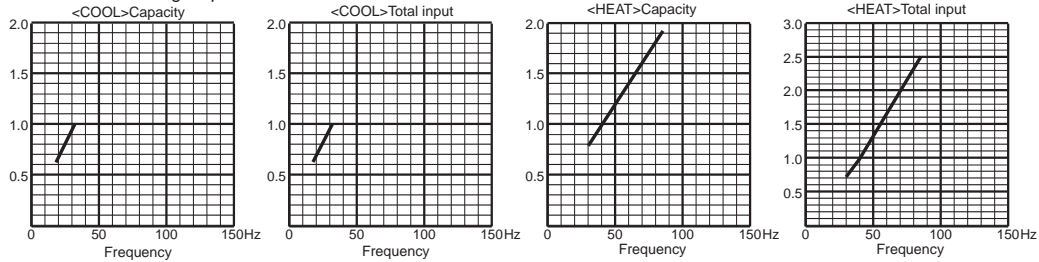

3. 12-class unit in single operation

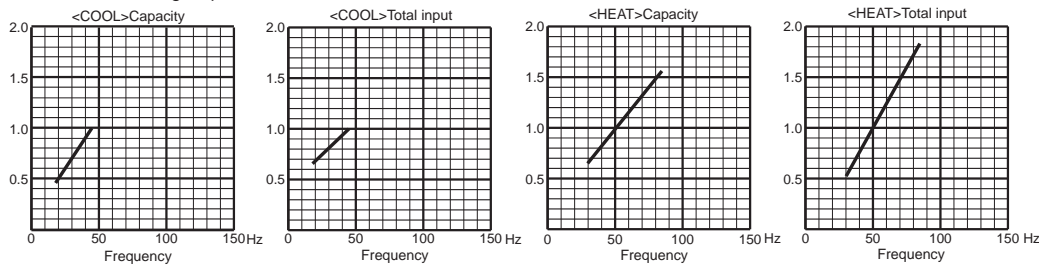

4. 15-class unit in single operation

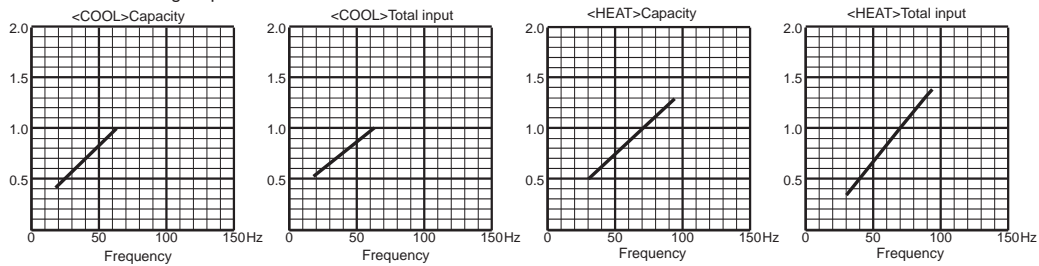

**(OUTDOOR UNIT: MXZ-3C24NA MXZ-3C24NA2 MXZ-3C24NA3 MXZ-3C24NA4
 MXZ-3C30NA MXZ-3C30NA2 MXZ-3C30NA3 MXZ-3C30NA4
 MXZ-4C36NA MXZ-4C36NA2 MXZ-4C36NA3 MXZ-4C36NA4)**

1. 06-class unit in single operation

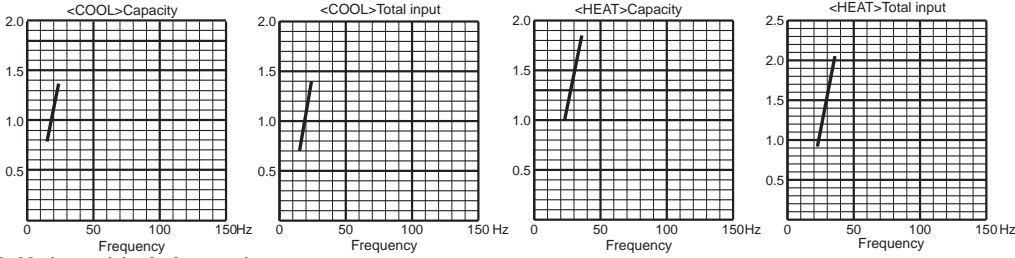

2. 09-class unit in single operation

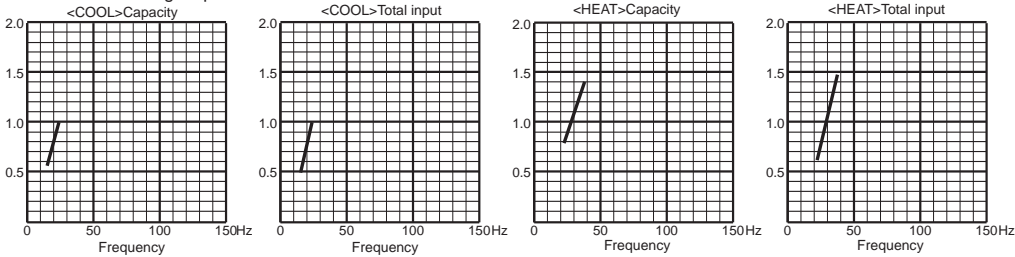

3. 12-class unit in single operation

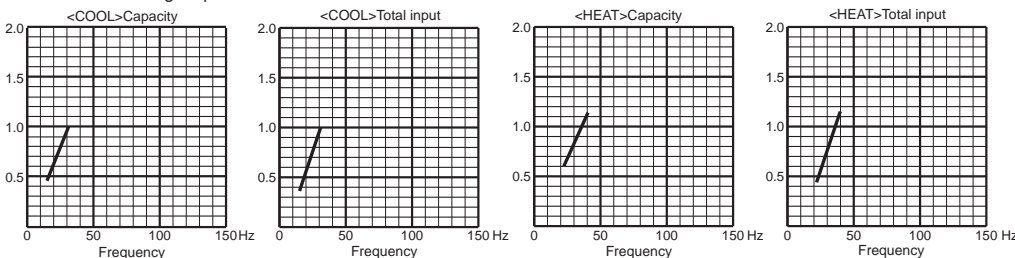

4. 15-class unit in single operation

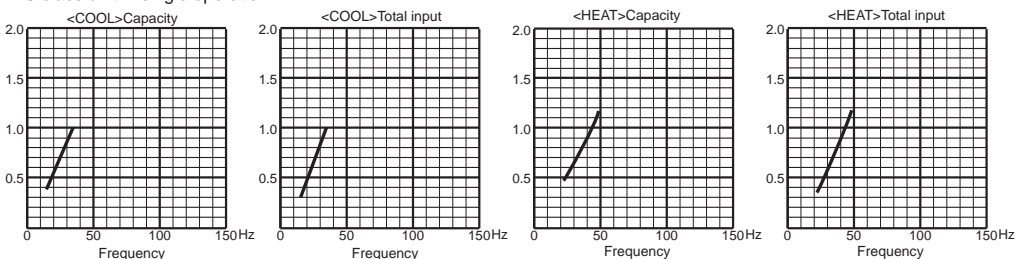

5. 18-class unit in single operation

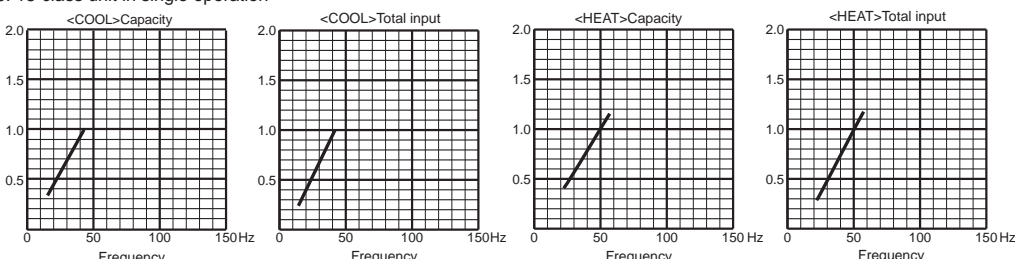

6. 24-class unit in single operation (MXZ-3C30/4C36NA, MXZ-3C30/4C36NA2 only)

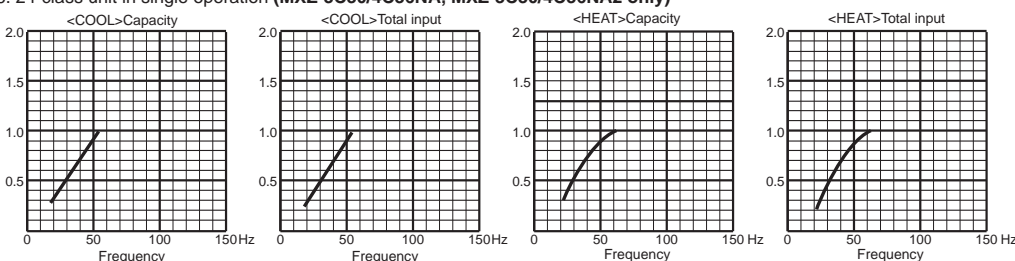

**(OUTDOOR UNIT: MXZ-5C42NA MXZ-5C42NA2 MXZ-5C42NA3 MXZ-5C42NA4
 MXZ-2C20NAHZ MXZ-2C20NAHZ2 MXZ-2C20NAHZ3 MXZ-2C20NAHZ4
 MXZ-3C24NAHZ MXZ-3C24NAHZ2 MXZ-3C24NAHZ3 MXZ-3C24NAHZ4
 MXZ-3C30NAHZ MXZ-3C30NAHZ2 MXZ-3C30NAHZ3 MXZ-3C30NAHZ4)**

1. 06-class unit in single operation

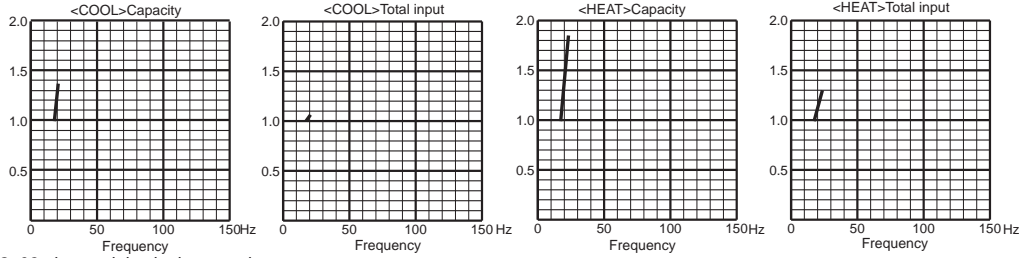

2. 09-class unit in single operation

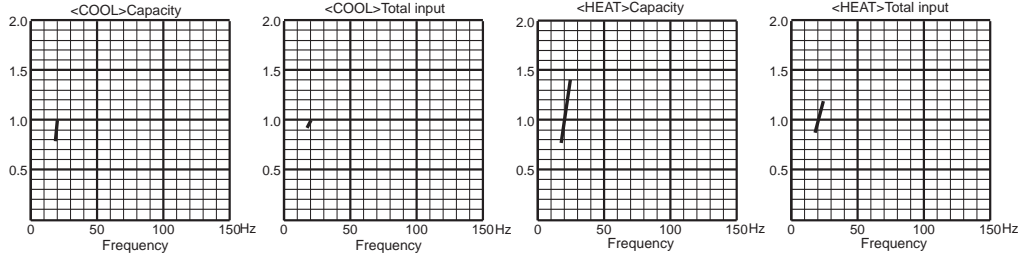

3. 12-class unit in single operation

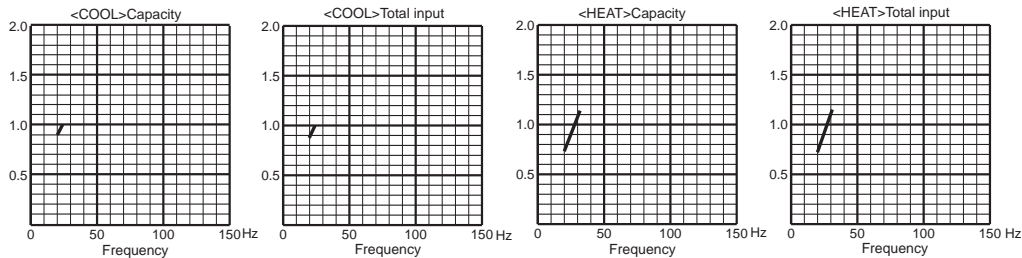

4. 15-class unit in single operation

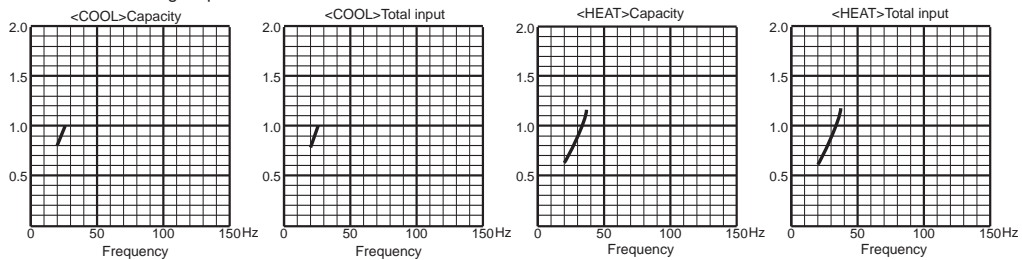

5. 18-class unit in single operation (MXZ-5C42NA, MXZ-5C42NA2, MXZ-3C24/30NAHZ, MXZ-3C24/30NAHZ2 only)

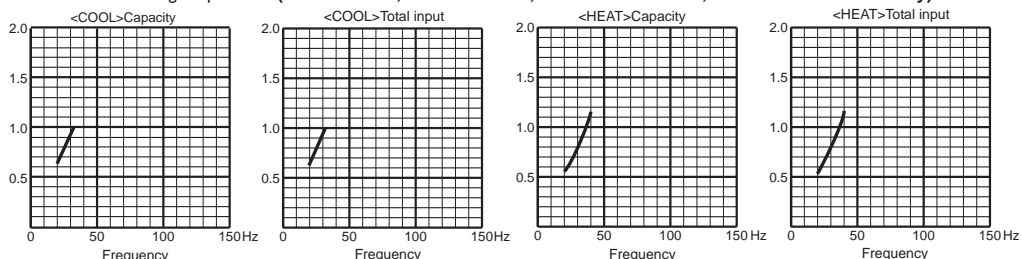

6. 24-class unit in single operation (MXZ-5C42NA, MXZ-5C42NA2, MXZ-3C30NAHZ, MXZ-3C30NAHZ2 only)

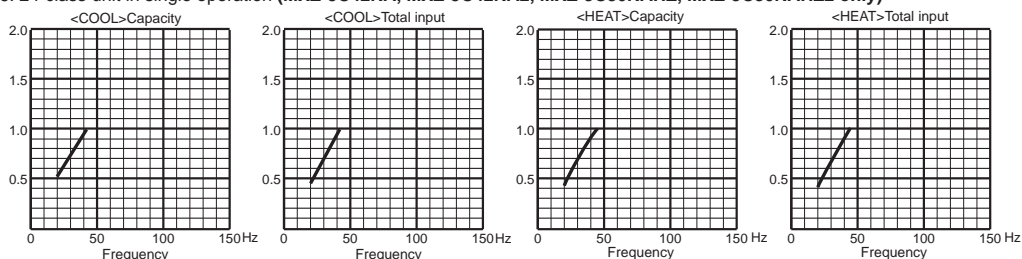

9-4. OUTDOOR LOW PRESSURE AND OUTDOOR UNIT CURRENT

1. 06-class unit in single operation (OUTDOOR UNIT: MXZ-2C20NA2 MXZ-2C20NA3 MXZ-2C20NA4)

(1) COOL operation

- ① Data is based on the condition of indoor humidity 50%
- ② Air flow speed: High
- ③ Inverter output frequency: 40 Hz

<How to work fixed-frequency operation>

1. Set emergency switch to COOL or HEAT. The switch is located on indoor unit.
2. Press emergency run ON/OFF button.
3. Compressor starts running at 40 Hz (COOL) or 48 Hz (HEAT).
4. Indoor fan runs at High speed and continues for 30 minutes.
5. To cancel this operation, press emergency run ON/OFF button or any button on remote controller.

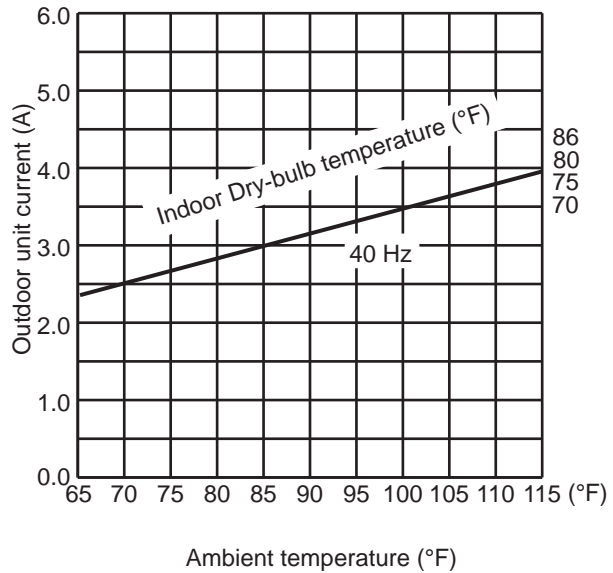
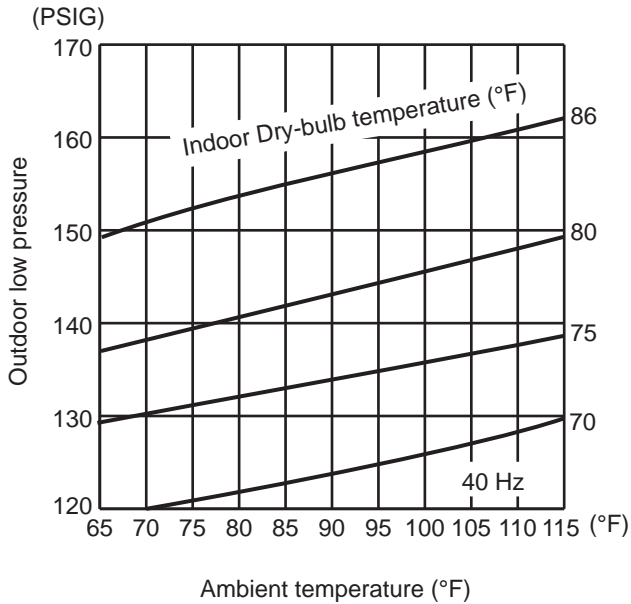

(2) HEAT operation

- ① Data is based on the condition of indoor humidity 75%
- ② Set air flow to High speed.
- ③ Inverter output frequency is 48 Hz.

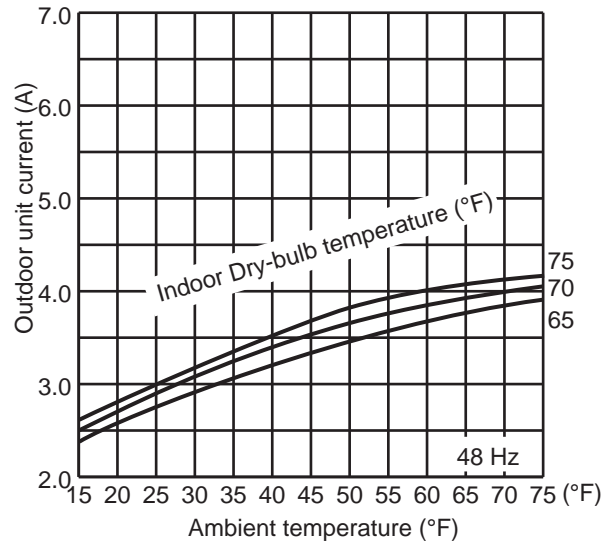

2. 09-class unit in single operation (OUTDOOR UNIT: MXZ-2C20NA2 MXZ-2C20NA3 MXZ-2C20NA4)

(1) COOL operation

- ① Data is based on the condition of indoor humidity 50%
- ② Air flow speed: High
- ③ Inverter output frequency: 40 Hz

<How to work fixed-frequency operation>

1. Set emergency switch to COOL or HEAT. The switch is located on indoor unit.
2. Press emergency run ON/OFF button.
3. Compressor starts running at 40 Hz (COOL) or 48 Hz (HEAT).
4. Indoor fan runs at High speed and continues for 30 minutes.
5. To cancel this operation, press emergency run ON/OFF button or any button on remote controller.

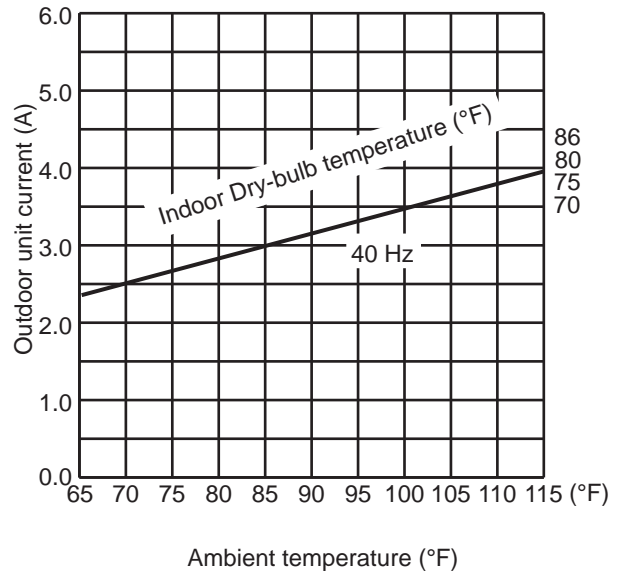
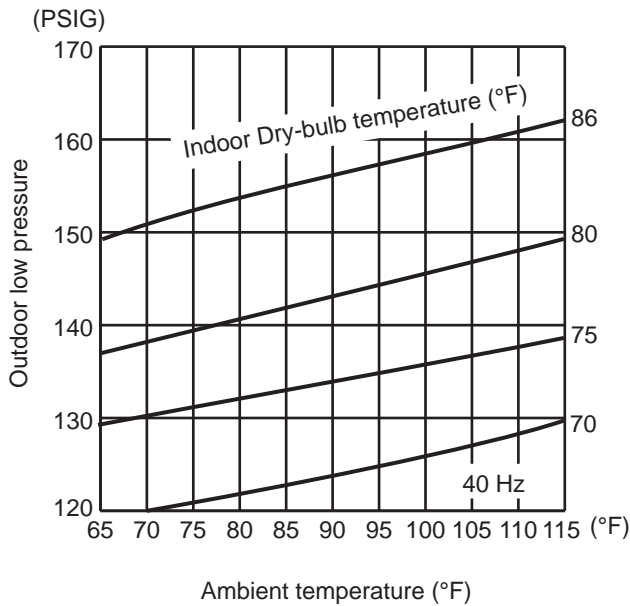

(2) HEAT operation

- ① Data is based on the condition of indoor humidity 75%
- ② Set air flow to High speed.
- ③ Inverter output frequency is 48 Hz.

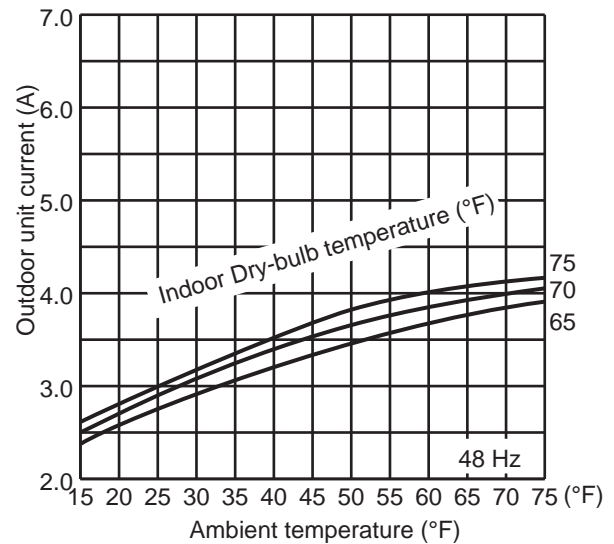

3. 12-class unit in single operation (OUTDOOR UNIT: MXZ-2C20NA2 MXZ-2C20NA3 MXZ-2C20NA4)

(1) COOL operation

- ① Data is based on the condition of indoor humidity 50%
- ② Air flow speed: High
- ③ Inverter output frequency: 40 Hz

<How to work fixed-frequency operation>

1. Set emergency switch to COOL or HEAT. The switch is located on indoor unit.
2. Press emergency run ON/OFF button.
3. Compressor starts running at 40 Hz (COOL) or 48 Hz (HEAT).
4. Indoor fan runs at High speed and continues for 30 minutes.
5. To cancel this operation, press emergency run ON/OFF button or any button on remote controller.

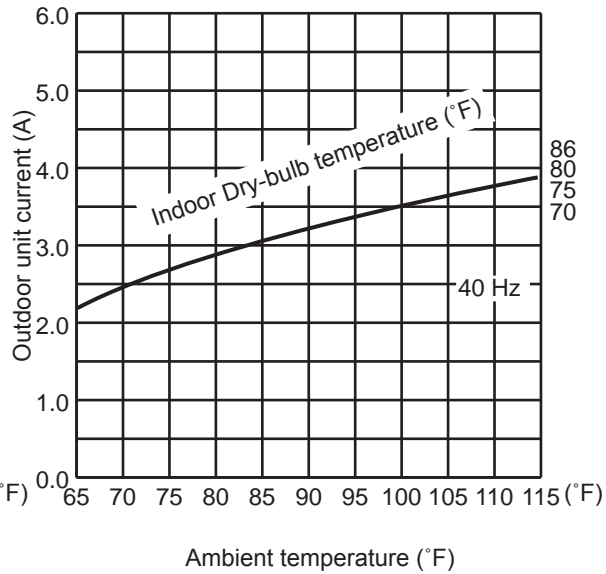
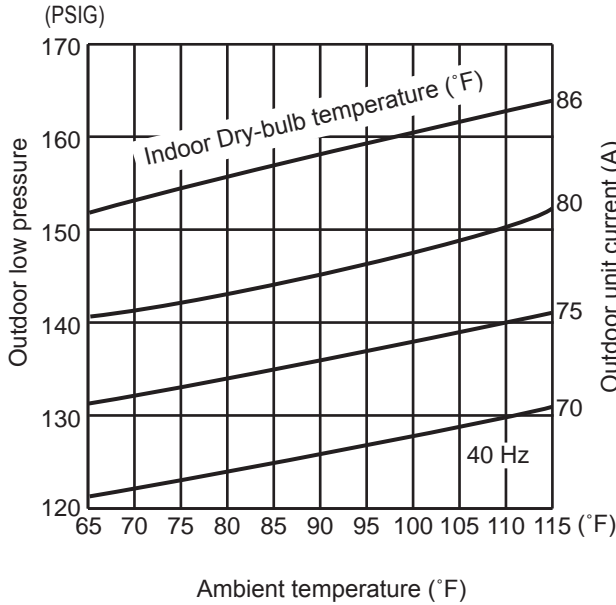

(2) HEAT operation

- ① Data is based on the condition of indoor humidity 75%
- ② Set air flow to High speed.
- ③ Inverter output frequency is 48 Hz.

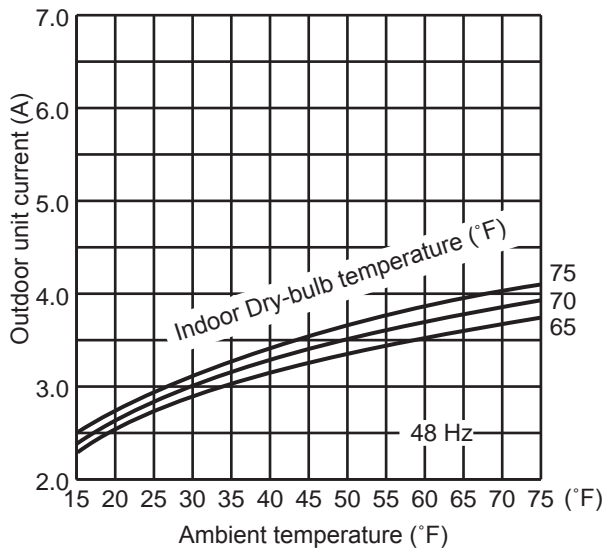

4. 15-class unit in single operation (OUTDOOR UNIT: MXZ-2C20NA2 MXZ-2C20NA3 MXZ-2C20NA4)
(1) COOL operation

- ① Data is based on the condition of indoor humidity 50%
- ② Air flow speed: High
- ③ Inverter output frequency: 40 Hz

<How to work fixed-frequency operation>

1. Set emergency switch to COOL or HEAT. The switch is located on indoor unit.
2. Press emergency run ON/OFF button.
3. Compressor starts running at 40 Hz (COOL) or 48 Hz (HEAT).
4. Indoor fan runs at High speed and continues for 30 minutes.
5. To cancel this operation, press emergency run ON/OFF button or any button on remote controller.

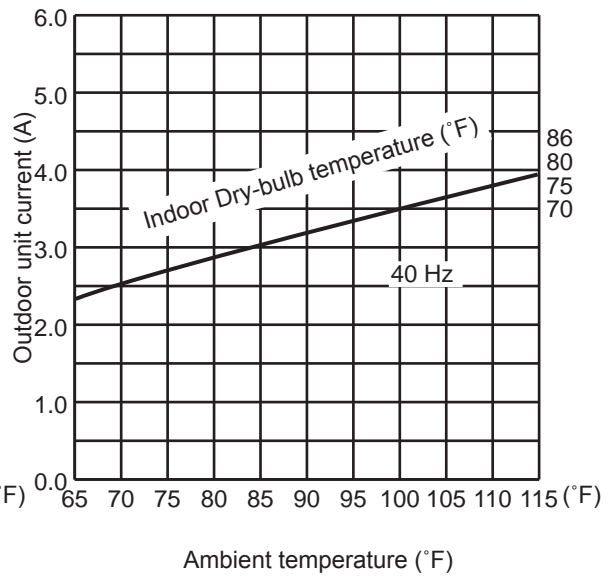
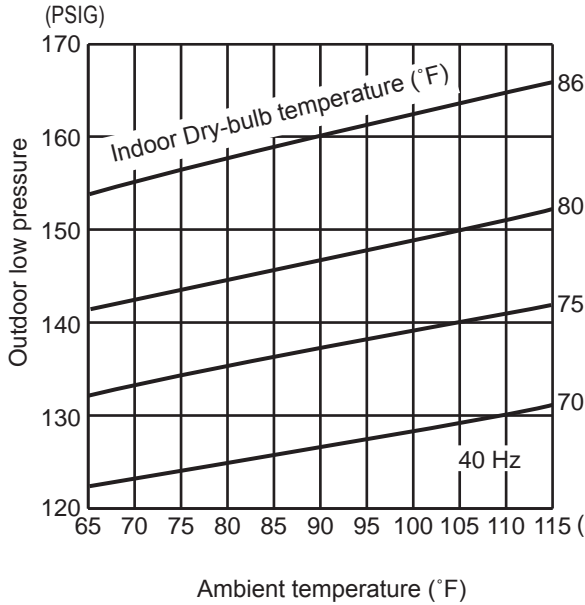

(2) HEAT operation

- ① Data is based on the condition of indoor humidity 75%
- ② Set air flow to High speed.
- ③ Inverter output frequency is 48 Hz.

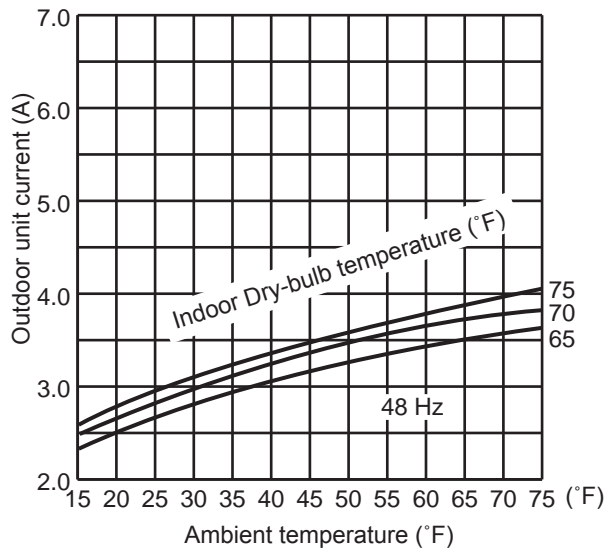

**5. 06-class unit in single operation (OUTDOOR UNIT: MXZ-3C24NA MXZ-3C24NA2 MXZ-3C24NA3 MXZ-3C24NA4
MXZ-3C30NA MXZ-3C30NA2 MXZ-3C30NA3 MXZ-3C30NA4
MXZ-4C36NA MXZ-4C36NA2 MXZ-4C36NA3 MXZ-4C36NA4)**

(1) COOL operation

- ① Data is based on the condition of indoor humidity 50%
- ② Air flow speed: High
- ③ Inverter output frequency: 24 Hz

<How to work fixed-frequency operation>

1. Set emergency switch to COOL or HEAT. The switch is located on indoor unit.
2. Press emergency run ON/OFF button.
3. Compressor starts running at 24 Hz (COOL) or 32 Hz (HEAT).
4. Indoor fan runs at High speed and continues for 30 minutes.
5. To cancel this operation, press emergency run ON/OFF button or any button on remote controller.

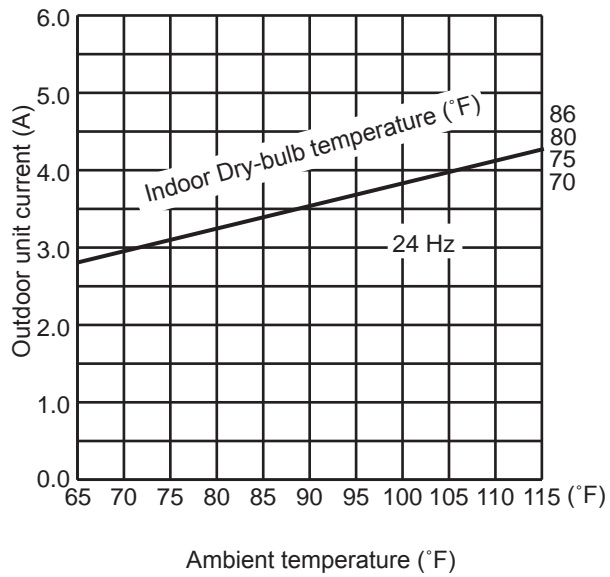
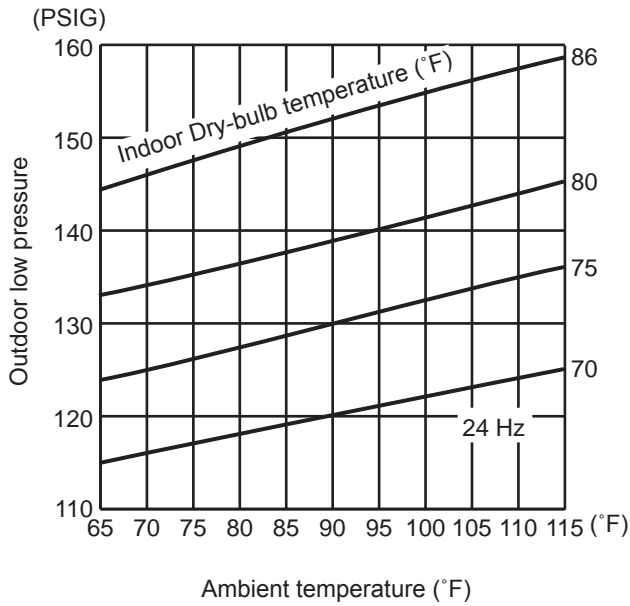

(2) HEAT operation

- ① Data is based on the condition of outdoor humidity 75%.
- ② Set air flow to High speed.
- ③ Inverter output frequency is 32 Hz.

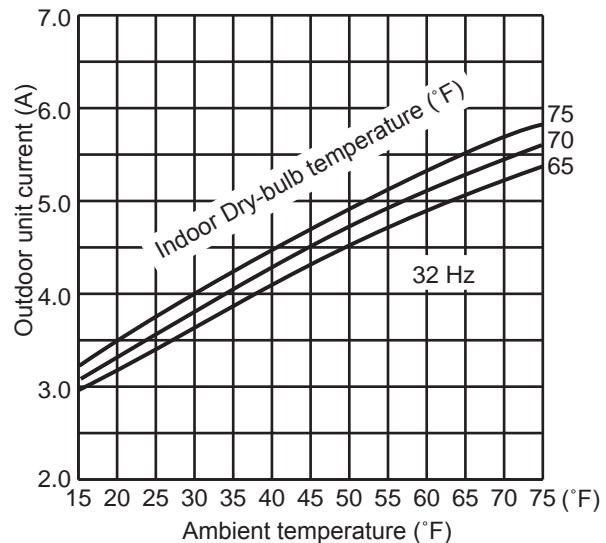

**6. 09-class unit in single operation (OUTDOOR UNIT: MXZ-3C24NA MXZ-3C24NA2 MXZ-3C24NA3 MXZ-3C24NA4
MXZ-3C30NA MXZ-3C30NA2 MXZ-3C30NA3 MXZ-3C30NA4
MXZ-4C36NA MXZ-4C36NA2 MXZ-4C36NA3 MXZ-4C36NA4)**

(1) COOL operation

- ① Data is based on the condition of indoor humidity 50%
- ② Air flow speed: High
- ③ Inverter output frequency: 24 Hz

<How to work fixed-frequency operation>

1. Set emergency switch to COOL or HEAT. The switch is located on indoor unit.
2. Press emergency run ON/OFF button.
3. Compressor starts running at 24 Hz (COOL) or 32 Hz (HEAT).
4. Indoor fan runs at High speed and continues for 30 minutes.
5. To cancel this operation, press emergency run ON/OFF button or any button on remote controller.

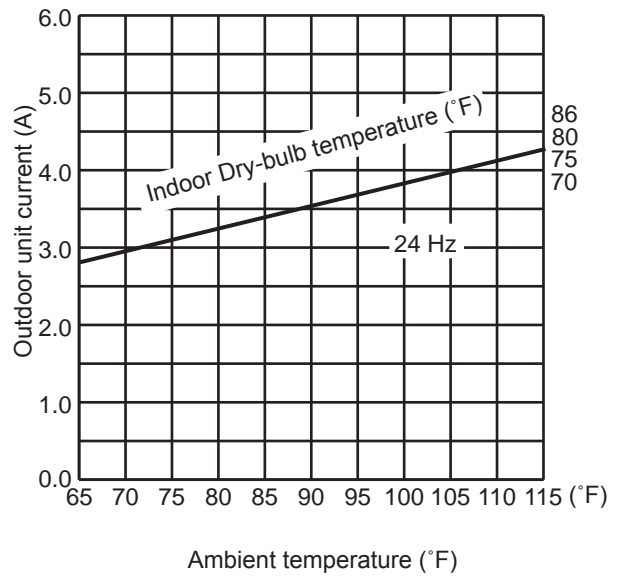
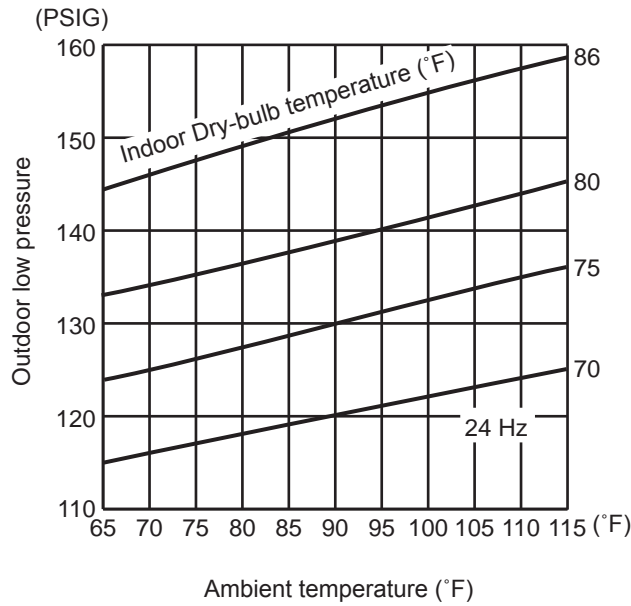

(2) HEAT operation

- ① Data is based on the condition of outdoor humidity 75%.
- ② Set air flow to High speed.
- ③ Inverter output frequency is 32 Hz.

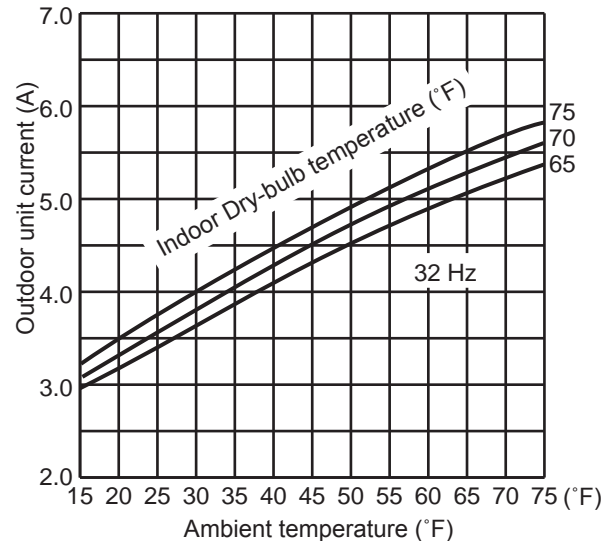

**7. 12-class unit in single operation (OUTDOOR UNIT: MXZ-3C24NA MXZ-3C24NA2 MXZ-3C24NA3 MXZ-3C24NA4
MXZ-3C30NA MXZ-3C30NA2 MXZ-3C30NA3 MXZ-3C30NA4
MXZ-4C36NA MXZ-4C36NA2 MXZ-4C36NA3 MXZ-4C36NA4)**

(1) COOL operation

- ① Data is based on the condition of indoor humidity 50%
- ② Air flow speed: High
- ③ Inverter output frequency: 24 Hz

<How to work fixed-frequency operation>

1. Set emergency switch to COOL or HEAT. The switch is located on indoor unit.
2. Press emergency run ON/OFF button.
3. Compressor starts running at 24 Hz (COOL) or 32 Hz (HEAT).
4. Indoor fan runs at High speed and continues for 30 minutes.
5. To cancel this operation, press emergency run ON/OFF button or any button on remote controller.

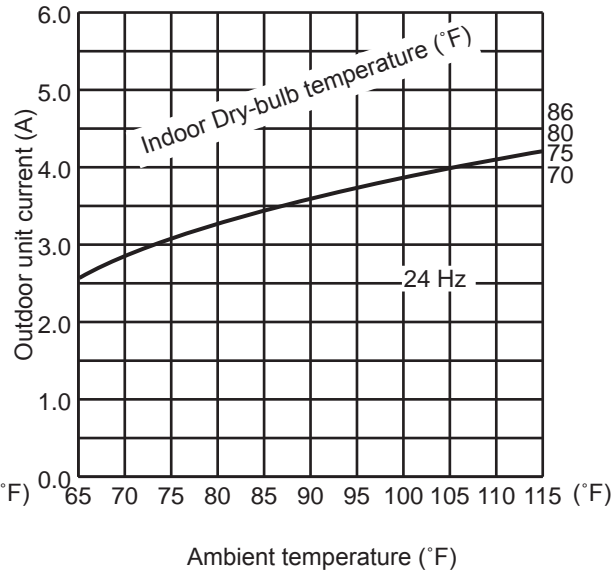
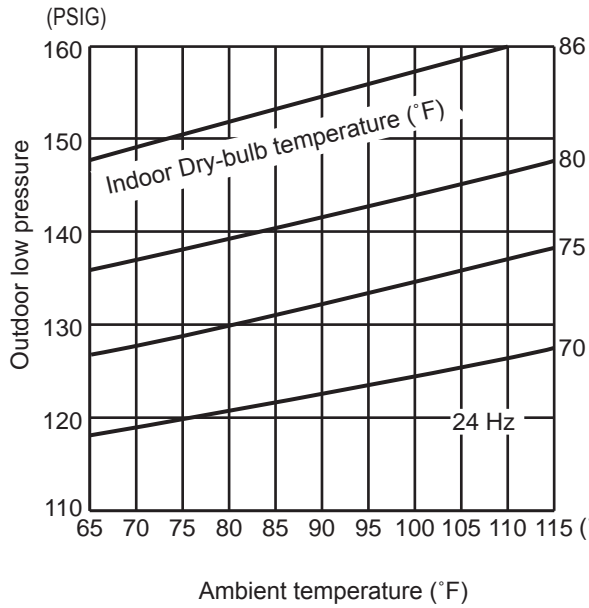

(2) HEAT operation

- ① Data is based on the condition of outdoor humidity 75%.
- ② Set air flow to High speed.
- ③ Inverter output frequency is 32 Hz.

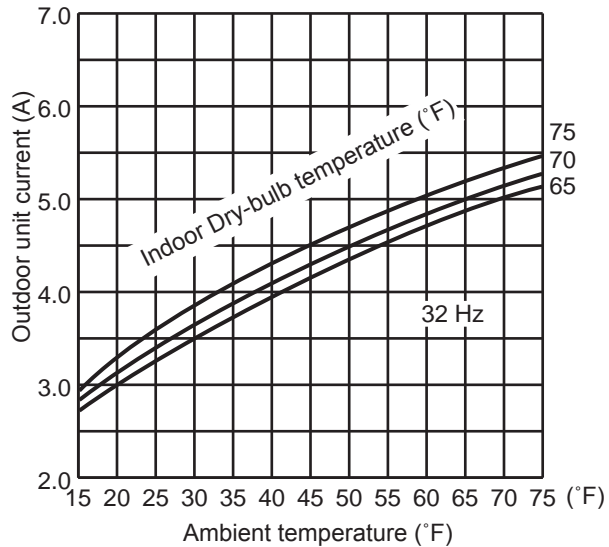

**8. 15-class unit in single operation (OUTDOOR UNIT: MXZ-3C24NA MXZ-3C24NA2 MXZ-3C24NA3 MXZ-3C24NA4
MXZ-3C30NA MXZ-3C30NA2 MXZ-3C30NA3 MXZ-3C30NA4
MXZ-4C36NA MXZ-4C36NA2 MXZ-4C36NA3 MXZ-4C36NA4)**

(1) COOL operation

- ① Data is based on the condition of indoor humidity 50%
- ② Air flow speed: High
- ③ Inverter output frequency: 24 Hz

<How to work fixed-frequency operation>

1. Set emergency switch to COOL or HEAT. The switch is located on indoor unit.
2. Press emergency run ON/OFF button.
3. Compressor starts running at 24 Hz (COOL) or 32 Hz (HEAT).
4. Indoor fan runs at High speed and continues for 30 minutes.
5. To cancel this operation, press emergency run ON/OFF button or any button on remote controller.

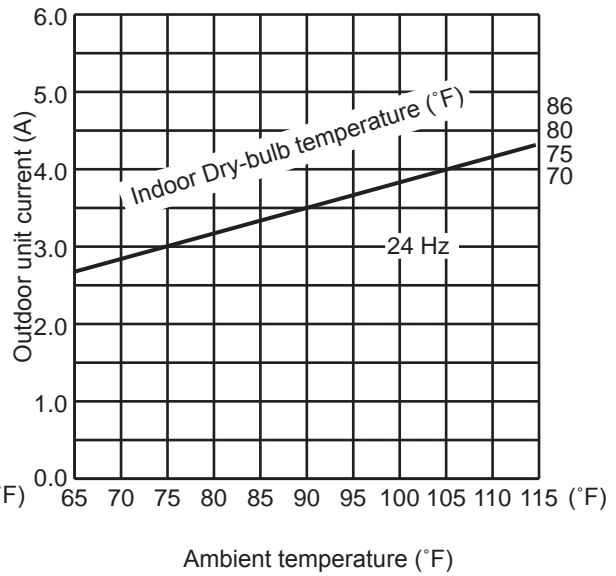
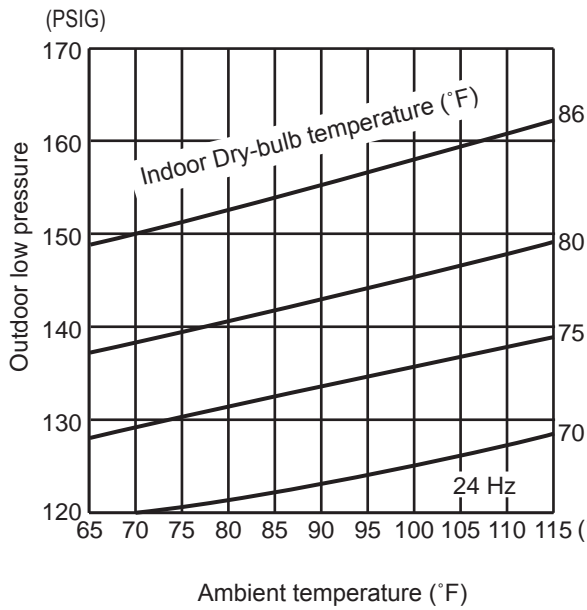

(2) HEAT operation

- ① Data is based on the condition of outdoor humidity 75%
- ② Set air flow to High speed.
- ③ Inverter output frequency is 32 Hz.

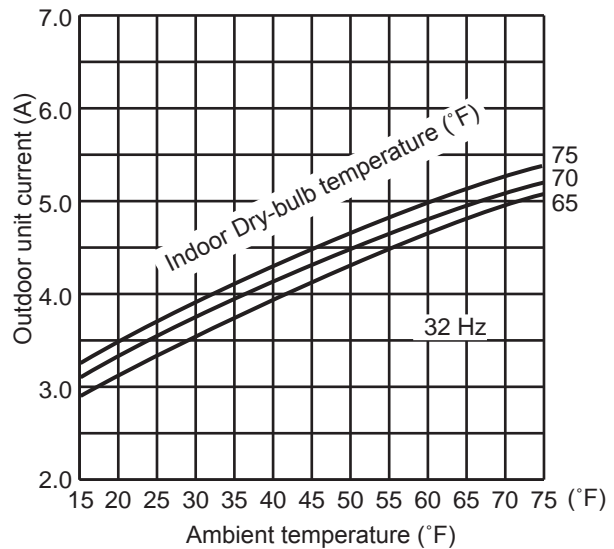

**9. 18-class unit in single operation (OUTDOOR UNIT: MXZ-3C24NA MXZ-3C24NA2 MXZ-3C24NA3 MXZ-3C24NA4
MXZ-3C30NA MXZ-3C30NA2 MXZ-3C30NA3 MXZ-3C30NA4
MXZ-4C36NA MXZ-4C36NA2 MXZ-4C36NA3 MXZ-4C36NA4)**

(1) COOL operation

- ① Data is based on the condition of indoor humidity 50%
- ② Air flow speed: High
- ③ Inverter output frequency: 24 Hz

<How to work fixed-frequency operation>

1. Set emergency switch to COOL or HEAT. The switch is located on indoor unit.
2. Press emergency run ON/OFF button.
3. Compressor starts running at 24 Hz (COOL) or 32 Hz (HEAT).
4. Indoor fan runs at High speed and continues for 30 minutes.
5. To cancel this operation, press emergency run ON/OFF button or any button on remote controller.

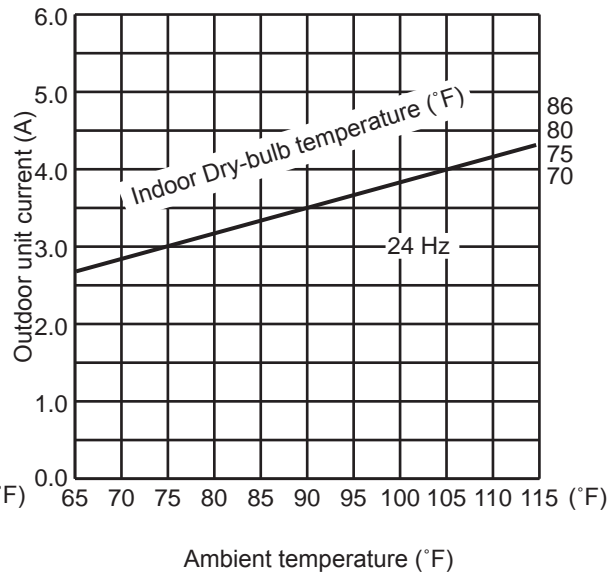
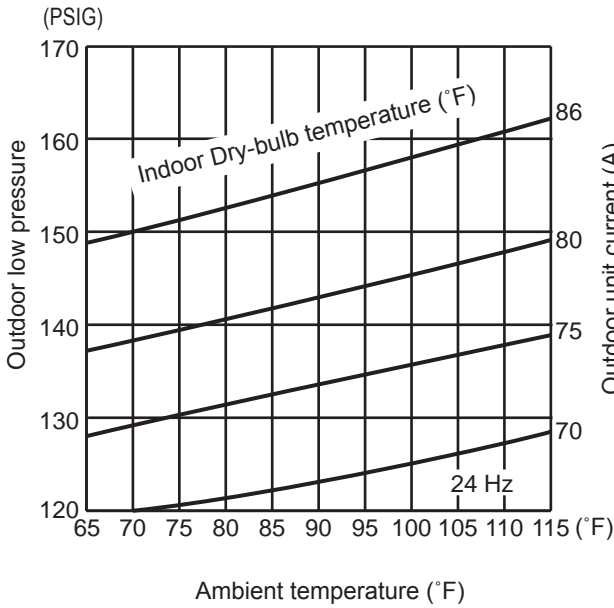

(2) HEAT operation

- ① Data is based on the condition of outdoor humidity 75%.
- ② Set air flow to High speed.
- ③ Inverter output frequency is 32 Hz.

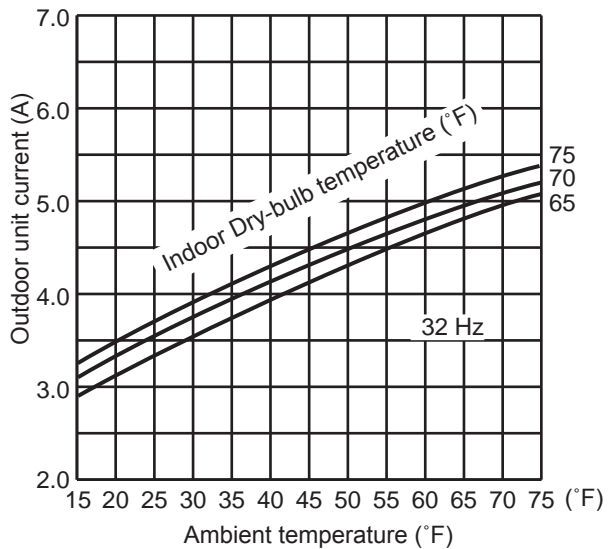

**10. 24-class unit in single operation (OUTDOOR UNIT: MXZ-3C30NA MXZ-3C30NA2 MXZ-3C30NA3 MXZ-3C30NA4
MXZ-4C36NA MXZ-4C36NA2 MXZ-4C36NA3 MXZ-4C36NA4)**

(1) COOL operation

- ① Data is based on the condition of indoor humidity 50%
- ② Air flow speed: High
- ③ Inverter output frequency: 24 Hz

<How to work fixed-frequency operation>

1. Set emergency switch to COOL or HEAT. The switch is located on indoor unit.
2. Press emergency run ON/OFF button.
3. Compressor starts running at 24 Hz (COOL) or 32 Hz (HEAT).
4. Indoor fan runs at High speed and continues for 30 minutes.
5. To cancel this operation, press emergency run ON/OFF button or any button on remote controller.

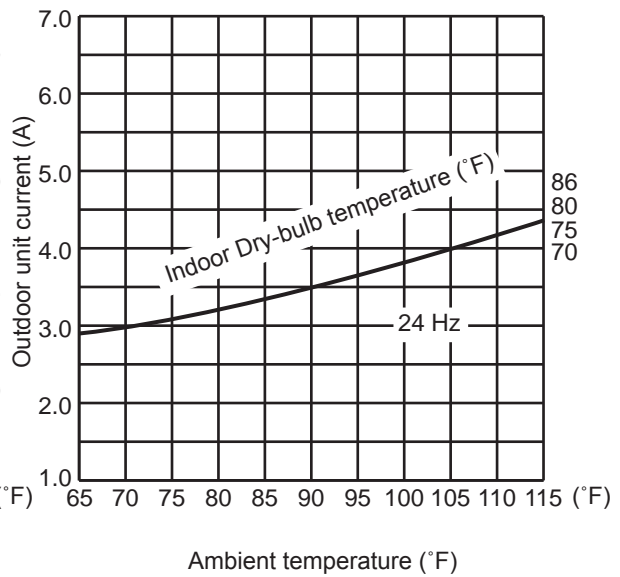
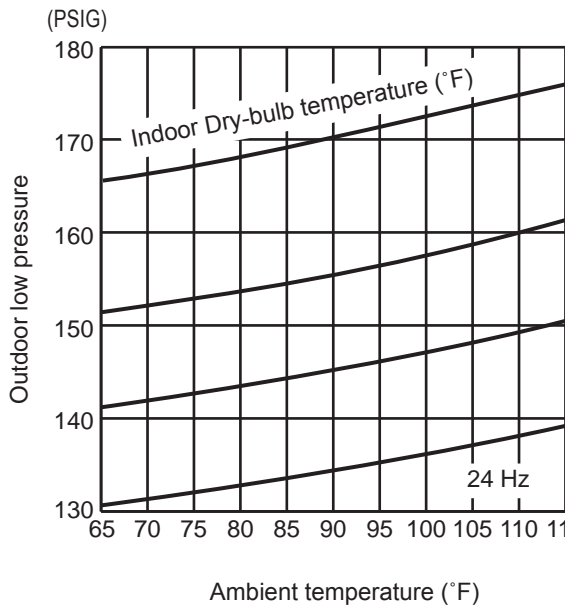

(2) HEAT operation

- ① Data is based on the condition of outdoor humidity 75%
- ② Set air flow to High speed.
- ③ Inverter output frequency is 32 Hz.

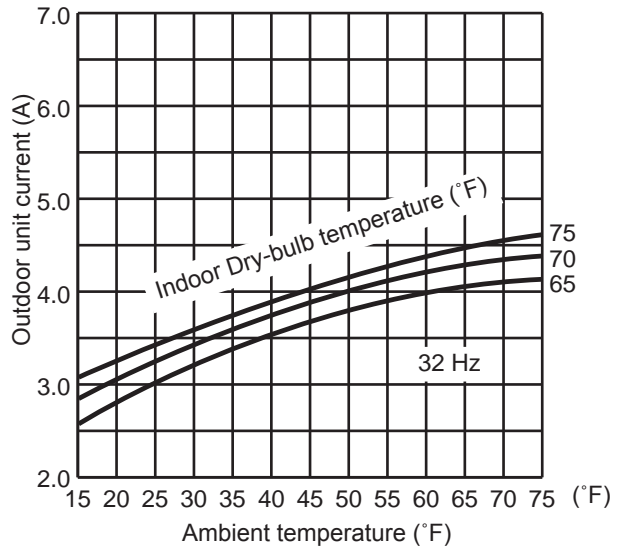

11. 06-class unit in single operation

(OUTDOOR UNIT: MXZ-5C42NA MXZ-2C20NAHZ MXZ-3C24NAHZ MXZ-3C30NAHZ
 MXZ-5C42NA2 MXZ-2C20NAHZ2 MXZ-3C24NAHZ2 MXZ-3C30NAHZ2
 MXZ-5C42NA3 MXZ-2C20NAHZ3 MXZ-3C24NAHZ3 MXZ-3C30NAHZ3
 MXZ-5C42NA4 MXZ-2C20NAHZ4 MXZ-3C24NAHZ4 MXZ-3C30NAHZ4)

(1) COOL operation

- ① Data is based on the condition of indoor humidity 50%
- ② Air flow speed: High
- ③ Inverter output frequency: 18 Hz

<How to work fixed-frequency operation>

1. Set emergency switch to COOL or HEAT. The switch is located on indoor unit.
2. Press emergency run ON/OFF button.
3. Compressor starts running at 18 Hz (COOL) or 20 Hz (HEAT).
4. Indoor fan runs at High speed and continues for 30 minutes.
5. To cancel this operation, press emergency run ON/OFF button or any button on remote controller.

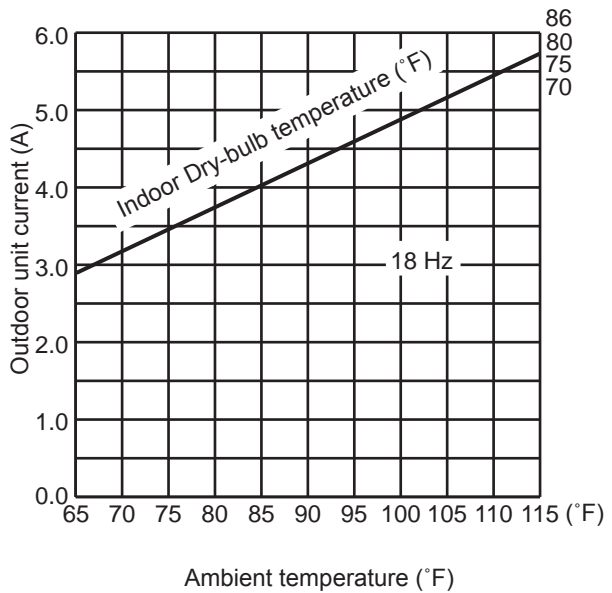
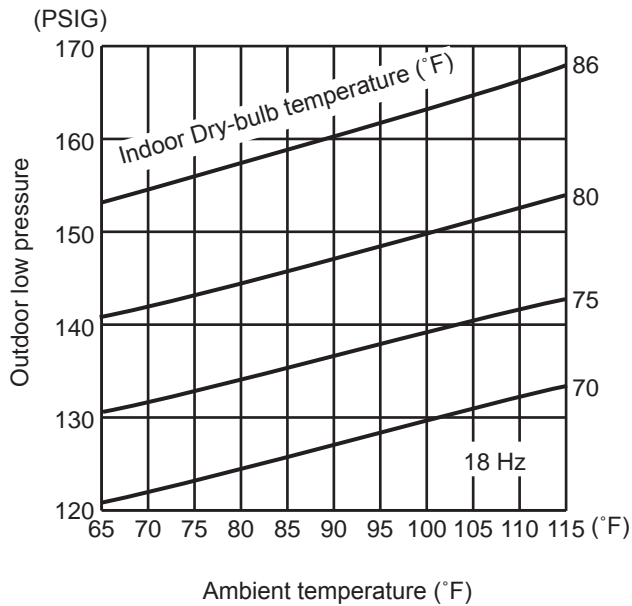

(2) HEAT operation

- ① Data is based on the condition of outdoor humidity 75%.
- ② Set air flow to High speed.
- ③ Inverter output frequency is 20 Hz.

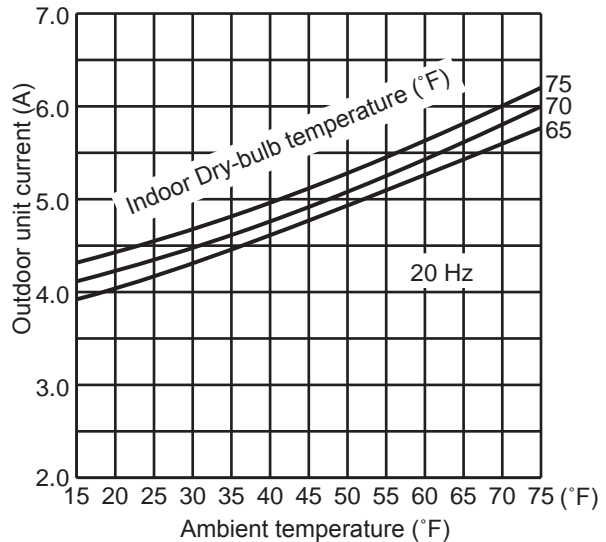

12. 09-class unit in single operation

(OUTDOOR UNIT: MXZ-5C42NA MXZ-2C20NAHZ MXZ-3C24NAHZ MXZ-3C30NAHZ
 MXZ-5C42NA2 MXZ-2C20NAHZ2 MXZ-3C24NAHZ2 MXZ-3C30NAHZ2
 MXZ-5C42NA3 MXZ-2C20NAHZ3 MXZ-3C24NAHZ3 MXZ-3C30NAHZ3
 MXZ-5C42NA4 MXZ-2C20NAHZ4 MXZ-3C24NAHZ4 MXZ-3C30NAHZ4)

(1) COOL operation

- ① Data is based on the condition of indoor humidity 50%
- ② Air flow speed: High
- ③ Inverter output frequency: 18 Hz

<How to work fixed-frequency operation>

1. Set emergency switch to COOL or HEAT. The switch is located on indoor unit.
2. Press emergency run ON/OFF button.
3. Compressor starts running at 18 Hz (COOL) or 20 Hz (HEAT).
4. Indoor fan runs at High speed and continues for 30 minutes.
5. To cancel this operation, press emergency run ON/OFF button or any button on remote controller.

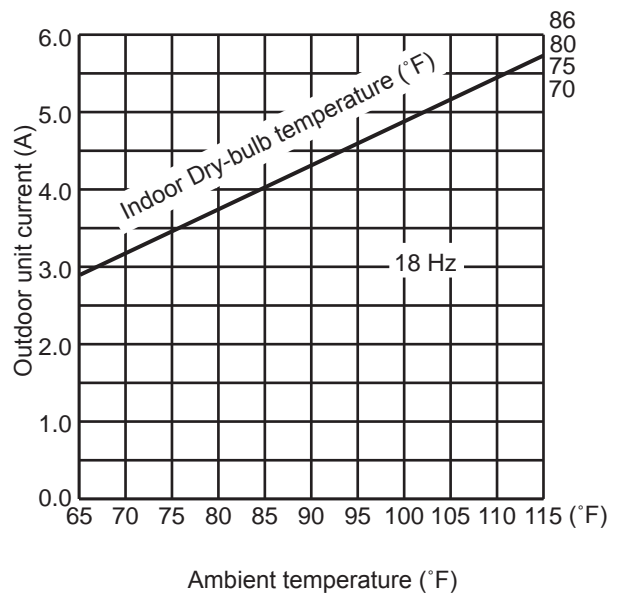
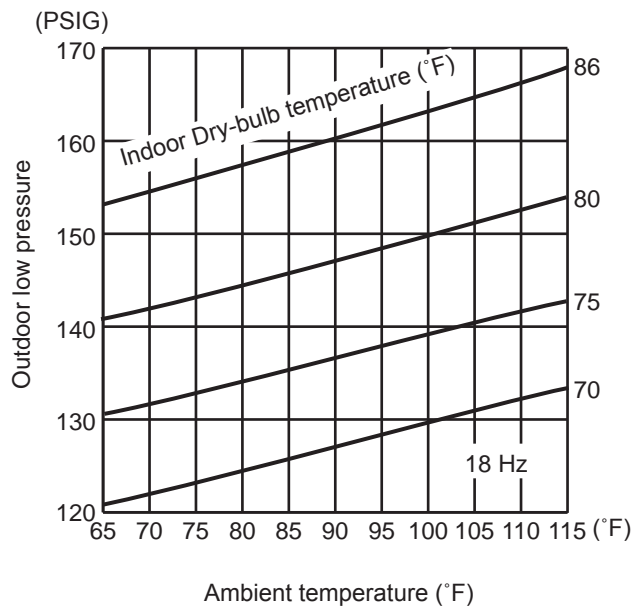

(2) HEAT operation

- ① Data is based on the condition of outdoor humidity 75%.
- ② Set air flow to High speed.
- ③ Inverter output frequency is 20 Hz.

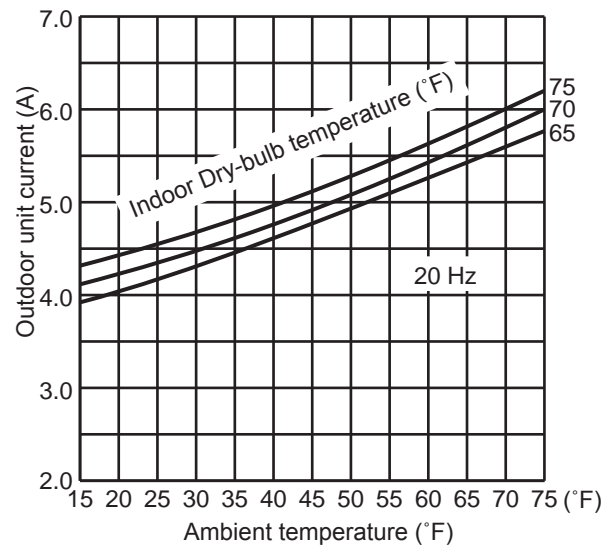

13. 12-class unit in single operation

(OUTDOOR UNIT: MXZ-5C42NA MXZ-5C42NA2 MXZ-5C42NA3 MXZ-5C42NA4
 MXZ-2C20NAHZ MXZ-2C20NAHZ2 MXZ-2C20NAHZ3 MXZ-2C20NAHZ4
 MXZ-3C24NAHZ MXZ-3C24NAHZ2 MXZ-3C24NAHZ3 MXZ-3C24NAHZ4
 MXZ-3C30NAHZ MXZ-3C30NAHZ2 MXZ-3C30NAHZ3 MXZ-3C30NAHZ4)

(1) COOL operation

- ① Data is based on the condition of indoor humidity 50%
- ② Air flow speed: High
- ③ Inverter output frequency: 18 Hz

<How to work fixed-frequency operation>

1. Set emergency switch to COOL or HEAT. The switch is located on indoor unit.
2. Press emergency run ON/OFF button.
3. Compressor starts running at 18 Hz (COOL) or 20 Hz (HEAT).
4. Indoor fan runs at High speed and continues for 30 minutes.
5. To cancel this operation, press emergency run ON/OFF button or any button on remote controller.

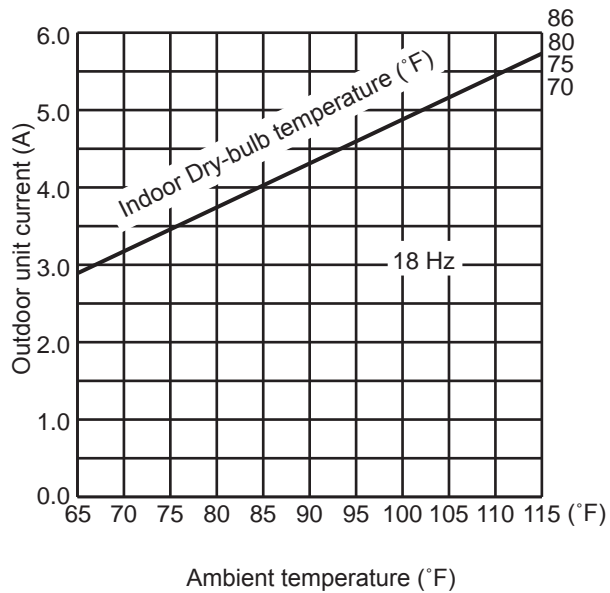
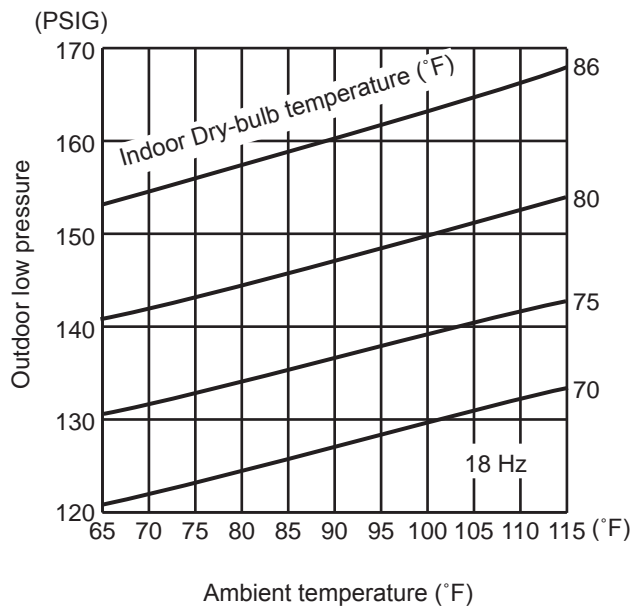

(2) HEAT operation

- ① Data is based on the condition of outdoor humidity 75%.
- ② Set air flow to High speed.
- ③ Inverter output frequency is 20 Hz.

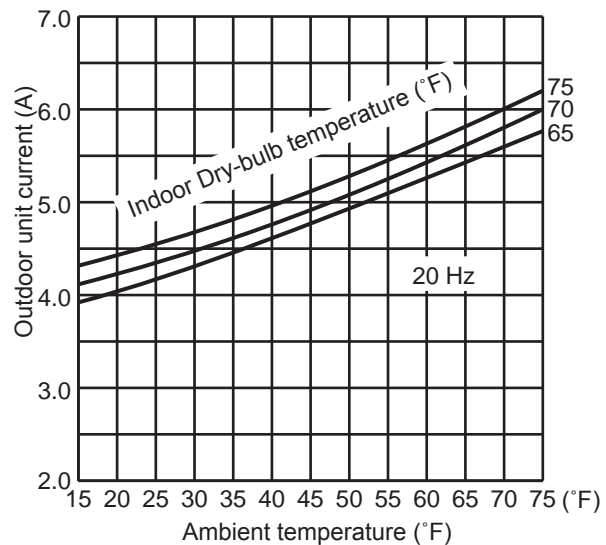

14. 15-class unit in single operation

(OUTDOOR UNIT: MXZ-5C42NA MXZ-5C42NA2 MXZ-5C42NA3 MXZ-5C42NA4
 MXZ-2C20NAHZ MXZ-2C20NAHZ2 MXZ-2C20NAHZ3 MXZ-2C20NAHZ4
 MXZ-3C24NAHZ MXZ-3C24NAHZ2 MXZ-3C24NAHZ3 MXZ-3C24NAHZ4
 MXZ-3C30NAHZ MXZ-3C30NAHZ2 MXZ-3C30NAHZ3 MXZ-3C30NAHZ4)

(1) COOL operation

- ① Data is based on the condition of indoor humidity 50%
- ② Air flow speed: High
- ③ Inverter output frequency: 18 Hz

<How to work fixed-frequency operation>

1. Set emergency switch to COOL or HEAT. The switch is located on indoor unit.
2. Press emergency run ON/OFF button.
3. Compressor starts running at 18 Hz (COOL) or 20 Hz (HEAT).
4. Indoor fan runs at High speed and continues for 30 minutes.
5. To cancel this operation, press emergency run ON/OFF button or any button on remote controller.

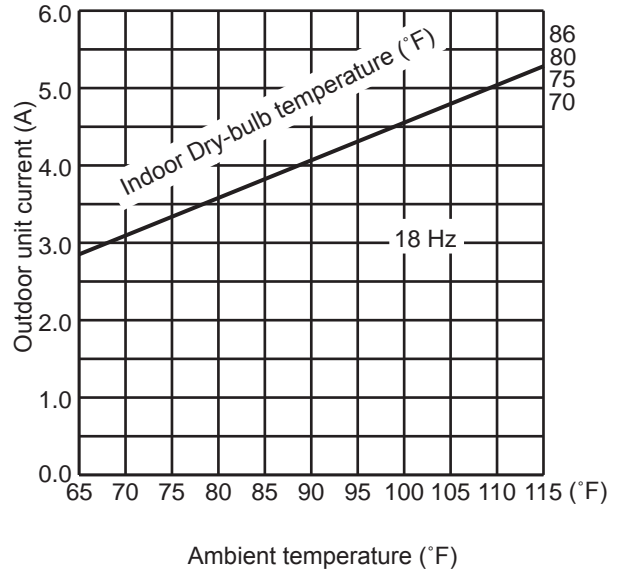
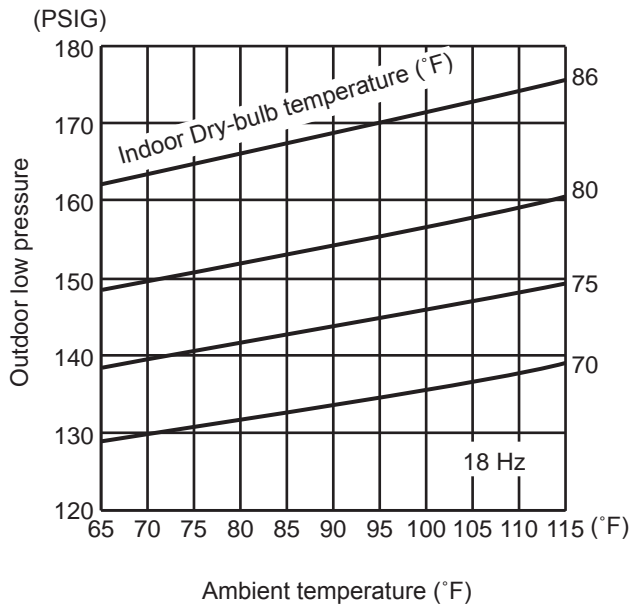

(2) HEAT operation

- ① Data is based on the condition of outdoor humidity 75%.
- ② Set air flow to High speed.
- ③ Inverter output frequency is 20 Hz.

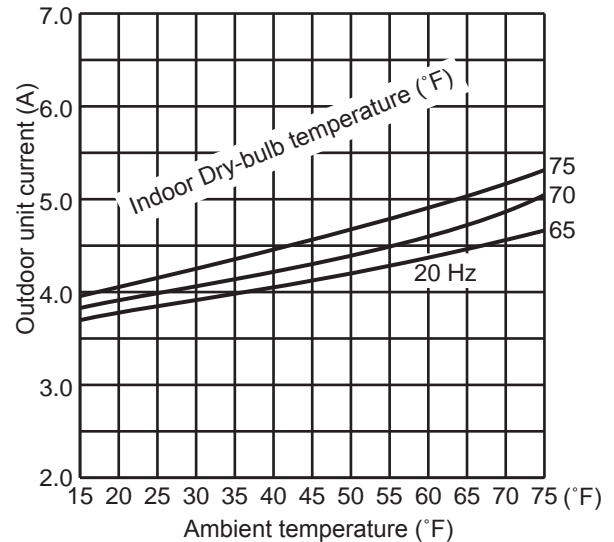

15. 18-class unit in single operation

(OUTDOOR UNIT: MXZ-5C42NA MXZ-5C42NA2 MXZ-5C42NA3 MXZ-5C42NA4
 MXZ-3C24NAHZ MXZ-3C24NAHZ2 MXZ-3C24NAHZ3 MXZ-3C24NAHZ4
 MXZ-3C30NAHZ MXZ-3C30NAHZ2 MXZ-3C30NAHZ3 MXZ-3C30NAHZ4)

(1) COOL operation

- ① Data is based on the condition of indoor humidity 50%
- ② Air flow speed: High
- ③ Inverter output frequency: 18 Hz

<How to work fixed-frequency operation>

1. Set emergency switch to COOL or HEAT. The switch is located on indoor unit.
2. Press emergency run ON/OFF button.
3. Compressor starts running at 18 Hz (COOL) or 20 Hz (HEAT).
4. Indoor fan runs at High speed and continues for 30 minutes.
5. To cancel this operation, press emergency run ON/OFF button or any button on remote controller.

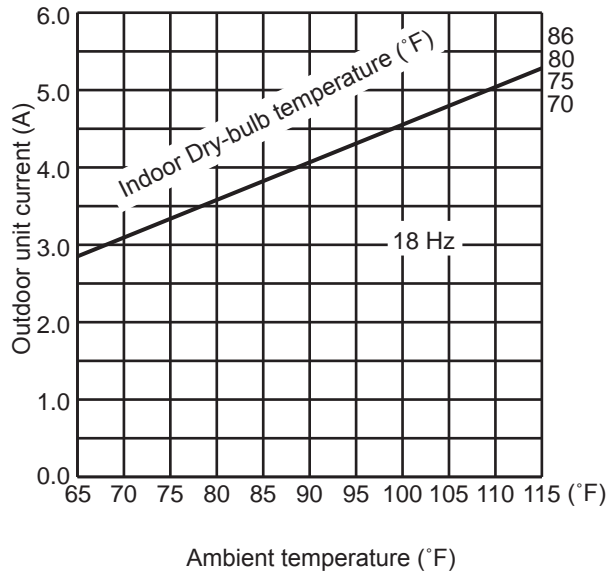
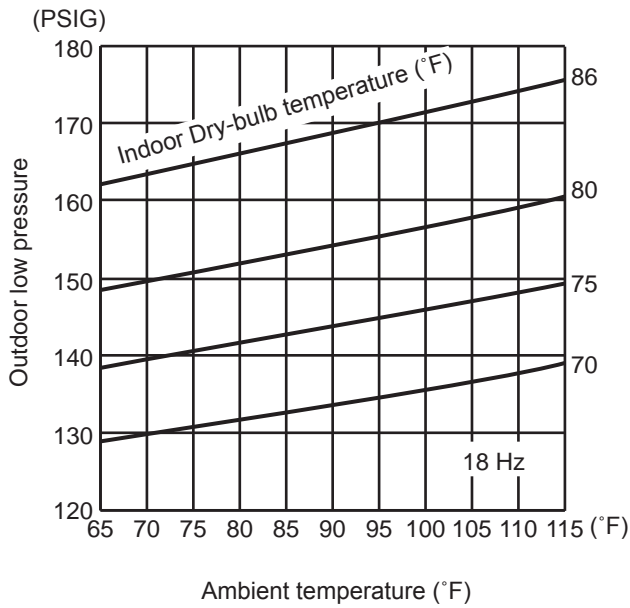

(2) HEAT operation

- ① Data is based on the condition of outdoor humidity 75%.
- ② Set air flow to High speed.
- ③ Inverter output frequency is 20 Hz.

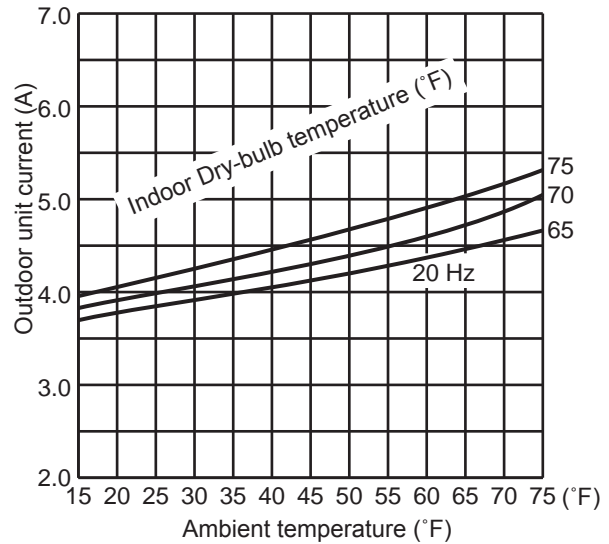

16. 24-class unit in single operation

(OUTDOOR UNIT: MXZ-5C42NA MXZ-5C42NA2 MXZ-5C42NA3 MXZ-5C42NA4
 MXZ-3C30NAHZ MXZ-3C30NAHZ2 MXZ-3C30NAHZ3 MXZ-3C30NAHZ4)

(1) COOL operation

- ① Data is based on the condition of indoor humidity 50%
- ② Air flow speed: High
- ③ Inverter output frequency: 18 Hz

<How to work fixed-frequency operation>

1. Set emergency switch to COOL or HEAT. The switch is located on indoor unit.
2. Press emergency run ON/OFF button.
3. Compressor starts running at 18 Hz (COOL) or 20 Hz (HEAT).
4. Indoor fan runs at High speed and continues for 30 minutes.
5. To cancel this operation, press emergency run ON/OFF button or any button on remote controller.

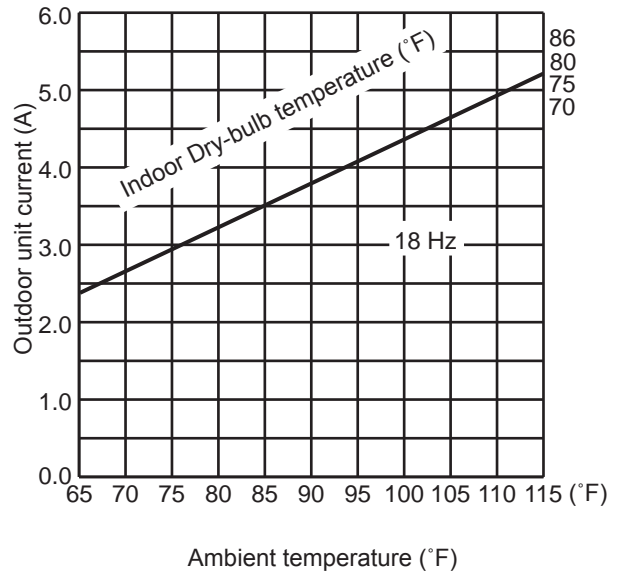
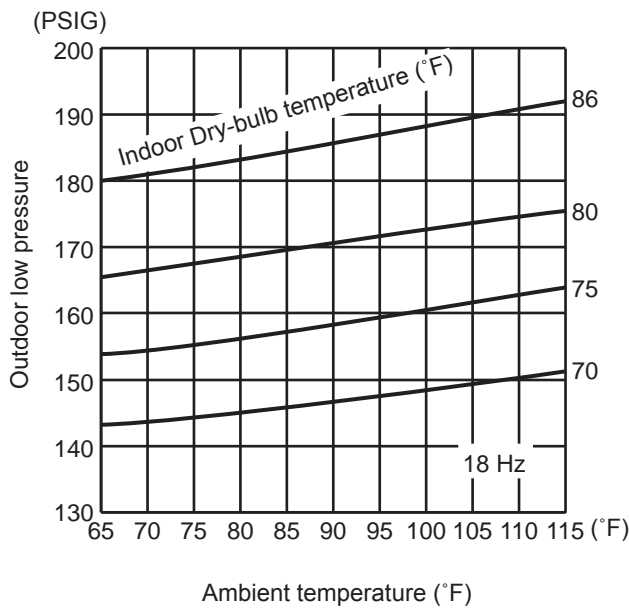

(2) HEAT operation

- ① Data is based on the condition of outdoor humidity 75%.
- ② Set air flow to High speed.
- ③ Inverter output frequency is 20 Hz.

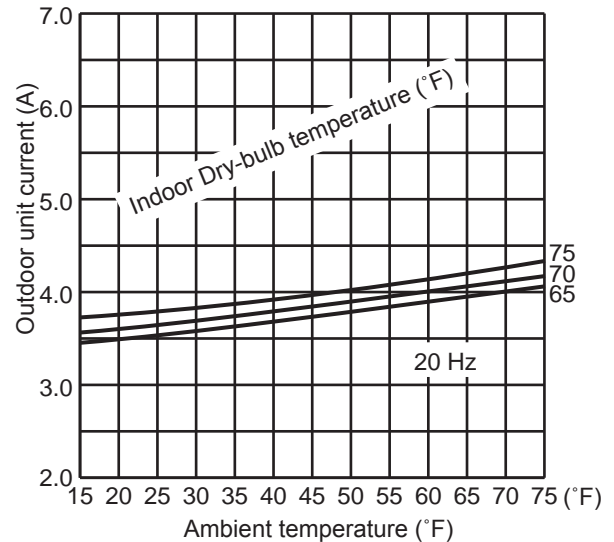

MXZ-3C24NA MXZ-3C30NA MXZ-4C36NA MXZ-5C42NA
MXZ-2C20NA2 MXZ-3C24NA2 MXZ-3C30NA2 MXZ-4C36NA2 MXZ-5C42NA2
MXZ-2C20NA3 MXZ-3C24NA3 MXZ-3C30NA3 MXZ-4C36NA3 MXZ-5C42NA3
MXZ-2C20NA4 MXZ-3C24NA4 MXZ-3C30NA4 MXZ-4C36NA4 MXZ-5C42NA4
MXZ-2C20NAHZ MXZ-3C24NAHZ MXZ-3C30NAHZ
MXZ-2C20NAHZ2 MXZ-3C24NAHZ2 MXZ-3C30NAHZ2
MXZ-2C20NAHZ3 MXZ-3C24NAHZ3 MXZ-3C30NAHZ3
MXZ-2C20NAHZ4 MXZ-3C24NAHZ4 MXZ-3C30NAHZ4

Relation between main sensor and actuator

Sensor	Purpose	Actuator					
		Compressor	LEV	Outdoor fan motor	4-way valve	2-way solenoid valve	Defrost heater
						MXZ-5C42NA MXZ-2C20NAHZ MXZ-3C24NAHZ MXZ-3C30NAHZ MXZ-5C42NA2 MXZ-2C20NAHZ2 MXZ-3C24NAHZ2 MXZ-3C30NAHZ2 MXZ-5C42NA3 MXZ-2C20NAHZ3 MXZ-3C24NAHZ3 MXZ-3C30NAHZ3 MXZ-5C42NA4 MXZ-2C20NAHZ4 MXZ-3C24NAHZ4 MXZ-3C30NAHZ4	MXZ-2C20NAHZ MXZ-3C24NAHZ MXZ-3C30NAHZ MXZ-2C20NAHZ2 MXZ-3C24NAHZ2 MXZ-3C30NAHZ3 MXZ-2C20NAHZ3 MXZ-3C24NAHZ3 MXZ-3C30NAHZ3 MXZ-2C20NAHZ4 MXZ-3C24NAHZ4 MXZ-3C30NAHZ4
Discharge temperature thermistor	Protection	○	○			○	
Indoor coil temperature thermistor	Cooling: Coil frost prevention	○				○	
	Heating: High pressure protection	○	○				
Defrost thermistor	Heating: Defrosting	○	○	○	○		
Fin temperature thermistor	Protection	○		○			
Ambient temperature thermistor	Control/Protection	○	○	○		○	
	Heating: Defrosting (Heater)						○
Outdoor heat exchanger temperature thermistor	Cooling: Control/Protection	○	○	○		○	
Capacity code	Control	○	○				

MXZ-3C24NA	MXZ-3C30NA	MXZ-4C36NA	MXZ-5C42NA	
MXZ-2C20NA2	MXZ-3C24NA2	MXZ-3C30NA2	MXZ-4C36NA2	MXZ-5C42NA2
MXZ-2C20NA3	MXZ-3C24NA3	MXZ-3C30NA3	MXZ-4C36NA3	MXZ-5C42NA3
MXZ-2C20NA4	MXZ-3C24NA4	MXZ-3C30NA4	MXZ-4C36NA4	MXZ-5C42NA4
MXZ-2C20NAHZ	MXZ-3C24NAHZ	MXZ-3C30NAHZ		
MXZ-2C20NAHZ2	MXZ-3C24NAHZ2	MXZ-3C30NAHZ2		
MXZ-2C20NAHZ3	MXZ-3C24NAHZ3	MXZ-3C30NAHZ3		
MXZ-2C20NAHZ4	MXZ-3C24NAHZ4	MXZ-3C30NAHZ4		

11-1. PRE-HEAT CONTROL

If moisture gets into the refrigerant cycle, or when refrigerant is liquefied and collected in the compressor, it may interfere the startup of the compressor.

To improve start-up condition, the compressor is energized even while it is not operating.

This is to generate heat at the winding.

The compressor uses about 50 W when pre-heat control is turned ON.

Pre-heat control is ON at initial setting.

[How to deactivate pre-heat control]

- ① Turn OFF the power supply for the air conditioner before making the setting.
- ② Set the "4" of SW2 on the outdoor control P.C. board to ON to deactivate pre-heat control function.

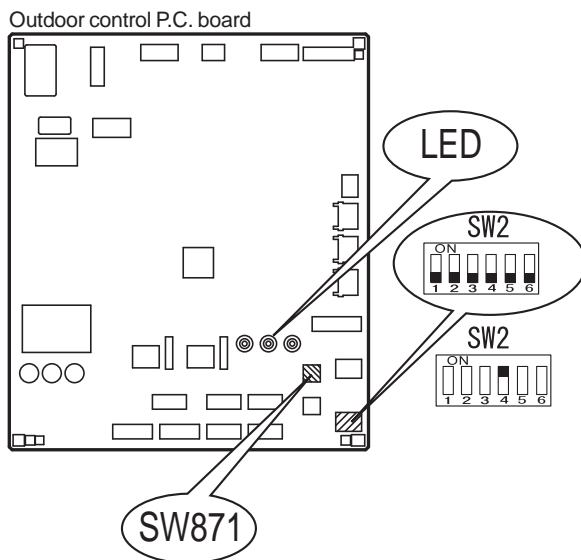

- ③ Turn ON the power supply for the air conditioner.

NOTE: Pre-heat control will be turned OFF when the breaker is turned OFF.

11-2. AUTO LINE CORRECTING

Outdoor unit has an auto line correcting function which automatically detects and corrects improper wiring or piping.

Improper wiring or piping can be automatically detected by pressing the piping/wiring correction switch (SW871). When improper wiring or piping is detected, wiring lines are corrected. This will be completed in about 10 to 20 minutes.

[How to activate this function]

1. Check that outside temperature is above 32°F.
(This function does not work when outside temperature is not above 32°F.)
2. Check that the stop valves of the liquid pipe and gas pipe are open.
3. Check that the wiring between indoor and outdoor unit is correct.
(If the wiring is not correct, this function does not work.)
4. Turn ON the power supply and wait at least 1 minute.
5. Press the piping/wiring correction switch (SW871) on the outdoor control P.C. board.
Do not touch energized parts.

LED indication during detection:

LED1 (Red)	LED2 (Yellow)	LED3 (Green)
Lit	Lit	Once

LED indication after detection:

LED1 (Red)	LED2 (Yellow)	LED3 (Green)	Indication
Lit	Not lit	Lit	Completed (Problem corrected/ normal)
Once	Once	Once	Not completed (Detection failed)
Other indications			Refer to "SAFETY PRECAUTIONS WHEN LED BLINKS" located behind the service panel.

* Make sure that the valves are open and the pipes are not collapsed or clogged.

6. Press the switch to cancel.

LED indication after cancel :

LED1 (Red)	LED2 (Yellow)	LED3 (Green)
Lit	Lit	Not lit

NOTE : Indoor unit cannot be operated while this function is activated.

When this function is activated while indoor unit is operating, the operation will be stopped.

Operate indoor unit after the auto line correcting is finished.

Pressing the switch during detection cancels this function.

The record of auto line correcting can be confirmed in the following way:

Press the switch for more than 5 seconds.

LED will show the record of auto correcting for about 30 seconds as shown in the table below:

Number of blinks			Wiring line
LED1 (Red)	LED2 (Yellow)	LED3 (Green)	
Once	Once	Lit	Not corrected
3 times	3 times	Lit	Corrected

NOTE: Activate this function to confirm the correct wiring after replacing the outdoor control P.C. board.

(Previous records are deleted when the outdoor control P.C. board is replaced.)

The record cannot be shown if auto line correcting is not canceled (Refer to "How to activate this function").

11-3. CHANGING THE SET REFRIGERANT EVAPORATING TEMPERATURE

NOTE: If you lower the refrigerant evaporating temperature with the windows open, it may cause dew drop.

[How to change the refrigerant evaporating temperature]

- (1) Make sure there is no possibility of causing dew drop before making the setting.
- (2) Make the setting referring to the table below.

SW2 on the outdoor control P.C. board

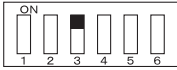
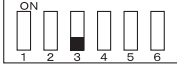
SW2	MXZ-3C24NA MXZ-3C30NA MXZ-4C36NA MXZ-5C42NA MXZ-2C20NA2 MXZ-3C24NA2 MXZ-3C30NA2 MXZ-4C36NA2 MXZ-2C20NAHZ MXZ-3C24NAHZ MXZ-3C30NAHZ MXZ-2C20NAHZ2 MXZ-3C24NAHZ2 MXZ-3C30NAHZ2	MXZ-3C24NA3 MXZ-3C30NA3 MXZ-4C36NA3 MXZ-5C42NA3 MXZ-2C20NA3 MXZ-2C20NAHZ3 MXZ-3C24NAHZ3 MXZ-3C30NAHZ3 MXZ-3C24NA4 MXZ-3C30NA4 MXZ-4C36NA4 MXZ-5C42NA4 MXZ-2C20NA4 MXZ-2C20NAHZ4 MXZ-3C24NAHZ4 MXZ-3C30NAHZ4
	44.6 °F or 48.2 °F (7 °C or 9 °C)	42.8 °F (6 °C)
	Normal control	

MXZ-3C24NA	MXZ-3C30NA	MXZ-4C36NA	MXZ-5C42NA	
MXZ-2C20NA2	MXZ-3C24NA2	MXZ-3C30NA2	MXZ-4C36NA2	MXZ-5C42NA2
MXZ-2C20NA3	MXZ-3C24NA3	MXZ-3C30NA3	MXZ-4C36NA3	MXZ-5C42NA3
MXZ-2C20NA4	MXZ-3C24NA4	MXZ-3C30NA4	MXZ-4C36NA4	MXZ-5C42NA4
MXZ-2C20NAHZ	MXZ-3C24NAHZ	MXZ-3C30NAHZ		
MXZ-2C20NAHZ2	MXZ-3C24NAHZ2	MXZ-3C30NAHZ2		
MXZ-2C20NAHZ3	MXZ-3C24NAHZ3	MXZ-3C30NAHZ3		
MXZ-2C20NAHZ4	MXZ-3C24NAHZ4	MXZ-3C30NAHZ4		

12-1. CAUTIONS ON TROUBLESHOOTING

1. Before troubleshooting, check the following:

- 1) Check the power supply voltage.
- 2) Check the indoor/outdoor connecting wire for miswiring.

2. Take care of the following during servicing.

- 1) Before servicing the air conditioner, be sure to turn OFF the unit first with the remote controller, and then after confirming the horizontal vane is closed, turn OFF the breaker and/or disconnect the power plug.
- 2) Be sure to turn OFF the power supply before removing the front panel, the cabinet, the top panel, and the outdoor control P.C. board.
- 3) When removing the electrical parts, be careful of the residual voltage of smoothing capacitor.
- 4) When removing the electronic control P.C. board, hold the edge of the board with care NOT to apply stress on the components.
- 5) When connecting or disconnecting the connectors, hold the connector housing. DO NOT pull the lead wires.

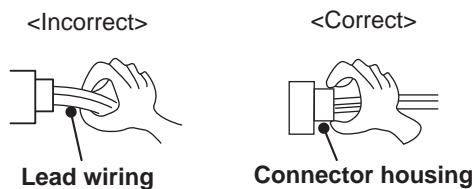

3. Troubleshooting procedure

- 1) Check if the OPERATION INDICATOR lamp on the indoor unit is blinking on and off to indicate an abnormality. To make sure, check how many times the OPERATIONAL INDICATOR lamp is blinking on and off before starting service work.
- 2) When the outdoor control P.C. board seems to be defective, check for disconnection of the copper foil pattern and burnt or discolored components.
- 3) When troubleshooting, refer to 12-2, 12-3 and 12-4.

12-2. FAILURE MODE RECALL FUNCTION

This air conditioner can memorize the abnormal condition which has occurred once.

Even though LED indication listed on the troubleshooting check table (12-4) disappears, the memorized failure details can be recalled.

1. Flow chart of failure mode recall function for the indoor/outdoor unit

Refer to the service manual of indoor unit.

2. Flow chart of the detailed outdoor unit failure mode recall function

Operational procedure

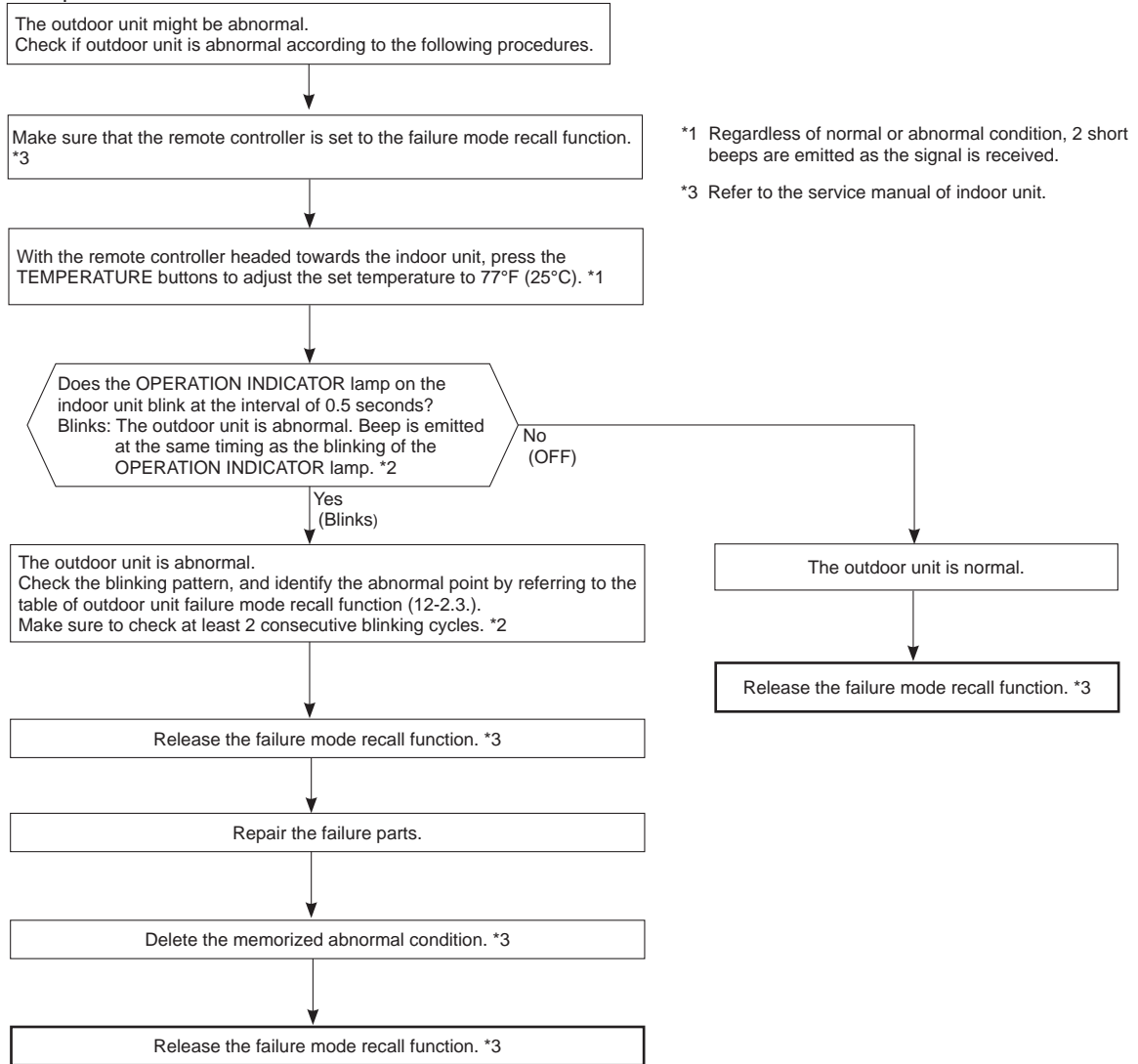

NOTE: 1. Make sure to release the failure mode recall function after it is set up, otherwise the unit cannot operate properly.
2. If the abnormal condition is not deleted from the memory, the last abnormal condition is kept memorized.

*2. Blinking pattern when outdoor unit is abnormal:

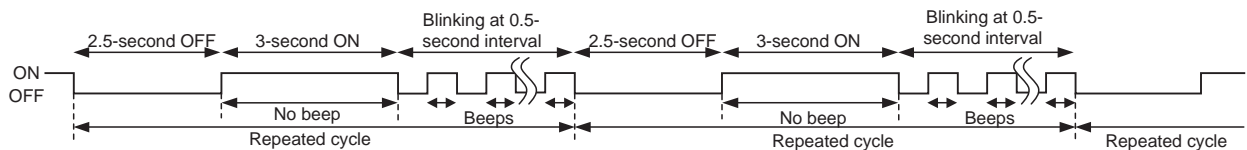

NOTE: Blinking patterns of this mode differ from the ones of TROUBLESHOOTING CHECK TABLE (12-4.).

3. Table of outdoor unit failure mode recall function

The left lamp of OPERATION INDICATOR lamp (Indoor unit)	Abnormal point (Failure mode/protection)	LED indication (Outdoor P.C. board)		Condition	Remedy	Indoor/outdoor unit failure mode recall function
		LED 1	LED 2			
OFF	None (Normal)	Lit	Lit	—	—	—
2-time blink	Outdoor power system	Lit	Lit	Overcurrent protection cut-out operates 3 consecutive times within 1 minute after the compressor gets started, or converter protection cut-out or bus-bar voltage protection cut-out operates 3 consecutive times within 3 minutes after startup.	<ul style="list-style-type: none"> • Check the connection of the compressor connecting wire. • Refer to 12-6. ⑥ "How to check inverter/compressor". • Check the stop valve. 	○
3-time blink	Discharge temperature thermistor	Lit	Once	A thermistor shorts or opens during compressor running.	<ul style="list-style-type: none"> • Refer to 12-6. ⑥ "Check of outdoor thermistors". 	○
	Defrost thermistor	Lit	Once			
	Ambient temperature thermistor	Lit	Twice			
	Fin temperature thermistor	Lit	3 times			
	P.C. board temperature thermistor	Lit	4 times			
Outdoor heat exchanger temperature thermistor	Lit	9 times		<ul style="list-style-type: none"> • Replace the outdoor control P.C. board. • Refer to 12-6. ⑥ "Check of outdoor thermistors". 		
4-time blink	Overcurrent	Once	Not lit	18 A (MXZ-2C20NA2, MXZ-2C20NA3, MXZ-2C20NA4)/21 A (MXZ-3C24/3C30/4C36NA, MXZ-3C24/3C30/4C36NA2, MXZ-3C24/3C30/4C36NA3, MXZ-3C24/3C30/4C36NA4)/28 A (MXZ-5C42NA, MXZ-2C20/3C24/3C30NAHZ, MXZ-5C42NA2, MXZ-2C20/3C24/3C30NAHZ2, MXZ-5C42NA3, MXZ-2C20/3C24/3C30NAHZ3, MXZ-5C42NA4, MXZ-2C20/3C24/3C30NAHZ4) current flows into power module.	<ul style="list-style-type: none"> • Reconnect compressor connector. • Refer to 12-6. ⑥ "How to check inverter/compressor". • Check the stop valve. 	—
5-time blink	Discharge temperature	Lit	Lit	The discharge temperature exceeds 239°F (MXZ-2C20NA2, MXZ-2C20NA3, MXZ-2C20NA4)/222.8°F (MXZ-3C24/3C30/4C36NA, MXZ-3C24/3C30/4C36NA2, MXZ-3C24/3C30/4C36NA3, MXZ-3C24/3C30/4C36NA4)/240.8°F (MXZ-2C20/3C24/3C30NAHZ, MXZ-5C42NA, MXZ-2C20/3C24/3C30NAHZ2, MXZ-5C42NA2, MXZ-2C20/3C24/3C30NAHZ3, MXZ-5C42NA3, MXZ-2C20/3C24/3C30NAHZ4, MXZ-5C42NA4) during operation. Compressor can restart if discharge temperature thermistor reads 176°F (MXZ-2C20NA2, MXZ-2C20NA3, MXZ-2C20NA4)/203°F (MXZ-3C24/3C30/4C36NA, MXZ-3C24/3C30/4C36NA2, MXZ-3C24/3C30/4C36NA3, MXZ-3C24/3C30/4C36NA4)/212°F (MXZ-2C20/3C24/3C30NAHZ, MXZ-5C42NA, MXZ-2C20/3C24/3C30NAHZ2, MXZ-5C42NA2, MXZ-2C20/3C24/3C30NAHZ3, MXZ-5C42NA3, MXZ-2C20/3C24/3C30NAHZ4, MXZ-5C42NA4) or less 3 minutes later.	<ul style="list-style-type: none"> • Check refrigerant circuit and refrigerant amount. • Refer to 12-6. ⑥ "Check of LEV". 	—
6-time blink	High pressure	Lit	Lit	The outdoor heat exchanger temperature exceeds 158°F during cooling or the indoor gas pipe temperature exceeds 158°F during heating.	<ul style="list-style-type: none"> • Check refrigerant circuit and refrigerant amount. • Check the stop valve. 	—
7-time blink	Fin temperature	3 times	Not lit	The fin temperature exceeds 190°F (MXZ-3C24/3C30/4C36NA, MXZ-2C20/3C24/3C30/4C36NA2, MXZ-2C20/3C24/3C30/4C36NA3, MXZ-2C20/3C24/3C30/4C36NA4)/192°F (MXZ-2C20/3C24/3C30NAHZ, MXZ-5C42NA, MXZ-2C20/3C24/3C30NAHZ2, MXZ-5C42NA2, MXZ-2C20/3C24/3C30NAHZ3, MXZ-5C42NA3, MXZ-2C20/3C24/3C30NAHZ4, MXZ-5C42NA4) during operation.	<ul style="list-style-type: none"> • Check around outdoor unit. • Check outdoor unit air passage. • Refer to 12-6. ⑥ "Check of outdoor fan motor". 	—
	P.C. board temperature	4 times	Not lit	The P.C. board temperature exceeds 152°F (MXZ-3C24/3C30/4C36NA, MXZ-2C20/3C24/3C30/4C36NA2, MXZ-2C20/3C24/3C30/4C36NA3, MXZ-2C20/3C24/3C30/4C36NA4)/189°F (MXZ-2C20/3C24/3C30NAHZ, MXZ-5C42NA, MXZ-2C20/3C24/3C30NAHZ2, MXZ-5C42NA2, MXZ-2C20/3C24/3C30NAHZ3, MXZ-5C42NA3, MXZ-2C20/3C24/3C30NAHZ4, MXZ-5C42NA4) during operation.		

NOTE: Blinking patterns of this mode differ from the ones of TROUBLESHOOTING CHECK TABLE (12-4.).

The left lamp of OPERATION INDICATOR lamp (Indoor unit)	Abnormal point (Failure mode/protection)	LED indication (Outdoor P.C. board)		Condition	Remedy	Indoor/outdoor unit failure mode recall function
		LED 1	LED 2			
8-time blink	Outdoor fan motor	Lit	Lit	A failure occurs 3 consecutive times within 30 seconds after the fan gets started.	• Refer to 12-6. © "Check of outdoor fan motor".	—
	4-way valve switching operation abnormality.	Lit	12 times	Connector of R.V. coil is disconnected, poorly connected or 4-way valve is faulty.	• Refer to 12-6. © "Check of R.V. coil". • Check the 4-way valve.	○
9-time blink	Outdoor control system	Lit	5 times	Nonvolatile memory data cannot be read properly.	• Replace the outdoor control P.C. board.	○
10-time blink	Low discharge temperature protection	Lit	Lit	The frequency of the compressor is kept 80 Hz or more and the discharge temperature is kept under 102.2°F for more than 20 minutes.	• Check refrigerant circuit and refrigerant amount. • Refer to 12-6. © "Check of LEV".	—
11-time blink	Communication error between P.C. boards	Lit	6 times	Communication error occurs between the outdoor control P.C. board and outdoor power P.C. board for more than 10 seconds.	• Check the connecting wire between outdoor control P.C. board and outdoor power P.C. board.	—
				The communication between boards protection cut-out operates 2 consecutive times.		○
	Current sensor	Lit	7 times	A short or open circuit is detected in the current sensor during compressor operating.	—	—
				Current sensor protection cut-out operates 2 consecutive times.		○
	Zero cross detecting circuit	5 times	Not lit	Zero cross signal cannot be detected while the compressor is operating.	• Check the connecting wire among outdoor control P.C. board and outdoor power P.C. board.	—
				The protection cut-out of the zero cross detecting circuit operates 10 consecutive times.		○
Converter	5 times	Not lit	A failure is detected in the operation of the converter during operation.	• Check the voltage of power supply. • Replace the outdoor power P.C. board.	—	
Bus-bar voltage	5 times	Not lit	The bus-bar voltage exceeds 400 V or falls to low level during compressor operating.	• Check the voltage of power supply. • Replace the outdoor power P.C. board or the outdoor control P.C. board.	—	
14-time blink	4-way valve switching operation abnormality.	Lit	12 times	Connector of R.V. coil is disconnected, poorly connected or 4-way valve is faulty.	• Refer to 12-6. © "Check of R.V. coil". • Check the 4-way valve.	○
15-time blink	LEV and drain pump	Lit	Lit	The indoor unit detects an abnormality in the LEV and drain pump.	• Refer to 12-6. © "Check of LEV". • Check the drain pump of the indoor unit.	—

12-3. INSTRUCTION OF TROUBLESHOOTING

- Check the indoor unit with referring to the indoor unit service manual, and confirm that there is any problem in the indoor unit. Then, check the outdoor unit with referring to this page.

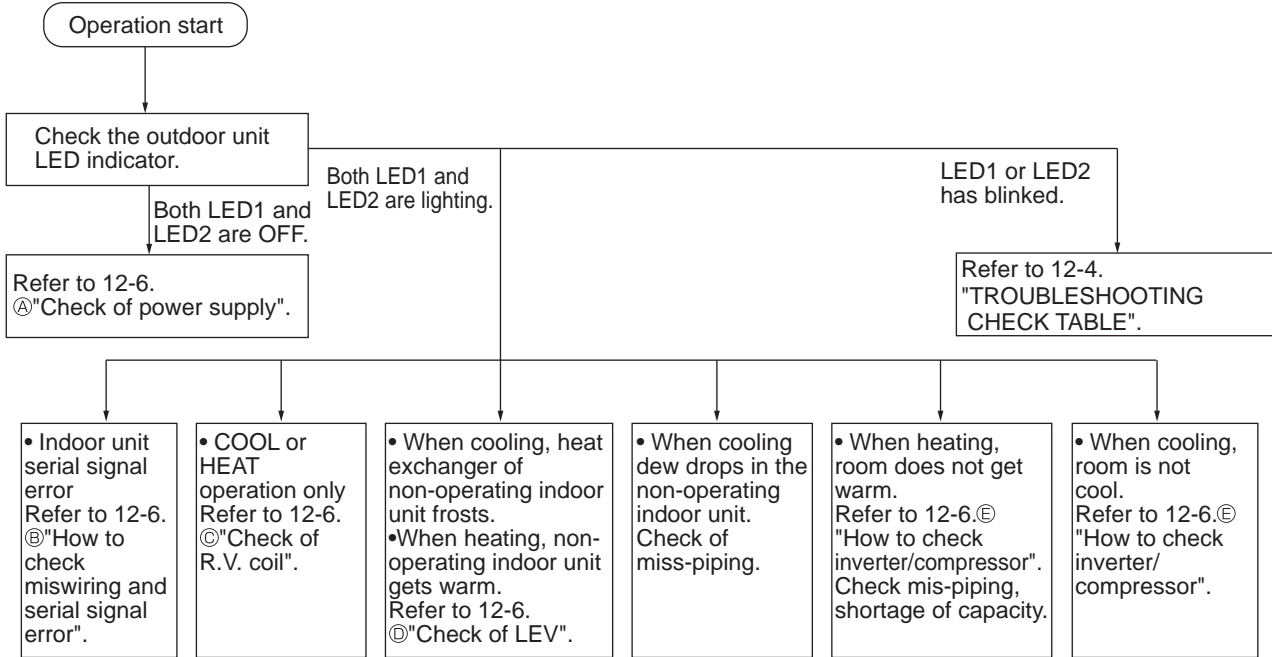

12-4. TROUBLESHOOTING CHECK TABLE

No.	Symptom	Indication		Abnormal point / Condition	Condition	Remedy
		LED1(Red)	LED2(Yellow)			
1	Outdoor unit does not operate.	Lit	Once	LEV and drain pump	The indoor unit detects an abnormality in the LEV and drain pump.	<ul style="list-style-type: none"> Refer to 12-6. ⑩ "Check of LEV". Check the drain pump of the indoor unit.
2		Lit	Twice	Outdoor power system	Overcurrent protection cut-out operates 3 consecutive times within 1 minute after the compressor gets started, or converter protection cut-out or bus-bar voltage protection cut-out operates 3 consecutive times within 3 minutes after startup.	<ul style="list-style-type: none"> Check the connection of the compressor connecting wire. Refer to 12-6. ⑩ "How to check inverter/compressor". Check the stop valve.
3		Lit	3 times	Discharge temperature thermistor	A short circuit is detected in the thermistor during operation, or an open circuit is detected in the thermistor after 10 minutes of compressor startup.	<ul style="list-style-type: none"> Refer to 12-6. ⑩ "Check of outdoor thermistors".
4		Lit	4 times	Fin temperature thermistor P. C. board temperature thermistor	A short or open circuit is detected in the thermistor during operation.	<ul style="list-style-type: none"> Refer to 12-6. ⑩ "Check of outdoor thermistors". Replace the outdoor control P.C. board.
5		Lit	5 times	Ambient temperature thermistor Outdoor heat exchanger temperature thermistor Defrost thermistor	A short or open circuit is detected in the thermistor during operation. A short circuit is detected in the thermistor during operation, or an open circuit is detected in the thermistor after 5 minutes (in cooling) and 10 minutes (in heating) of compressor startup. A short circuit is detected in the thermistor during operation, or an open circuit is detected in the thermistor after 5 minutes of compressor startup.	<ul style="list-style-type: none"> Refer to 12-6. ⑩ "Check of outdoor thermistors".
6		Lit	6 times	Zero cross detecting circuit (Outdoor control P.C. board)	Zero cross signal cannot be detected.	<ul style="list-style-type: none"> Replace the outdoor control P.C. board.
7		Lit	7 times	Outdoor control system	The nonvolatile memory data cannot be read properly.	<ul style="list-style-type: none"> Replace the outdoor control P.C. board.
8		Lit	8 times	Current sensor	Current sensor protection cut-out operates 2 consecutive times.	<ul style="list-style-type: none"> Replace the outdoor power P.C. board.
9		Lit	11 times	Communication error between P.C. boards M-NET communication error	The communication protection cut-out between boards operates 2 consecutive times. M-NET adapter P.C. board detects an abnormality in the communication error.	<ul style="list-style-type: none"> Check the connecting wire between outdoor control P.C. board and outdoor power P.C. board. Check the connecting wire between M-NET adapter P.C. board and outdoor control P.C. board, or terminal bed.
10		Lit	12 times	Zero cross detecting circuit (Outdoor power P.C. board)	The protection cut-out of the zero cross detecting circuit operates 10 consecutive times.	<ul style="list-style-type: none"> Replace the outdoor power P.C. board.
11		Lit	13 times	Current sensor	A short or open circuit is detected in the input current detection circuit during operation.	<ul style="list-style-type: none"> Replace the outdoor power P.C. board.
12		Lit	14 times	Voltage sensor	A short or open circuit is detected in the input voltage detection circuit during operation.	<ul style="list-style-type: none"> Replace the outdoor power P.C. board.
13		Lit	15 times	Relay operation	No relay operation is detected during operation.	<ul style="list-style-type: none"> Replace the outdoor power P.C. board.
14		Lit	21 times	4-way valve	Connector of R.V. coil is disconnected, poorly connected or 4-way valve is faulty.	<ul style="list-style-type: none"> Refer to 12-6. ⑩ "Check of R.V. coil". Check the 4-way valve.
15	'Outdoor unit stops and restarts 3 minutes later' is repeated.	Twice	Not lit	IPM protection	Overcurrent is detected after 30 seconds of compressor startup.	<ul style="list-style-type: none"> Reconnect compressor connector. Refer to 12-6. ⑩ "How to check inverter/compressor".
16				Lock protection	Overcurrent is detected within 30 seconds of compressor startup.	<ul style="list-style-type: none"> Check the stop valve. Check the power module (PAM module).
16		3 times	Not lit	Discharge temperature protection	The discharge temperature exceeds 239°F (MXZ-2C20NA2, MXZ-2C20NA3, MXZ-2C20NA4)/222.8°F (MXZ-3C24/3C30/4C36NA, MXZ-3C24/3C30/4C36NA2, MXZ-3C24/3C30/4C36NA3, MXZ-3C24/3C30/4C36NA4)/240.8°F (MXZ-2C20/3C24/3C30NAHZ, MXZ-5C42NA, MXZ-2C20/3C24/3C30NAHZ2, MXZ-5C42NA2, MXZ-2C20/3C24/3C30NAHZ3, MXZ-5C42NA3, MXZ-2C20/3C24/3C30NAHZ4, MXZ-5C42NA4) during operation. Compressor can restart if discharge temperature thermistor reads 176°F (MXZ-2C20NA2, MXZ-2C20NA3, MXZ-2C20NA4)/203°F (MXZ-3C24/3C30/4C36NA, MXZ-3C24/3C30/4C36NA2, MXZ-3C24/3C30/4C36NA3, MXZ-3C24/3C30/4C36NA4)/212°F (MXZ-2C20/3C24/3C30NAHZ, MXZ-5C42NA, MXZ-2C20/3C24/3C30NAHZ2, MXZ-5C42NA2, MXZ-2C20/3C24/3C30NAHZ3, MXZ-5C42NA3, MXZ-2C20/3C24/3C30NAHZ4, MXZ-5C42NA4) or less 3 minutes later.	<ul style="list-style-type: none"> Check the amount of gas and refrigerant circuit. Refer to 12-6. ⑩ "Check of LEV".
17					4 times	Not lit

No.	Symptom	Indication		Abnormal point / Condition	Condition	Remedy		
		LED1(Red)	LED2(Yellow)					
18	'Outdoor unit stops and restarts 3 minutes later' is repeated.	5 times	Not lit	High pressure protection	High pressure is detected with the high pressure switch (HPS) during operation.	<ul style="list-style-type: none"> • Check around of gas and the refrigerant circuit. • Check the stop valve. 		
19					6 times		Not lit	Pre-heating protection
20		8 times	Not lit	Converter protection	A failure is detected in the operation of the converter during operation.	<ul style="list-style-type: none"> • Replace the outdoor power P.C. board. 		
21		9 times	Not lit	Bus-bar voltage protection	The bus-bar voltage exceeds 400 V or falls to low level during compressor operating.	<ul style="list-style-type: none"> • Check the voltage of power supply. • Replace the outdoor power P.C. board or the outdoor control P.C. board. • Refer to 12-6. ④ "Check of bus-bar voltage". 		
22		11 times	Not lit	Low out side temperature protection(cooling)	The ambient became 10.4°F or less.	—		
23				13 times	Not lit		Low out side temperature protection(Heating)	The ambient became 1.4°F or less. (MXZ-3C24/3C30/4C36/5C42NA, MXZ-3C24/3C30/4C36/5C42NA2, MXZ-3C24/3C30/4C36/5C42NA3, MXZ-3C24/3C30/4C36/5C42NA4)
								The ambient became -18°F or less. (MXZ-2C20/3C24/3C30NAHZ, MXZ-2C20/3C24/3C30NAHZ2, MXZ-2C20/3C24/3C30NAHZ3, MXZ-2C20/3C24/3C30NAHZ4)
24		14 times	Not lit	Outdoor fan motor	A failure occurs 3 consecutive times within 30 seconds after the fan gets started.	<ul style="list-style-type: none"> • Refer to 12-6. ⑥ "Check of outdoor fan motor". 		
25		Lit	8 times	4-way valve switching operation	Connector of R.V. coil is disconnected, poorly connected or 4-way valve is faulty.	<ul style="list-style-type: none"> • Refer to 12-6. ⑦ "Check of R.V. coil". • Check the 4-way valve. 		
26		Lit	11 times	Current sensor protection	A short or open circuit is detected in the current sensor during compressor operating.	<ul style="list-style-type: none"> • Replace the outdoor power P.C. board. 		
27		Lit	12 times	Communication between P.C. boards protection	Communication error occurs between the outdoor control P.C. board and outdoor power P.C. board for more than 10 seconds.	<ul style="list-style-type: none"> • Check the connecting wire between outdoor control P.C. board and outdoor power P.C. board. 		
28	Once	Lit	Zero cross detecting circuit protection (Outdoor power P.C. board)	Zero cross signal cannot be detected while the compressor is operating.	<ul style="list-style-type: none"> • Replace the outdoor power P.C. board. 			
29	Twice	Lit	Primary current protection	The input current exceeds 15.0 A (MXZ-2C20NA2, MXZ-2C20NA3, MXZ-2C20NA4)/18.4 A (MXZ-3C24/3C30/4C36NA, MXZ-3C24/3C30/4C36NA2, MXZ-3C24/3C30/4C36NA3, MXZ-3C24/3C30/4C36NA4)/26.8 A (MXZ-2C20/3C24/3C30NAHZ, MXZ-5C42NA, MXZ-2C20/3C24/3C30NAHZ2, MXZ-5C42NA2, MXZ-2C20/3C24/3C30NAHZ3, MXZ-5C42NA3, MXZ-2C20/3C24/3C30NAHZ4, MXZ-5C42NA4).	<ul style="list-style-type: none"> • These symptoms do not mean any abnormality of the product, but check the following points. • Check if indoor filters are clogged. • Check if refrigerant is short. • Check if indoor/outdoor unit air circulation is short cycled. 			
30			High pressure protection	The indoor gas pipe temperature exceeds 113°F during heating.				
31	3 times	Lit	Defrosting in cooling	The indoor gas pipe temperature falls 37.4°F or below during cooling.	<ul style="list-style-type: none"> • Check refrigerant circuit and refrigerant amount. • Refer to 12-6. ⑧ "Check of LEV". • Refer to 12-6. ⑨ "Check of outdoor thermistors". 			
32	4 times	Lit	Discharge temperature protection	The frequency of the compressor is kept 80 Hz or more and the discharge temperature is kept under 122°F(COOL mode)/104°F(HEAT mode) for more than 40 minutes.				
33	5 times	Lit	Low discharge temperature protection	The frequency of the compressor is kept 80 Hz or more and the discharge temperature is kept under 102.2°F for more than 20 minutes.	<ul style="list-style-type: none"> • Refer to 12-6. ⑩ "Check of LEV". • Check refrigerant circuit and refrigerant amount. 			
34	7 times	Lit	Cooling high pressure protection	The outdoor heat exchanger temperature exceeds 136.4°F during operation.	<ul style="list-style-type: none"> • This symptom does not mean any abnormality of the product, but check the following points. • Check if indoor filters are clogged. • Check if refrigerant is short. • Check if indoor/outdoor unit air circulation is short cycled. 			
35	11 times	Lit	High → Low Pressure bypass valve Cooling evaporating temperature drop prevention control	During cooling operation, the temperature of indoor heat exchanger becomes 37.4°F or less within 1 hour after the compressor starts running, or it becomes less than 53.6°F - 60.8°F* later than that. * It depends on the difference between the set temperature and the room temperature. (MXZ-2C20/3C24/3C30NAHZ, MXZ-5C42NA, MXZ-2C20/3C24/3C30NAHZ2, MXZ-5C42NA2, MXZ-2C20/3C24/3C30NAHZ3, MXZ-5C42NA3, MXZ-2C20/3C24/3C30NAHZ4, MXZ-5C42NA4)	<ul style="list-style-type: none"> • This symptom does not mean any abnormality of the product, but check the following points. • Check the indoor filters are not clogged. • Check there is sufficient refrigerant. • Check the indoor/outdoor unit air circulation is not short cycled. 			
36			M-NET communication error	M-NET adapter P.C. board detects an abnormality in the communication error.	<ul style="list-style-type: none"> • Check the connecting wire between M-NET adapter P.C. board and outdoor control P.C. board, or terminal block. 			

No.	Symptom	Indication		Abnormal point / Condition	Condition	Remedy
		LED1(Red)	LED2(Yellow)			
35	Outdoor unit operates normally.	7 times	Lit	High → Low pressure bypass valve High pressure protection control at startup of heating operation	The room temperature is 75.2°F or more when 1 or 2 unit(s) start(s) the heating operation. (MXZ-2C20/3C24/3C30NAHZ, MXZ-5C42NA, MXZ-2C20/3C24/3C30NAHZ2, MXZ-5C42NA2, MXZ-2C20/3C24/3C30NAHZ3, MXZ-5C42NA3, MXZ-2C20/3C24/3C30NAHZ4, MXZ-5C42NA4)	This symptom does not mean any abnormality of the product.
				High → Low pressure bypass valve Compressor oil tempering control at startup of heating operation	Both the following are true: • The outside temperature is 28.4°F or less when the heating operation is started. • [(Discharge temperature) - (Indoor heat exchanger temperature)] < 9°F (MXZ-2C20/3C24/3C30NAHZ, MXZ-5C42NA, MXZ-2C20/3C24/3C30NAHZ2, MXZ-5C42NA2, MXZ-2C20/3C24/3C30NAHZ3, MXZ-5C42NA3, MXZ-2C20/3C24/3C30NAHZ4, MXZ-5C42NA4)	
		8 times	Lit	Cooling evaporating temperature protection	During cooling operation, the temperature of indoor heat exchanger becomes 44.6°F - 51.8°F* or less within 1 hour after the compressor starts running, or it becomes 48.2°F - 62.6°F* or less later than that. * It depends on the indoor unit type/model or the difference between the set temperature and the room temperature.	This symptom does not mean any abnormality of the product.
		9 times	Lit	Inverter check mode	The unit is operated with emergency operation switch.	
36		Lit	Lit	Normal	—	—

NOTE: 1. The location of LED is illustrated at the right figure. Refer to 12-7.1.
2. LED is lit during normal operation.

The blinking frequency shows the number of times the LED blinks after every 2.5-second OFF.
(Example) When the blinking frequency is "2".

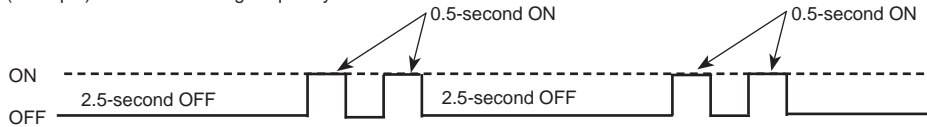

Outdoor control P.C. board
(Parts side)

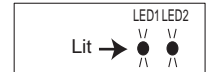

12-5. TROUBLESHOOTING CRITERION OF MAIN PARTS

MXZ-3C24NA	MXZ-3C30NA	MXZ-4C36NA	MXZ-5C42NA	
MXZ-2C20NA2	MXZ-3C24NA2	MXZ-3C30NA2	MXZ-4C36NA2	MXZ-5C42NA2
MXZ-2C20NA3	MXZ-3C24NA3	MXZ-3C30NA3	MXZ-4C36NA3	MXZ-5C42NA3
MXZ-2C20NA4	MXZ-3C24NA4	MXZ-3C30NA4	MXZ-4C36NA4	MXZ-5C42NA4
MXZ-2C20NAHZ	MXZ-3C24NAHZ	MXZ-3C30NAHZ		
MXZ-2C20NAHZ2	MXZ-3C24NAHZ2	MXZ-3C30NAHZ2		
MXZ-2C20NAHZ3	MXZ-3C24NAHZ3	MXZ-3C30NAHZ3		
MXZ-2C20NAHZ4	MXZ-3C24NAHZ4	MXZ-3C30NAHZ4		

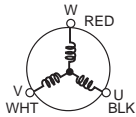
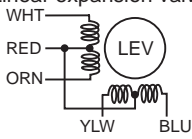
Part name	Check method and criterion																																																
Defrost thermistor (RT61) Fin temperature thermistor (RT64) Ambient temperature thermistor (RT65) Outdoor heat exchanger temperature thermistor (RT68)	Measure the resistance with a multimeter. Refer to 12-7. "TEST POINT DIAGRAM AND VOLTAGE", 1. "Outdoor control P.C.board", 2. "Outdoor power P.C. board", for the chart of thermistor.																																																
Discharge temperature thermistor (RT62)	Measure the resistance with a multimeter. Before measurement, hold the thermistor with your hands to warm it up. Refer to 12-7. "TEST POINT DIAGRAM AND VOLTAGE", 1. "Outdoor control P.C. board" for the chart of thermistor.																																																
Compressor 	Measure the resistance between terminals using a multimeter. (Winding temperature: 14°F - 104°F) <table border="1" style="width: 100%; text-align: center;"> <thead> <tr> <th colspan="4">Normal (Each phase)</th> </tr> </thead> <tbody> <tr> <td>MXZ-2C20NA2</td> <td>MXZ-3C24NA</td> <td>MXZ-3C30NA</td> <td>MXZ-4C36NA</td> </tr> <tr> <td>MXZ-2C20NA3</td> <td>MXZ-3C24NA2</td> <td>MXZ-3C30NA2</td> <td>MXZ-4C36NA2</td> </tr> <tr> <td>MXZ-2C20NA4</td> <td>MXZ-3C24NA3</td> <td>MXZ-3C30NA3</td> <td>MXZ-4C36NA3</td> </tr> <tr> <td></td> <td>MXZ-3C24NA4</td> <td>MXZ-3C30NA4</td> <td>MXZ-4C36NA4</td> </tr> <tr> <td colspan="2">0.63 kΩ - 0.78 kΩ</td> <td colspan="2">0.83 Ω - 1.03 Ω</td> </tr> </tbody> </table> Measure the resistance between terminals using a multimeter. (Winding temperature: 14°F - 104°F) <table border="1" style="width: 100%; text-align: center;"> <thead> <tr> <th colspan="4">Normal (Each phase)</th> </tr> </thead> <tbody> <tr> <td>MXZ-5C42NA</td> <td>MXZ-2C20NAHZ</td> <td>MXZ-3C24NAHZ</td> <td>MXZ-3C30NAHZ</td> </tr> <tr> <td>MXZ-5C42NA2</td> <td>MXZ-2C20NAHZ2</td> <td>MXZ-3C24NAHZ2</td> <td>MXZ-3C30NAHZ2</td> </tr> <tr> <td>MXZ-5C42NA3</td> <td>MXZ-2C20NAHZ3</td> <td>MXZ-3C24NAHZ3</td> <td>MXZ-3C30NAHZ3</td> </tr> <tr> <td>MXZ-5C42NA4</td> <td>MXZ-2C20NAHZ4</td> <td>MXZ-3C24NAHZ4</td> <td>MXZ-3C30NAHZ4</td> </tr> <tr> <td colspan="4">0.77 Ω - 0.95 Ω</td> </tr> </tbody> </table>	Normal (Each phase)				MXZ-2C20NA2	MXZ-3C24NA	MXZ-3C30NA	MXZ-4C36NA	MXZ-2C20NA3	MXZ-3C24NA2	MXZ-3C30NA2	MXZ-4C36NA2	MXZ-2C20NA4	MXZ-3C24NA3	MXZ-3C30NA3	MXZ-4C36NA3		MXZ-3C24NA4	MXZ-3C30NA4	MXZ-4C36NA4	0.63 kΩ - 0.78 kΩ		0.83 Ω - 1.03 Ω		Normal (Each phase)				MXZ-5C42NA	MXZ-2C20NAHZ	MXZ-3C24NAHZ	MXZ-3C30NAHZ	MXZ-5C42NA2	MXZ-2C20NAHZ2	MXZ-3C24NAHZ2	MXZ-3C30NAHZ2	MXZ-5C42NA3	MXZ-2C20NAHZ3	MXZ-3C24NAHZ3	MXZ-3C30NAHZ3	MXZ-5C42NA4	MXZ-2C20NAHZ4	MXZ-3C24NAHZ4	MXZ-3C30NAHZ4	0.77 Ω - 0.95 Ω			
Normal (Each phase)																																																	
MXZ-2C20NA2	MXZ-3C24NA	MXZ-3C30NA	MXZ-4C36NA																																														
MXZ-2C20NA3	MXZ-3C24NA2	MXZ-3C30NA2	MXZ-4C36NA2																																														
MXZ-2C20NA4	MXZ-3C24NA3	MXZ-3C30NA3	MXZ-4C36NA3																																														
	MXZ-3C24NA4	MXZ-3C30NA4	MXZ-4C36NA4																																														
0.63 kΩ - 0.78 kΩ		0.83 Ω - 1.03 Ω																																															
Normal (Each phase)																																																	
MXZ-5C42NA	MXZ-2C20NAHZ	MXZ-3C24NAHZ	MXZ-3C30NAHZ																																														
MXZ-5C42NA2	MXZ-2C20NAHZ2	MXZ-3C24NAHZ2	MXZ-3C30NAHZ2																																														
MXZ-5C42NA3	MXZ-2C20NAHZ3	MXZ-3C24NAHZ3	MXZ-3C30NAHZ3																																														
MXZ-5C42NA4	MXZ-2C20NAHZ4	MXZ-3C24NAHZ4	MXZ-3C30NAHZ4																																														
0.77 Ω - 0.95 Ω																																																	
Outdoor fan motor	• Refer to 12-6. ©																																																
R.V. coil	Measure the resistance using a multimeter. (Part temperature: 14°F - 104°F) <table border="1" style="width: 100%; text-align: center;"> <thead> <tr> <th colspan="4">Normal (Each phase)</th> </tr> </thead> <tbody> <tr> <td>MXZ-2C20NA2</td> <td>MXZ-3C24NA</td> <td>MXZ-3C30NA</td> <td>MXZ-4C36NA</td> </tr> <tr> <td>MXZ-2C20NA3</td> <td>MXZ-3C24NA2</td> <td>MXZ-3C30NA2</td> <td>MXZ-4C36NA2</td> </tr> <tr> <td>MXZ-2C20NA4</td> <td>MXZ-3C24NA3</td> <td>MXZ-3C30NA3</td> <td>MXZ-4C36NA3</td> </tr> <tr> <td></td> <td>MXZ-3C24NA4</td> <td>MXZ-3C30NA4</td> <td>MXZ-4C36NA4</td> </tr> <tr> <td colspan="2">1.26 kΩ - 1.62 kΩ</td> <td colspan="2">1.20 kΩ - 1.77 kΩ</td> </tr> </tbody> </table> Measure the resistance using a multimeter. (Part temperature: 14°F - 104°F) <table border="1" style="width: 100%; text-align: center;"> <thead> <tr> <th colspan="4">Normal (Each phase)</th> </tr> </thead> <tbody> <tr> <td>MXZ-5C42NA</td> <td>MXZ-2C20NAHZ</td> <td>MXZ-3C24NAHZ</td> <td>MXZ-3C30NAHZ</td> </tr> <tr> <td>MXZ-5C42NA2</td> <td>MXZ-2C20NAHZ2</td> <td>MXZ-3C24NAHZ2</td> <td>MXZ-3C30NAHZ2</td> </tr> <tr> <td>MXZ-5C42NA3</td> <td>MXZ-2C20NAHZ3</td> <td>MXZ-3C24NAHZ3</td> <td>MXZ-3C30NAHZ3</td> </tr> <tr> <td>MXZ-5C42NA4</td> <td>MXZ-2C20NAHZ4</td> <td>MXZ-3C24NAHZ4</td> <td>MXZ-3C30NAHZ4</td> </tr> <tr> <td colspan="4">1.24 kΩ - 1.86 kΩ</td> </tr> </tbody> </table>	Normal (Each phase)				MXZ-2C20NA2	MXZ-3C24NA	MXZ-3C30NA	MXZ-4C36NA	MXZ-2C20NA3	MXZ-3C24NA2	MXZ-3C30NA2	MXZ-4C36NA2	MXZ-2C20NA4	MXZ-3C24NA3	MXZ-3C30NA3	MXZ-4C36NA3		MXZ-3C24NA4	MXZ-3C30NA4	MXZ-4C36NA4	1.26 kΩ - 1.62 kΩ		1.20 kΩ - 1.77 kΩ		Normal (Each phase)				MXZ-5C42NA	MXZ-2C20NAHZ	MXZ-3C24NAHZ	MXZ-3C30NAHZ	MXZ-5C42NA2	MXZ-2C20NAHZ2	MXZ-3C24NAHZ2	MXZ-3C30NAHZ2	MXZ-5C42NA3	MXZ-2C20NAHZ3	MXZ-3C24NAHZ3	MXZ-3C30NAHZ3	MXZ-5C42NA4	MXZ-2C20NAHZ4	MXZ-3C24NAHZ4	MXZ-3C30NAHZ4	1.24 kΩ - 1.86 kΩ			
Normal (Each phase)																																																	
MXZ-2C20NA2	MXZ-3C24NA	MXZ-3C30NA	MXZ-4C36NA																																														
MXZ-2C20NA3	MXZ-3C24NA2	MXZ-3C30NA2	MXZ-4C36NA2																																														
MXZ-2C20NA4	MXZ-3C24NA3	MXZ-3C30NA3	MXZ-4C36NA3																																														
	MXZ-3C24NA4	MXZ-3C30NA4	MXZ-4C36NA4																																														
1.26 kΩ - 1.62 kΩ		1.20 kΩ - 1.77 kΩ																																															
Normal (Each phase)																																																	
MXZ-5C42NA	MXZ-2C20NAHZ	MXZ-3C24NAHZ	MXZ-3C30NAHZ																																														
MXZ-5C42NA2	MXZ-2C20NAHZ2	MXZ-3C24NAHZ2	MXZ-3C30NAHZ2																																														
MXZ-5C42NA3	MXZ-2C20NAHZ3	MXZ-3C24NAHZ3	MXZ-3C30NAHZ3																																														
MXZ-5C42NA4	MXZ-2C20NAHZ4	MXZ-3C24NAHZ4	MXZ-3C30NAHZ4																																														
1.24 kΩ - 1.86 kΩ																																																	
2-way valve solenoid coil	Measure the resistance using a multimeter. (Part temperature: 14°F - 104°F) <table border="1" style="width: 100%; text-align: center;"> <thead> <tr> <th colspan="4">Normal</th> </tr> </thead> <tbody> <tr> <td>MXZ-5C42NA</td> <td>MXZ-2C20NAHZ</td> <td>MXZ-3C24NAHZ</td> <td>MXZ-3C30NAHZ</td> </tr> <tr> <td>MXZ-5C42NA2</td> <td>MXZ-2C20NAHZ2</td> <td>MXZ-3C24NAHZ2</td> <td>MXZ-3C30NAHZ2</td> </tr> <tr> <td>MXZ-5C42NA3</td> <td>MXZ-2C20NAHZ3</td> <td>MXZ-3C24NAHZ3</td> <td>MXZ-3C30NAHZ3</td> </tr> <tr> <td>MXZ-5C42NA4</td> <td>MXZ-2C20NAHZ4</td> <td>MXZ-3C24NAHZ4</td> <td>MXZ-3C30NAHZ4</td> </tr> <tr> <td colspan="4">0.97 kΩ - 1.37 kΩ</td> </tr> </tbody> </table>	Normal				MXZ-5C42NA	MXZ-2C20NAHZ	MXZ-3C24NAHZ	MXZ-3C30NAHZ	MXZ-5C42NA2	MXZ-2C20NAHZ2	MXZ-3C24NAHZ2	MXZ-3C30NAHZ2	MXZ-5C42NA3	MXZ-2C20NAHZ3	MXZ-3C24NAHZ3	MXZ-3C30NAHZ3	MXZ-5C42NA4	MXZ-2C20NAHZ4	MXZ-3C24NAHZ4	MXZ-3C30NAHZ4	0.97 kΩ - 1.37 kΩ																											
Normal																																																	
MXZ-5C42NA	MXZ-2C20NAHZ	MXZ-3C24NAHZ	MXZ-3C30NAHZ																																														
MXZ-5C42NA2	MXZ-2C20NAHZ2	MXZ-3C24NAHZ2	MXZ-3C30NAHZ2																																														
MXZ-5C42NA3	MXZ-2C20NAHZ3	MXZ-3C24NAHZ3	MXZ-3C30NAHZ3																																														
MXZ-5C42NA4	MXZ-2C20NAHZ4	MXZ-3C24NAHZ4	MXZ-3C30NAHZ4																																														
0.97 kΩ - 1.37 kΩ																																																	
Linear expansion valve 	Measure the resistance using a multimeter. (Part temperature: 14°F - 104°F) <table border="1" style="width: 100%; text-align: center;"> <thead> <tr> <th>Color of lead wire</th> <th>Normal</th> </tr> </thead> <tbody> <tr> <td>WHT - RED</td> <td rowspan="4">37.4 Ω - 53.9 Ω</td> </tr> <tr> <td>RED - ORN</td> </tr> <tr> <td>YLW - RED</td> </tr> <tr> <td>RED - BLU</td> </tr> </tbody> </table>	Color of lead wire	Normal	WHT - RED	37.4 Ω - 53.9 Ω	RED - ORN	YLW - RED	RED - BLU																																									
Color of lead wire	Normal																																																
WHT - RED	37.4 Ω - 53.9 Ω																																																
RED - ORN																																																	
YLW - RED																																																	
RED - BLU																																																	

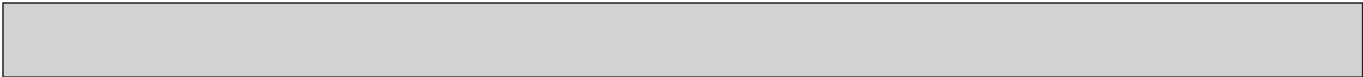

Part name	Check method and criterion		
High pressure switch(HPS)		Pressure	Normal
	HPS	537 ± 22 PSIG	Close
		696 ⁺⁷ / ₋₁₅ PSIG	Open
Defrost heater	Measure the resistance using a multimeter. (Part temperature: 14°F - 104°F)		
	Normal		
	MXZ-2C20NAHZ	MXZ-3C24NAHZ	MXZ-3C30NAHZ
	MXZ-2C20NAHZ2	MXZ-3C24NAHZ2	MXZ-3C30NAHZ2
	MXZ-2C20NAHZ3	MXZ-3C24NAHZ3	MXZ-3C30NAHZ3
MXZ-2C20NAHZ4	MXZ-3C24NAHZ4	MXZ-3C30NAHZ4	
0.35 kΩ - 0.50 kΩ			

12-6. TROUBLESHOOTING FLOW

Outdoor unit does not operate.

Ⓐ Check of power supply

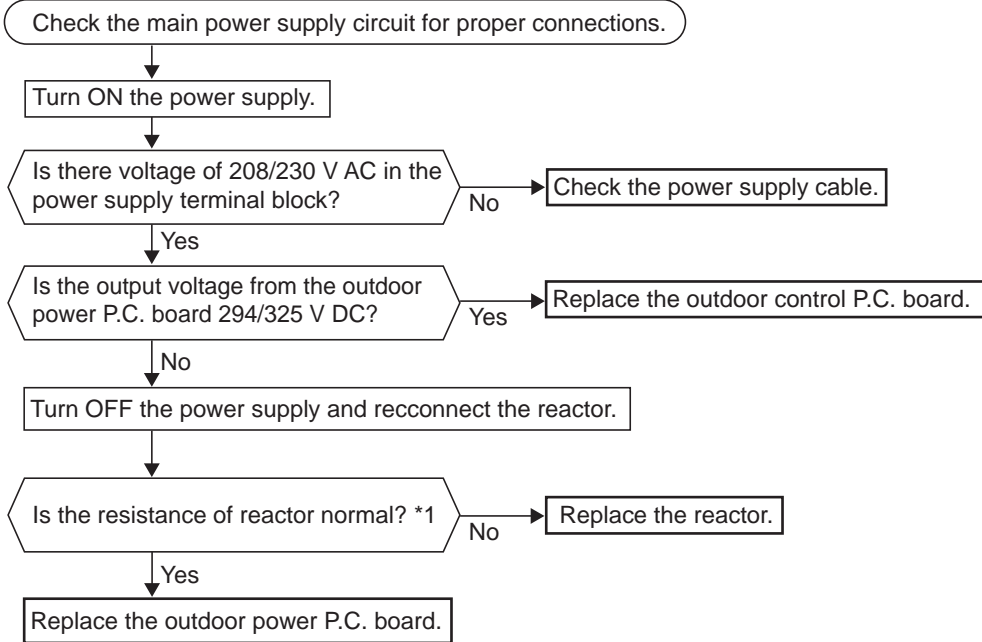

*1 MXZ-3C24NA MXZ-3C30NA MXZ-4C36NA
 MXZ-2C20NA2 MXZ-3C24NA2 MXZ-3C30NA2 MXZ-4C36NA2
 MXZ-2C20NA3 MXZ-3C24NA3 MXZ-3C30NA3 MXZ-4C36NA3
 MXZ-2C20NA4 MXZ-3C24NA4 MXZ-3C30NA4 MXZ-4C36NA4

Measuring points	Resistance
pin 1 – pin 2	1 Ω or less
pin 3 – pin 4	1 Ω or less

MXZ-5C42NA MXZ-5C42NA2 MXZ-5C42NA3 MXZ-5C42NA4
 MXZ-2C20NAHZ MXZ-3C24NAHZ MXZ-3C30NAHZ
 MXZ-2C20NAHZ2 MXZ-3C24NAHZ2 MXZ-3C30NAHZ2
 MXZ-2C20NAHZ3 MXZ-3C24NAHZ3 MXZ-3C30NAHZ3
 MXZ-2C20NAHZ4 MXZ-3C24NAHZ4 MXZ-3C30NAHZ4

Measuring points	Resistance
–	1 Ω or less

- When unit cannot operate neither by the remote controller nor by EMERGENCY OPERATION switch. Indoor unit does not operate.
- When OPERATION INDICATOR lamp blinks ON and OFF in every 0.5-second. Outdoor unit does not operate.

Ⓑ How to check miswiring and serial signal error (when outdoor unit does not work)

LED indication for communication status

Communication status is indicated by the LED.

Unit status

Blinking: normal communication
Lit: abnormal communication or not connected

Pattern 1 and 2 is repeatedly displayed alternately. Each pattern is displayed for 15 seconds.

NOTE: "Lit" in the table below does not indicate abnormal communication.

Outdoor control P.C. board

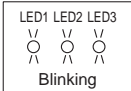

Pattern	LED 1	LED 2	LED 3
1	Unit A status	Unit B status	Lit
2	Unit C status	Unit D status	Not lit
3	Unit E status	—	Blinking

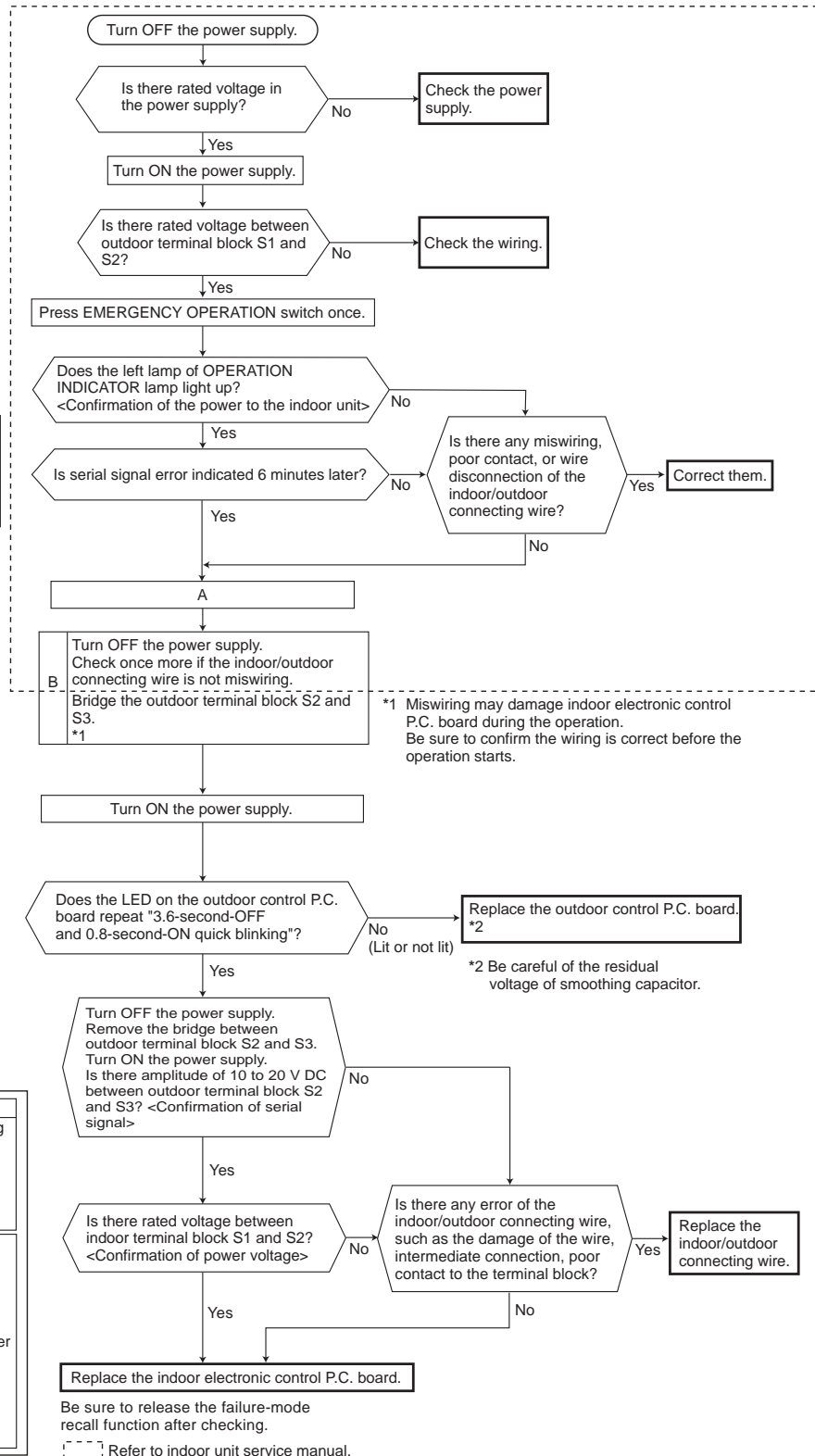

The cooling operation or heating operation does not operate.

© Check of R.V. coil

• When cooling operation does not work,

1. Disconnect the lead wire leading to the compressor.
2. 3 minutes after turning ON the power supply, start EMERGENCY OPERATION in COOL mode.

CNAC CN712	Outdoor control P.C. board
CNAC2	Outdoor power P.C. board

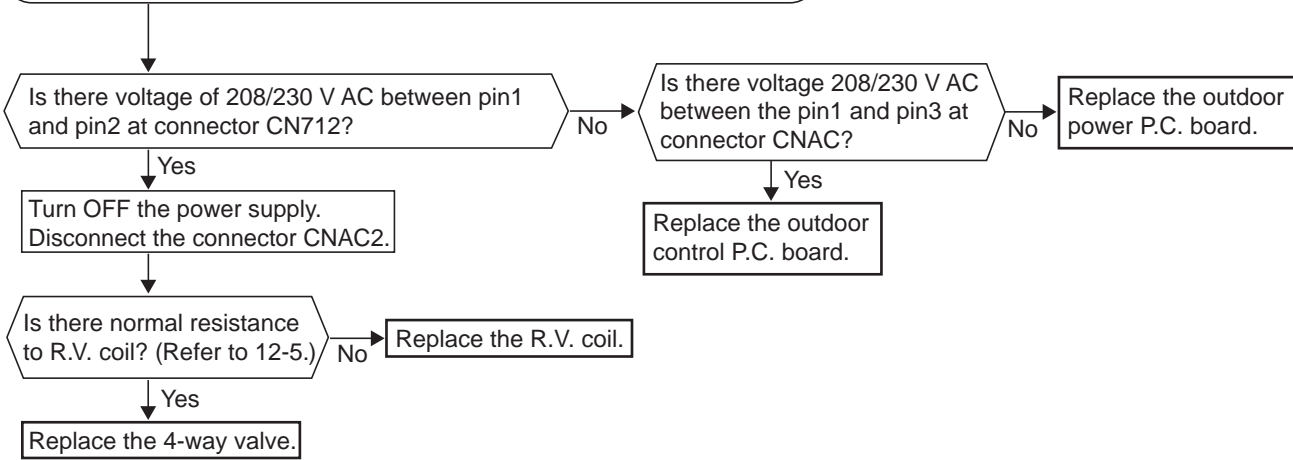

• When heating operation does not work,

1. Disconnect the lead wire leading to the compressor.
2. 3 minutes after turning ON the power supply, start EMERGENCY OPERATION in HEAT mode.

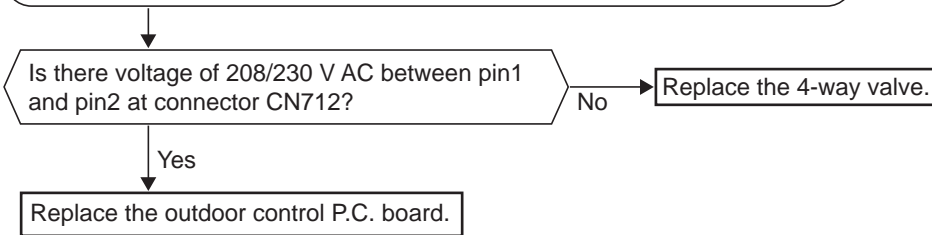

- When cooling, heat exchanger of non-operating indoor unit frosts.
- When heating, non-operating indoor unit gets warm.

④ **Check of LEV**

Turn ON the power supply to the outdoor unit after checking LEV coil is mounted to the LEV body securely.

Is "click - click" sound heard?
Or, do you feel vibration of LEV coil with your hand?

Yes → Normal

No

Disconnect the connectors.

MXZ-2C

CN791: LEV A, CN792: LEV B,
CN797: LEV R (**MXZ-2C20NA2, MXZ-2C20NA3, MXZ-2C20NA4**)

MXZ-3C/4C/5C

CN791: LEV A, CN792: LEV B, CN793: LEV C
CN794: LEV D (**MXZ-4C/5C**),
CN795: LEV E (**MXZ-5C**),

Is there normal resistance to LEV coil?
(Refer to 12-5.)

Yes

Replace the outdoor control P.C. board.

No

Replace LEV coil.

CN791	Outdoor control P.C. board
CN792	
CN793	
CN794	
CN795	
CN797	

- When heating, room does not get warm.
- When cooling, room does not get cool.

Ⓔ How to check inverter/compressor

Disconnect the terminal of the compressor or the connector (CNMC) between the compressor and the outdoor power P.C. board. 3 minutes after the power supply is turned ON, start EMERGENCY OPERATION.

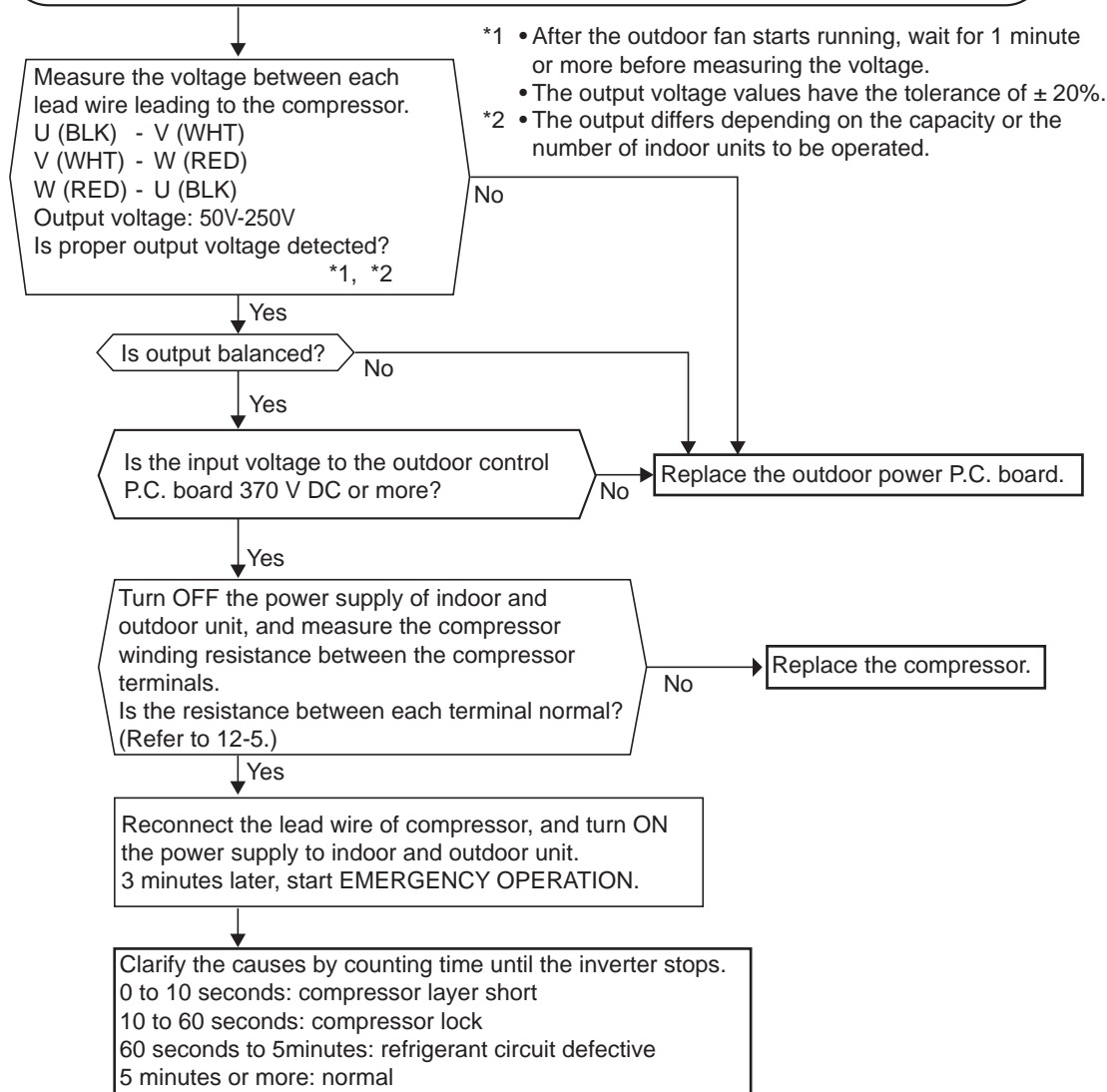

• When thermistor is abnormal,

⑤ Check of outdoor thermistors

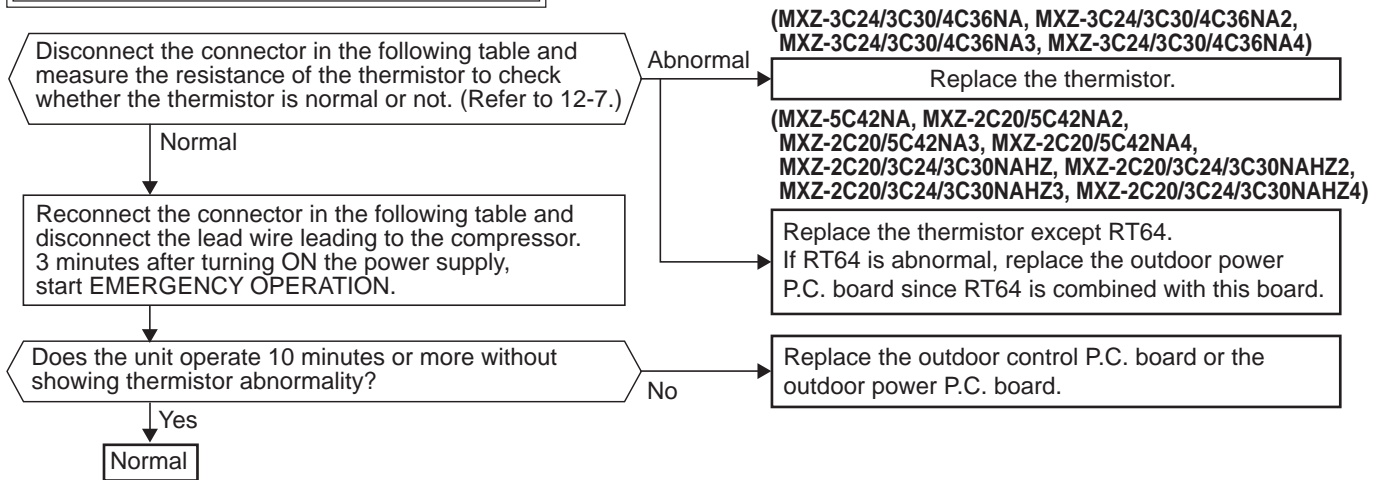

Thermistor	Symbol	Connector, Pin No.	Board
Defrost	RT61	Between CNTH1 pin1 and pin2	Outdoor control P.C. board
Discharge temperature	RT62	Between CNTH1 pin3 and pin4	
Outdoor heat exchanger temperature	RT68	Between CNTH1 pin7 and pin8	
Ambient temperature	RT65	Between CNTH2 pin1 and pin2	Outdoor power P.C. board
Fin temperature	RT64	Between CN171 pin1 and pin2	

• Fan motor does not operate or stops operating shortly after starting the operation.

© Check of outdoor fan motor

Disconnect CNF1 and measure the resistance of the outdoor fan motor.

CNF1	Outdoor control P.C. board
------	----------------------------

Model name of fan motor*:
SIC-71XX-XXXX-X, SIC-81XX-XXXX-X

Measuring points	Resistance
pin1 - pin4	∞
pin5 - pin4	60 k Ω
pin6 - pin4	160 k Ω
pin7 - pin4	∞

Model name of fan motor*:
SIC-82XX-XXXX-X, SIC-88XX-XXXX-X

Measuring points	Resistance
pin1 - pin4	1.1 M Ω
pin5 - pin4	40 k Ω
pin6 - pin4	220 k Ω
pin7 - pin4	∞

* To measure the resistance, connect the negative (-) end of the multimeter to pin4.

* See the spec name plate indicated in the diagram for the model name of fan motor.

* Where "X" in model name of fan motor represents numbers and letters

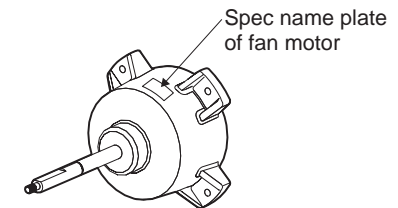

Is the resistance of outdoor fan motor normal? (Refer to right table)
No → Replace the outdoor fan motor.

Does the outdoor fan motor rotate smoothly?
No → Replace the outdoor fan motor.

Turn on the power supply to start operation and measure the voltage of connector CNF1.

CNF1	Voltage
pin1 - pin4	294/325 V DC
pin5 - pin4	15 V DC
pin6 - pin4	1 - 5 V DC

* To measure the voltage, connect the negative (-) end of the multimeter to pin4.

* Voltage between pin4 and 6 should be measured within 1 minute after the operation starts.

Is the voltage of connector CNF1 normal? (Refer to right table.)
No → Replace the outdoor control P.C. board.

Turn OFF the power supply and connect the connector CNF1.

Turn ON the power supply and measure the voltage of connector CNF1 while rotating the motor by the hand.

Does the voltage between pin7 and pin4 of connector CNF1 repeat 0V and 5V?
No → Replace the outdoor fan motor.

Start operation.

Does the fan motor operate for about 5 seconds?
No → Replace the outdoor fan motor.

Replace the outdoor control P.C. board.

• When the operation frequency does not go up from the lowest frequency.

⑧ Check of HPS

CN63H	Outdoor control P.C. board
-------	----------------------------

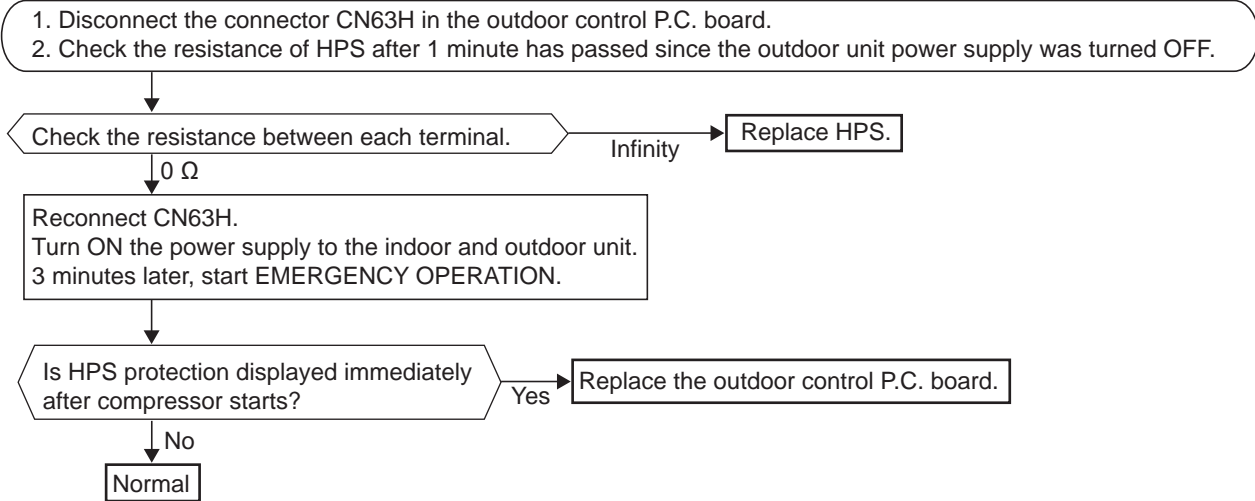

⑨ The other cases

Indoor unit does not operate. (different operating models in multi system)

- When you try to run 2 indoor units simultaneously, one for cooling and the other for heating, the unit which transmits signal to the outdoor units first decides the operation mode.
- When the above situation occurs, set all the indoor units to the same mode, turn OFF the indoor units, and then turn them back ON.
- Though the top of the indoor unit sometimes gets warm, this does not mean malfunction. The reason is that the refrigerant gas continuously flows into the indoor unit even while it is not operating.

⑩ Check of bus-bar voltage

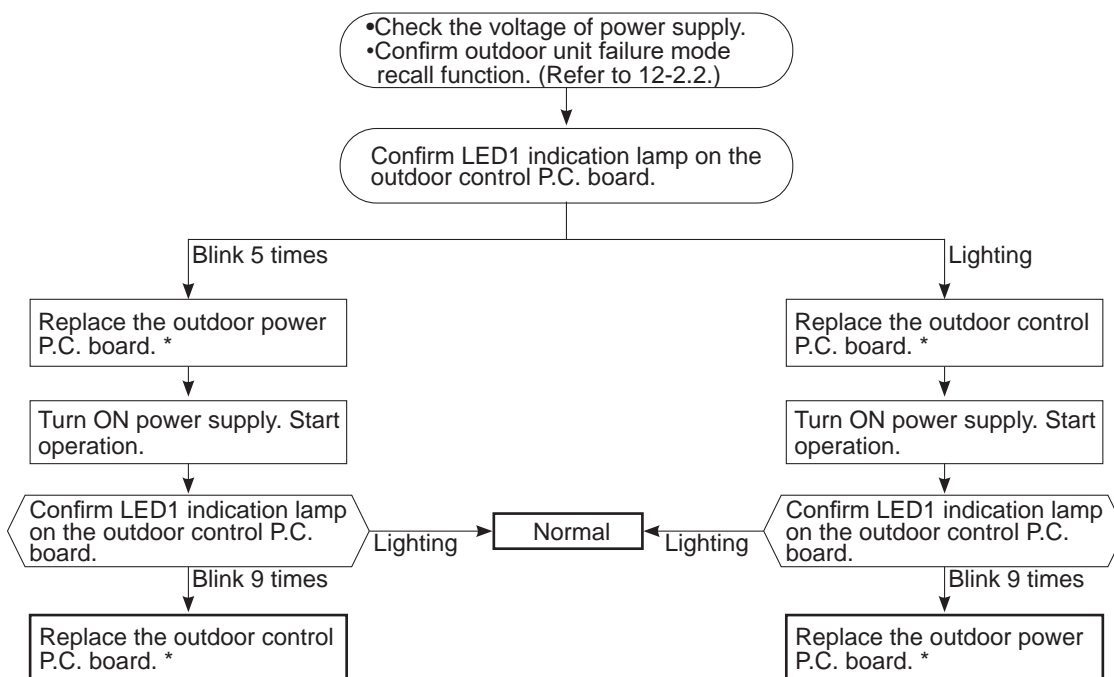

* Turn OFF power supply before removing P.C. board.

12-7. TEST POINT DIAGRAM AND VOLTAGE

1. Outdoor control P.C. board

MXZ-2C20NA2

MXZ-2C20NA3

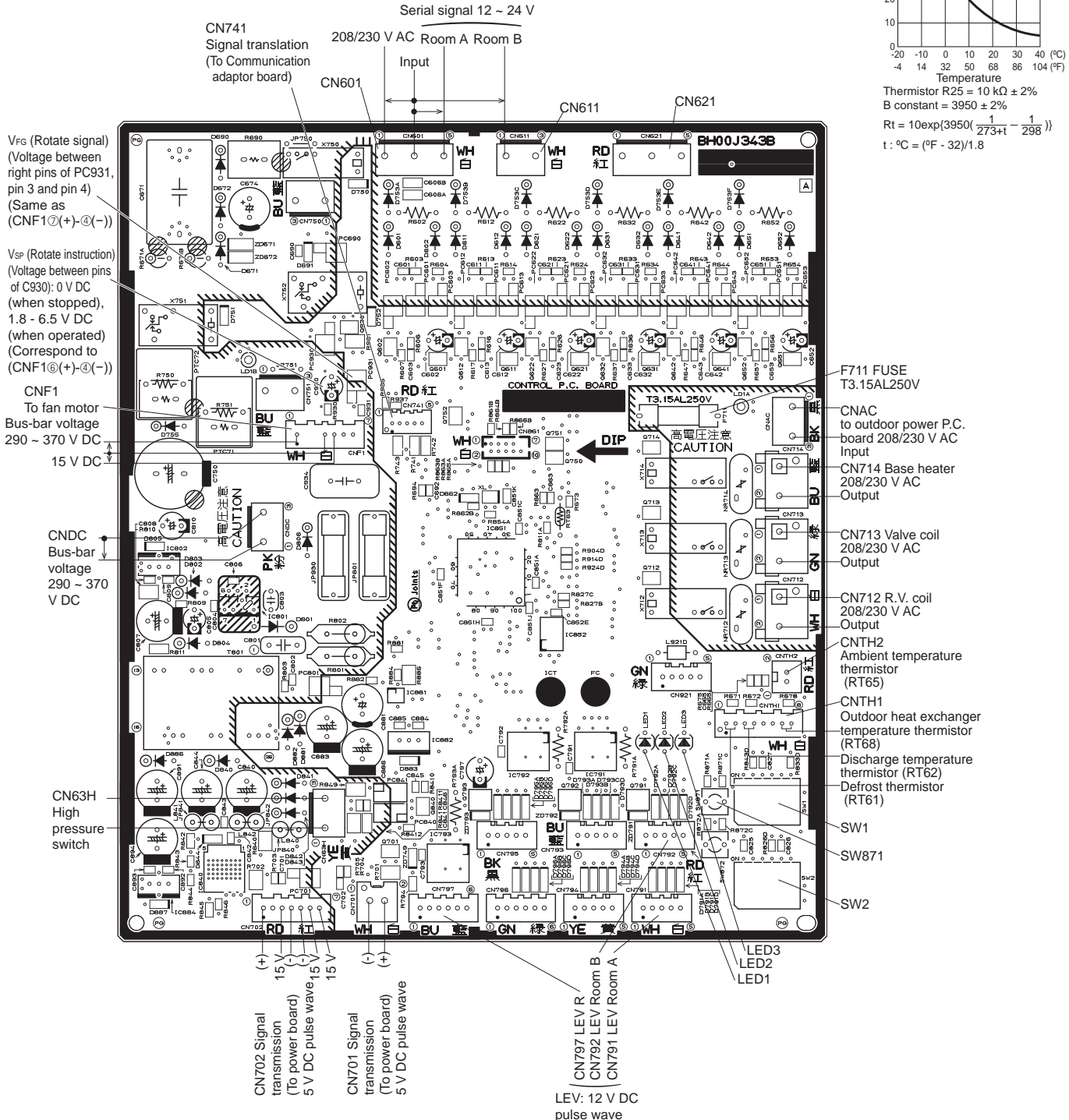
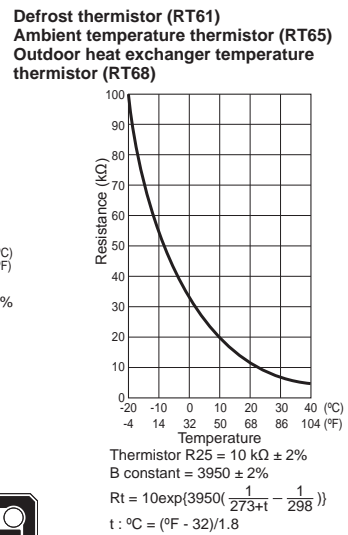
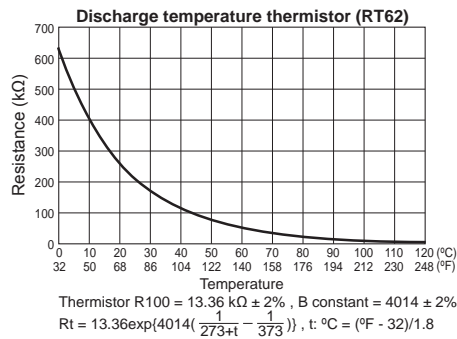

1. Outdoor control P.C. board MXZ-2C20NA4

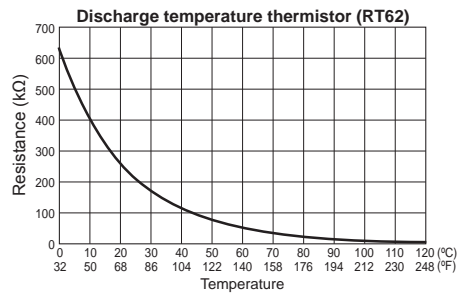

Thermistor R100 = 13.36 kΩ ± 2%, B constant = 4014 ± 2%

$$R_t = 13.36 \exp\left(4014 \left(\frac{1}{273+t} - \frac{1}{373}\right)\right); t: ^\circ\text{C} = (^{\circ}\text{F} - 32)/1.8$$

Defrost thermistor (RT61)
Ambient temperature thermistor (RT65)
Outdoor heat exchanger temperature thermistor (RT68)

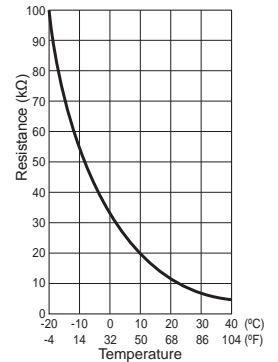

Serial signal 12 ~ 24 V

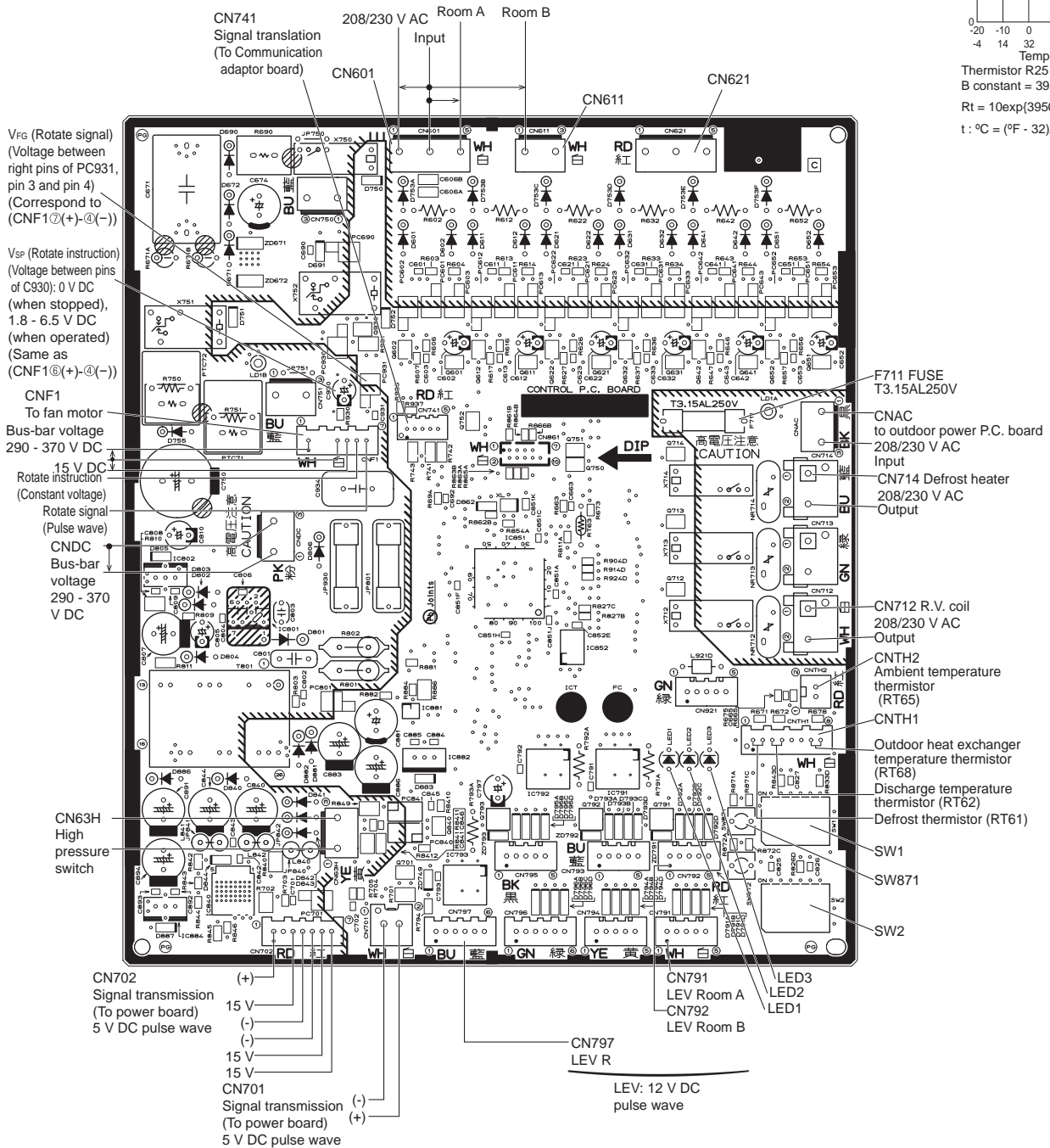

1. Outdoor control P.C. board
MXZ-3C24NA **MXZ-3C30NA**
MXZ-4C36NA

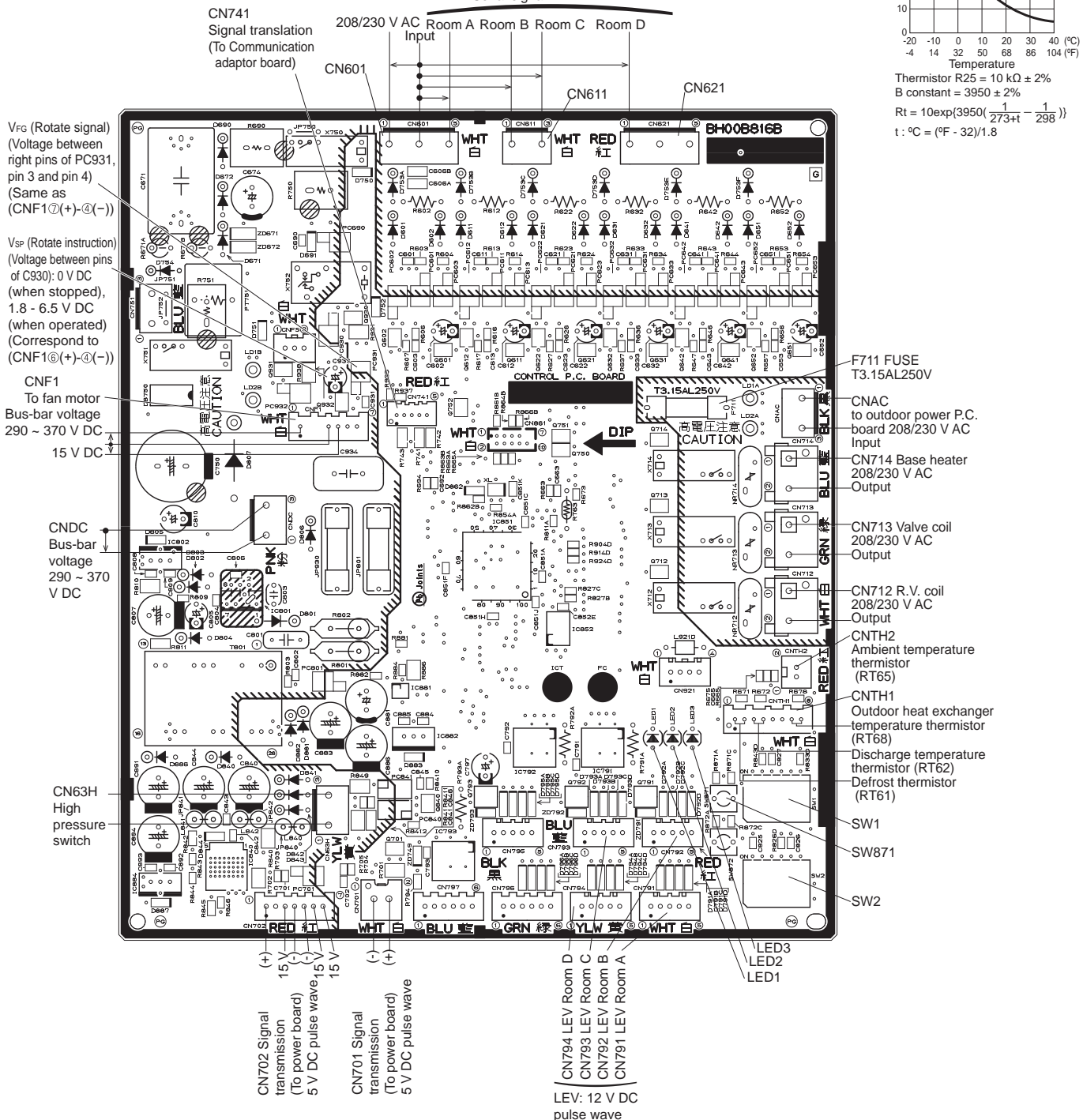
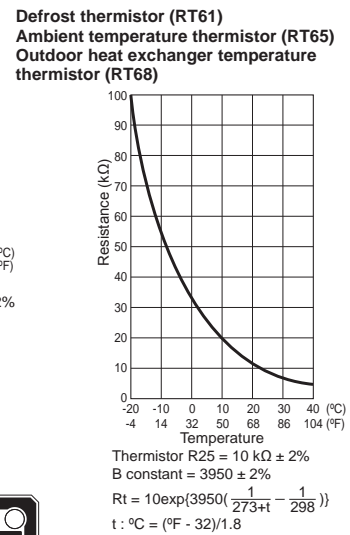
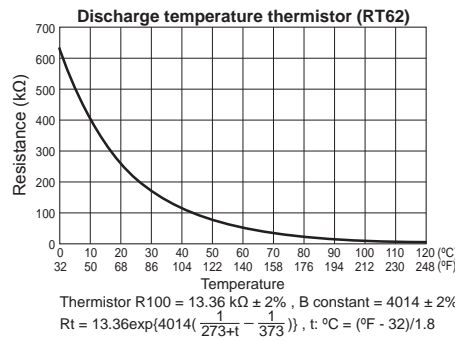

1. Outdoor control P.C. board

- MXZ-3C24NA2 MXZ-3C30NA2
- MXZ-4C36NA2
- MXZ-3C24NA3 MXZ-3C30NA3
- MXZ-4C36NA3

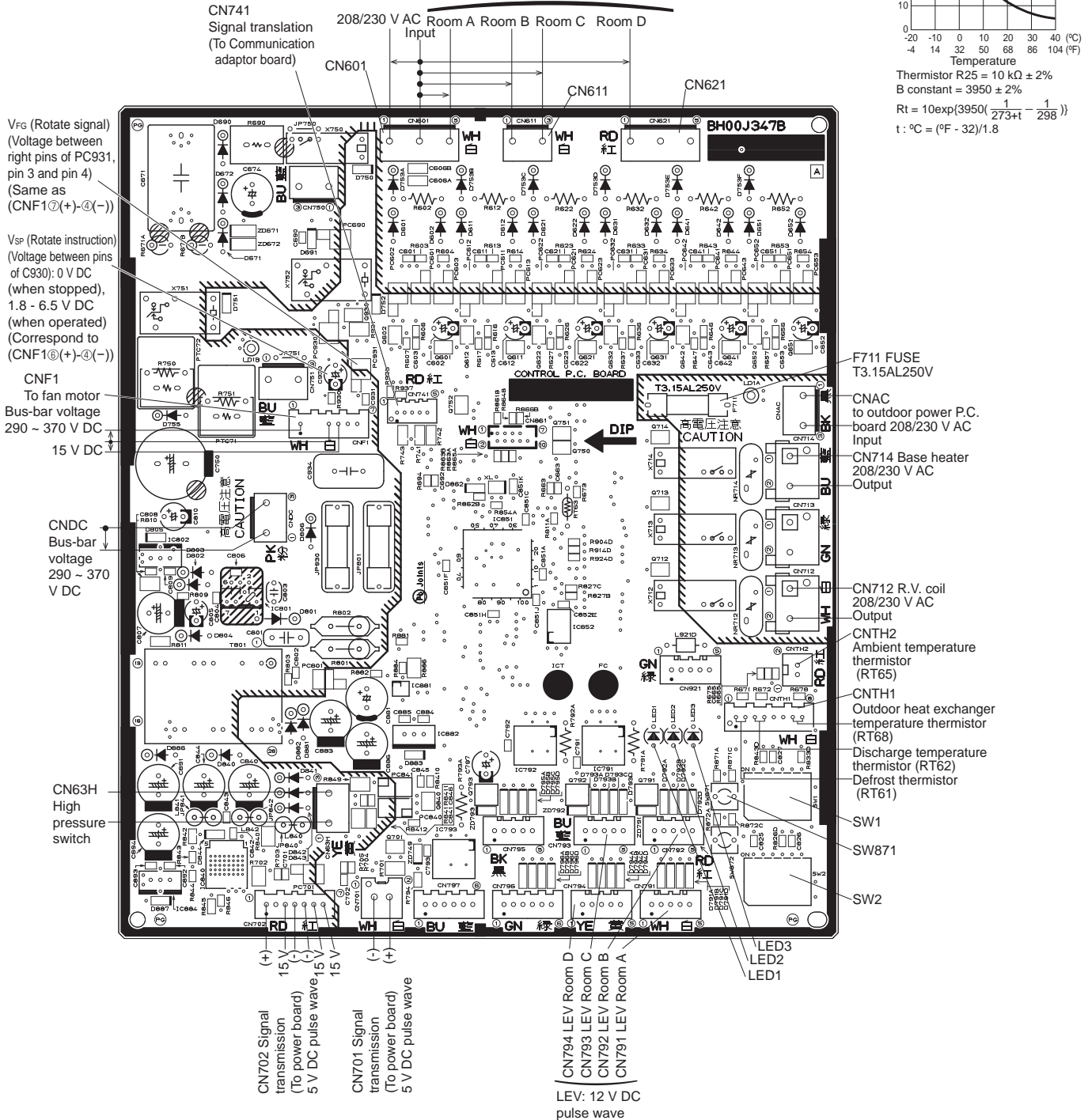
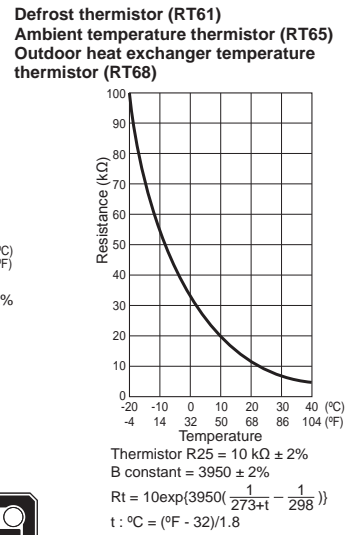
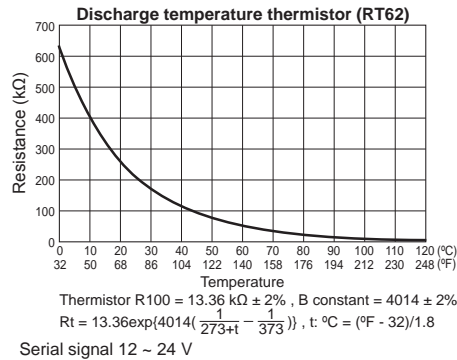

1. Outdoor control P.C. board
MXZ-3C24NA4 MXZ-3C30NA4
MXZ-4C36NA4

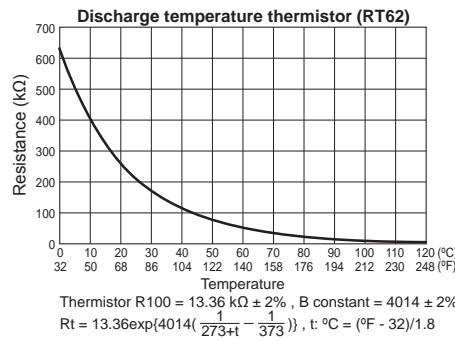

Defrost thermistor (RT61)
 Ambient temperature thermistor (RT65)
 Outdoor heat exchanger temperature thermistor (RT68)

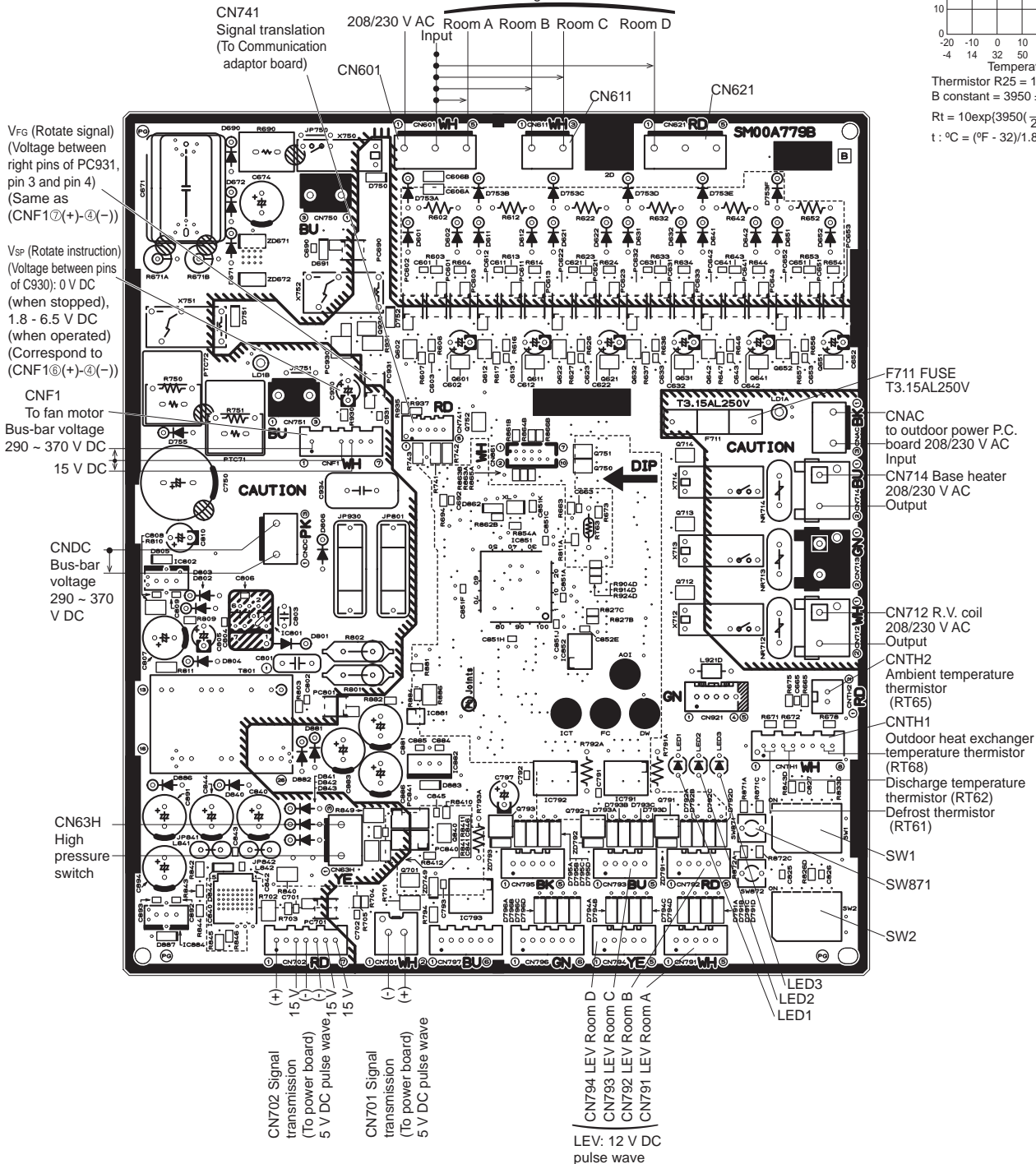
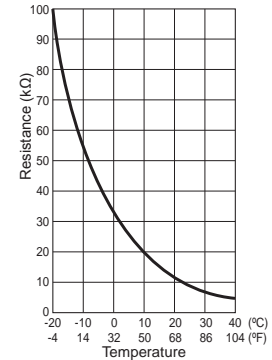

1. Outdoor control P.C. board

MXZ-5C42NA

MXZ-2C20NAHZ MXZ-3C24NAHZ

MXZ-3C30NAHZ

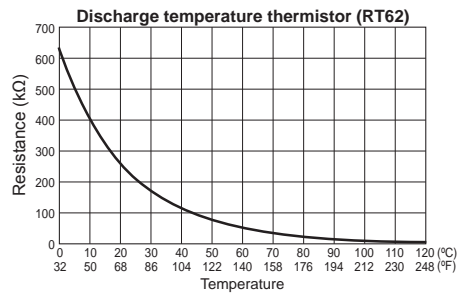

Thermistor R100 = 13.36 kΩ ± 2%, B constant = 4014 ± 2%
 $R_t = 13.36 \exp(4014(\frac{1}{273+t} - \frac{1}{373}))$; t: °C = (°F - 32)/1.8

Serial signal 12 ~ 24 V

Defrost thermistor (RT61)
 Ambient temperature thermistor (RT65)
 Outdoor heat exchanger temperature thermistor (RT68)

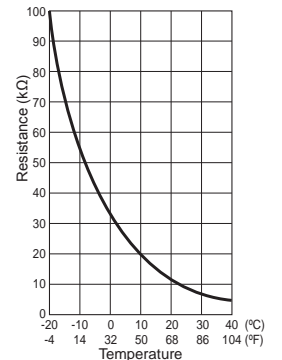

Thermistor R25 = 10 kΩ ± 2%
 B constant = 3950 ± 2%
 $R_t = 10 \exp(3950(\frac{1}{273+t} - \frac{1}{298}))$
 t: °C = (°F - 32)/1.8

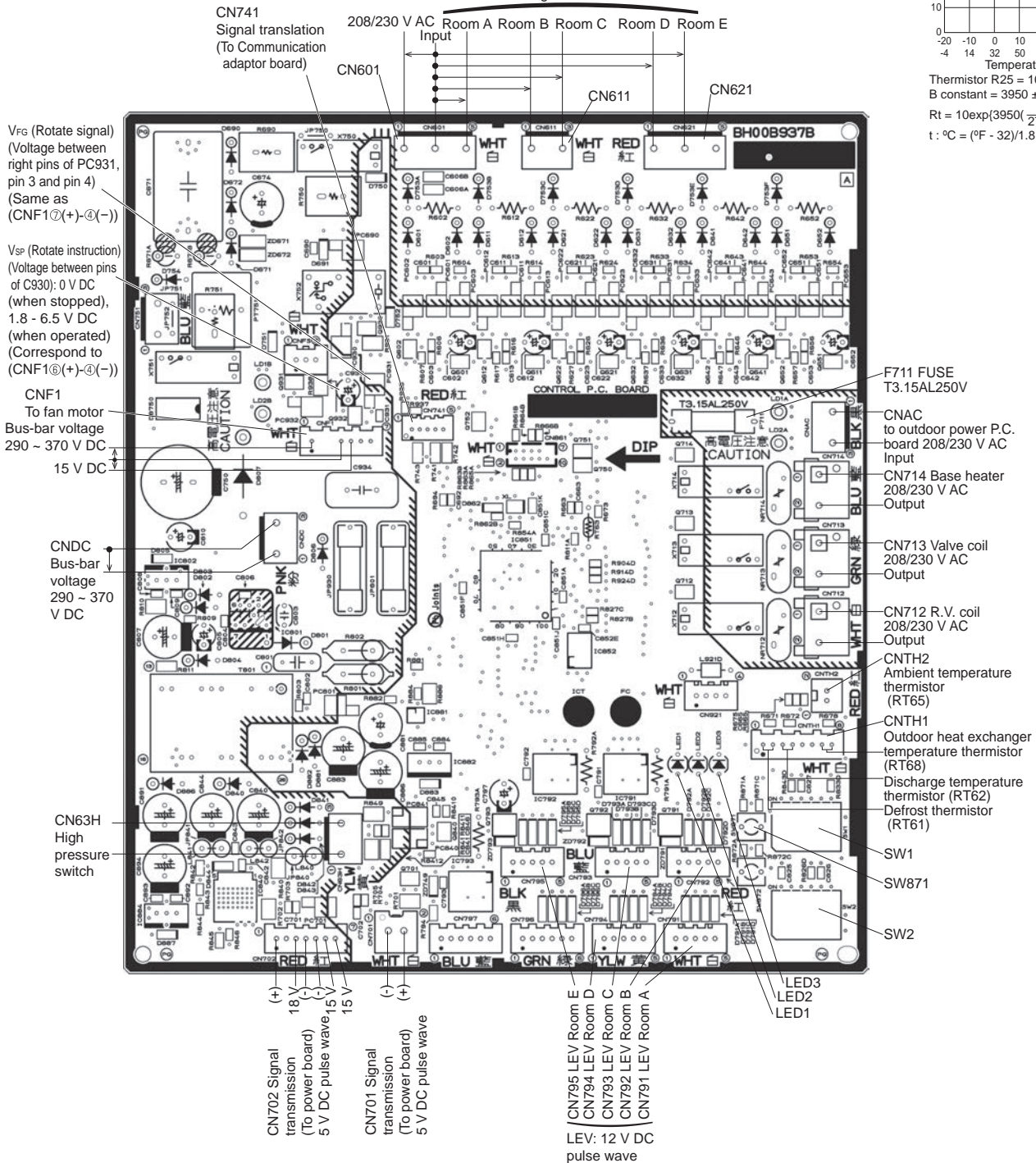

1. Outdoor control P.C. board

MXZ-5C42NA2

MXZ-5C42NA3

MXZ-2C20NAHZ2 MXZ-3C24NAHZ2

MXZ-3C30NAHZ2

MXZ-2C20NAHZ3 MXZ-3C24NAHZ3

MXZ-3C30NAHZ3

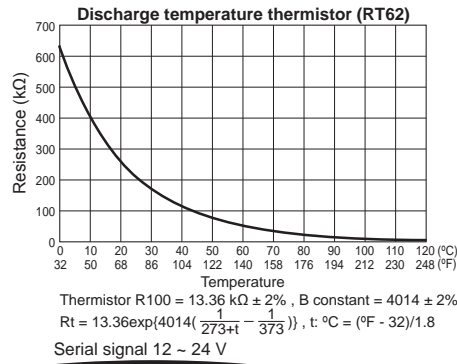

Defrost thermistor (RT61)
Ambient temperature thermistor (RT65)
Outdoor heat exchanger temperature thermistor (RT68)

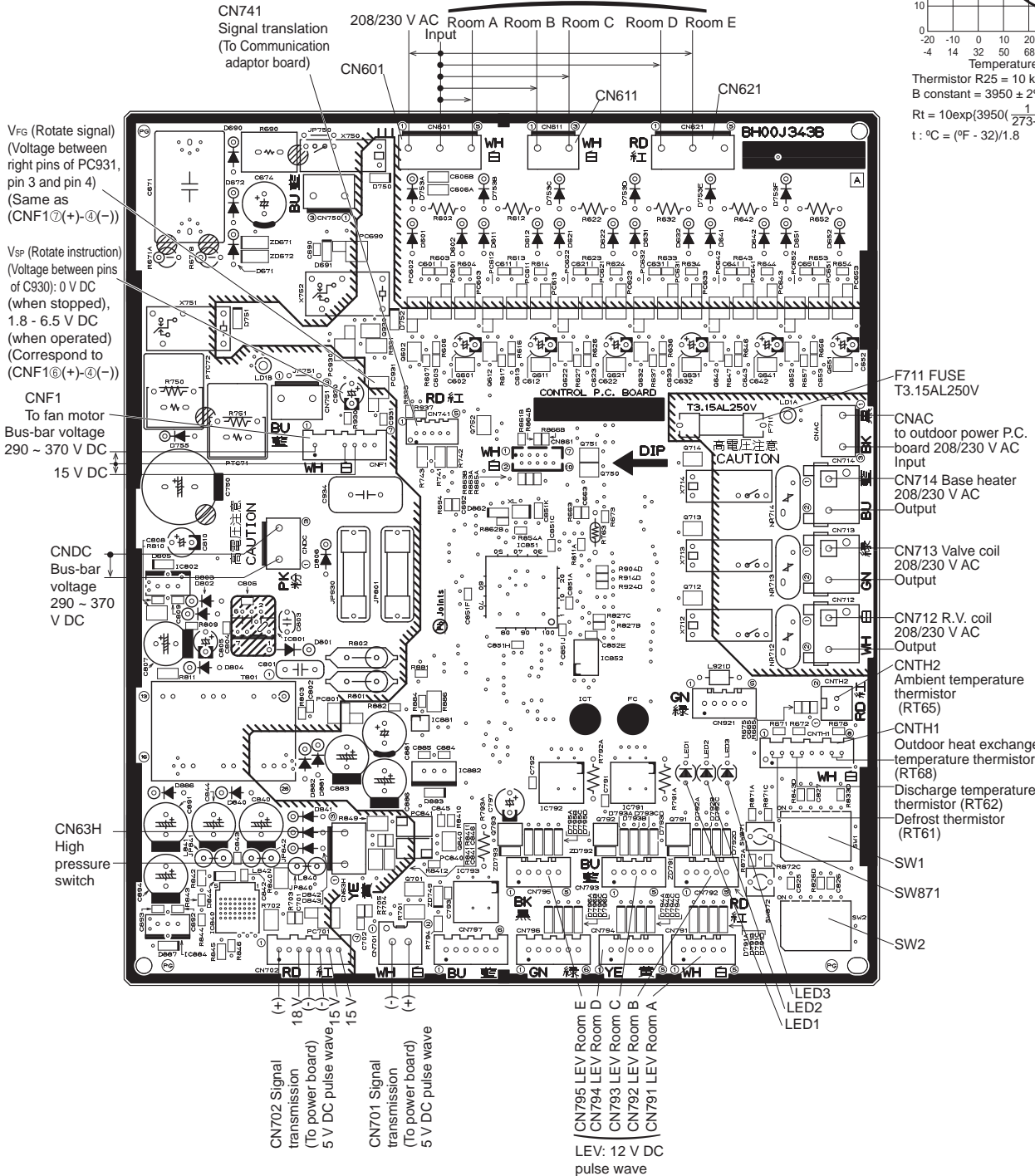
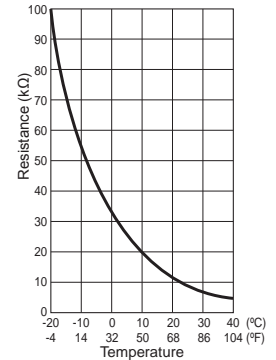

1. Outdoor control P.C. board

MXZ-5C42NA4

MXZ-2C20NAHZ4 MXZ-3C24NAHZ4

MXZ-3C30NAHZ4

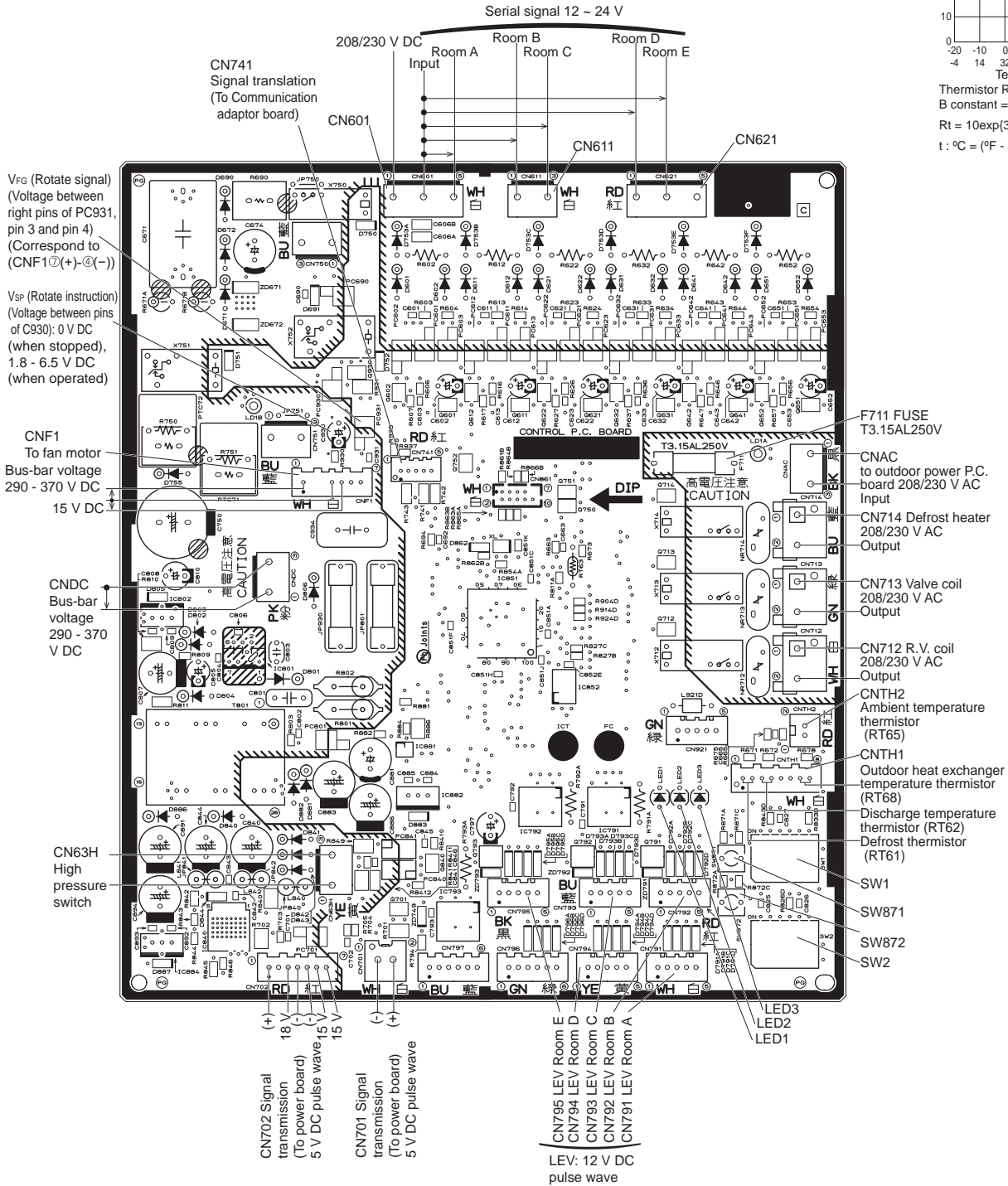
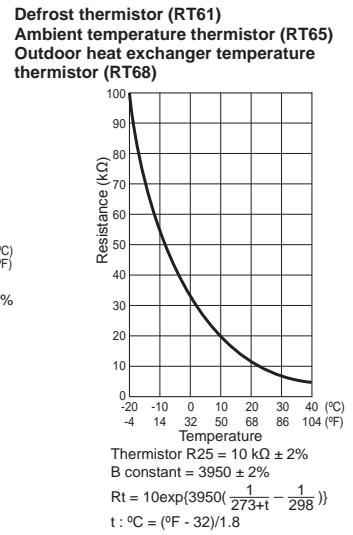
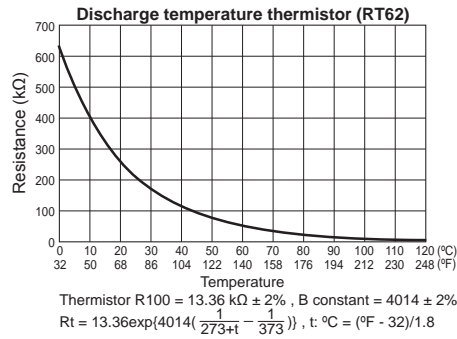

2. Outdoor power P.C. board

MXZ-2C20NA2 MXZ-2C20NA3 MXZ-2C20NA4

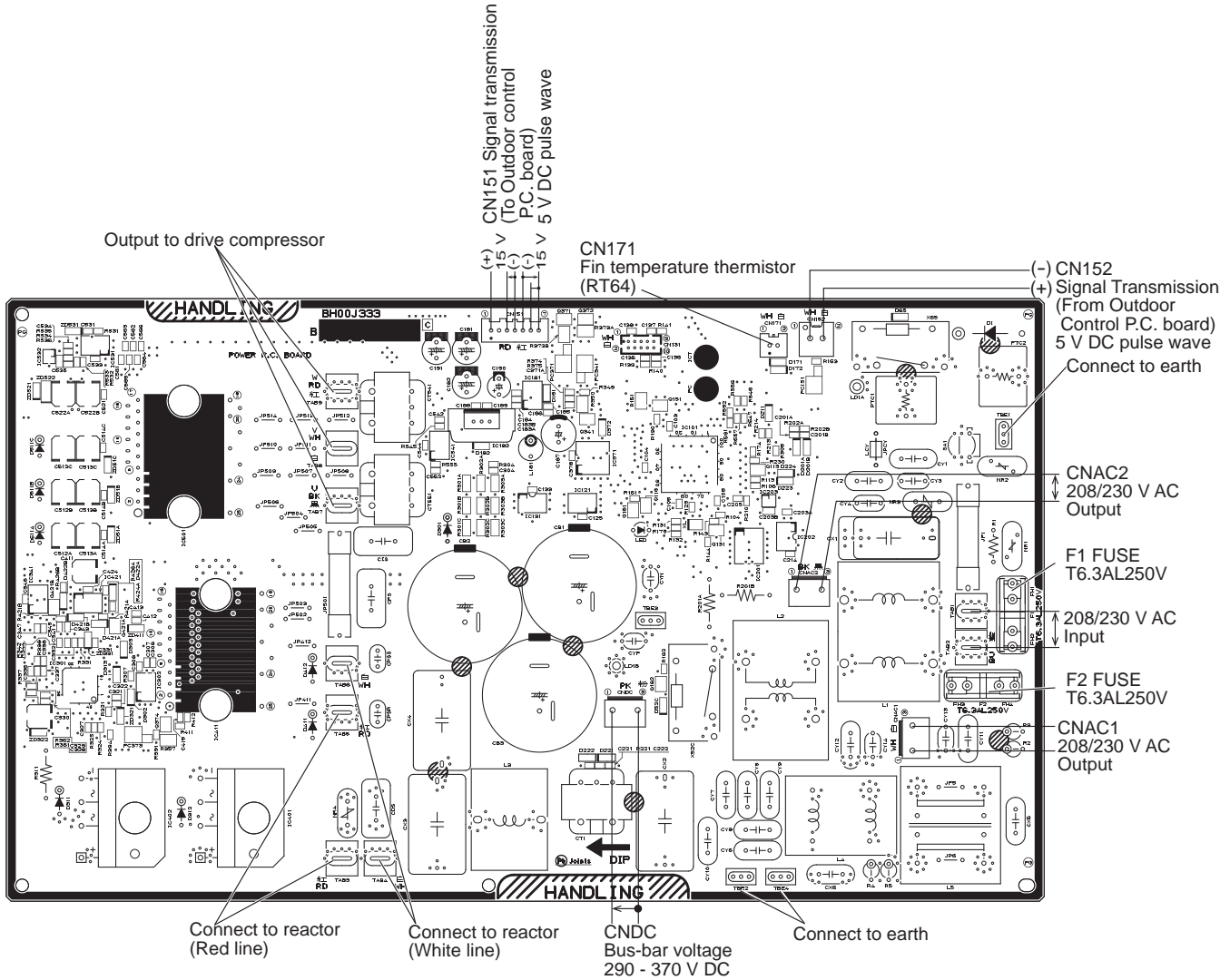

Fin temperature thermistor (RT64)

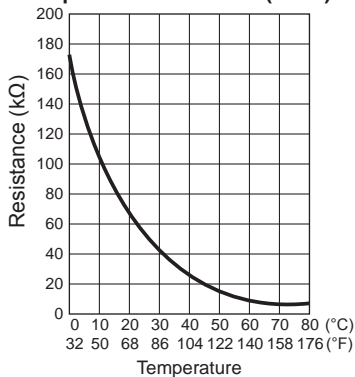

Thermistor R50 = 17 kΩ ± 2%

B constant = 4150 ± 3%

$$R_t = 17 \exp\left\{4150 \left(\frac{1}{273+t} - \frac{1}{323}\right)\right\}$$

$$t : ^\circ\text{C} = (^\circ\text{F} - 32)/1.8$$

2. Outdoor power P.C. board

MXZ-3C24NA MXZ-3C24NA2 MXZ-3C24NA3
 MXZ-3C30NA MXZ-3C30NA2 MXZ-3C30NA3
 MXZ-4C36NA MXZ-4C36NA2 MXZ-4C36NA3

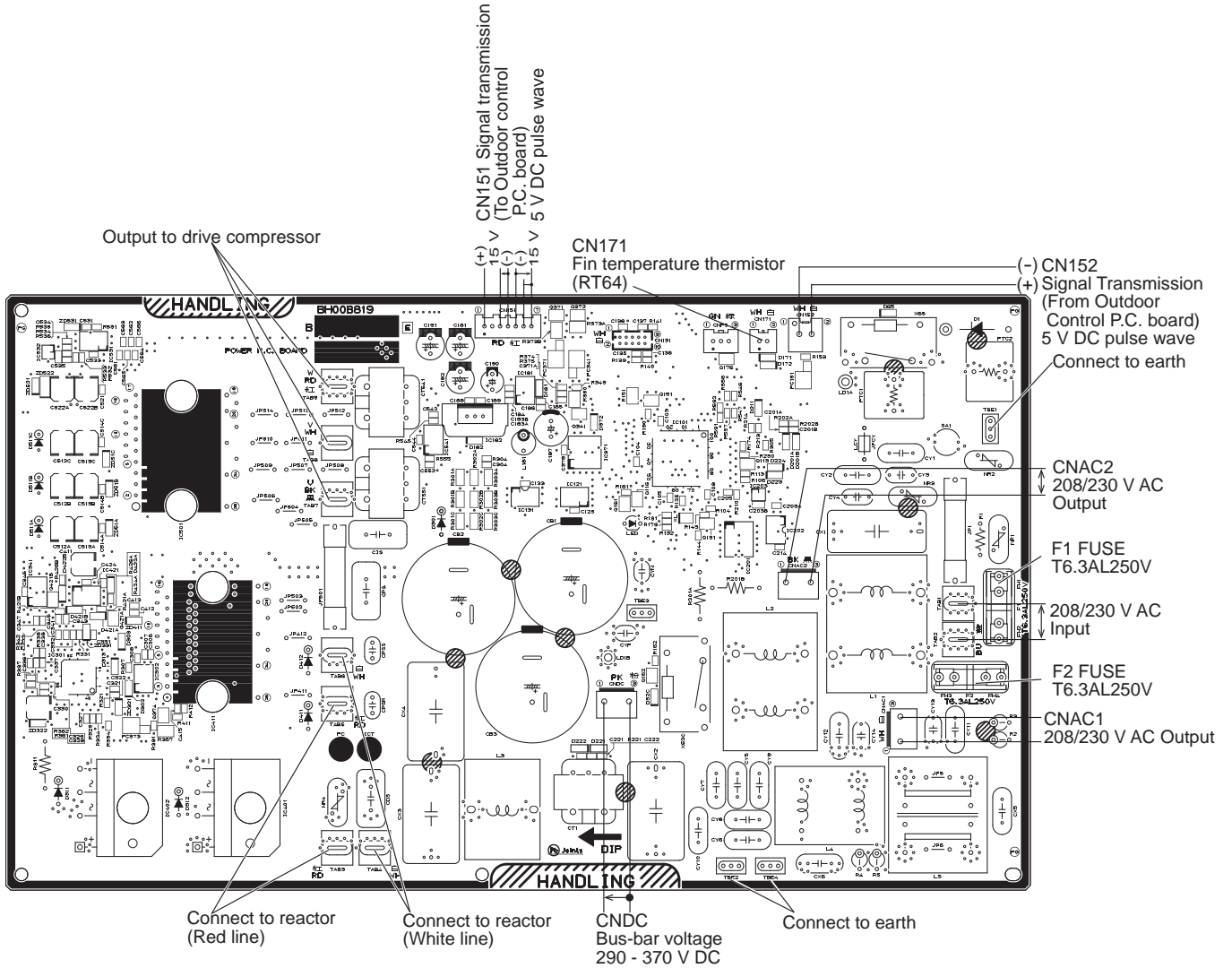

Fin temperature thermistor (RT64)

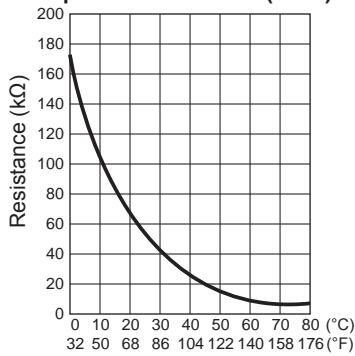

Thermistor R50 = 17 kΩ ± 2%

B constant = 4150 ± 3%

$$R_t = 17 \exp\left\{4150 \left(\frac{1}{273+t} - \frac{1}{323} \right)\right\}$$

$$t: ^\circ\text{C} = (^\circ\text{F} - 32)/1.8$$

2. Outdoor power P.C. board

MXZ-3C24NA4 MXZ-3C30NA4 MXZ-4C36NA4

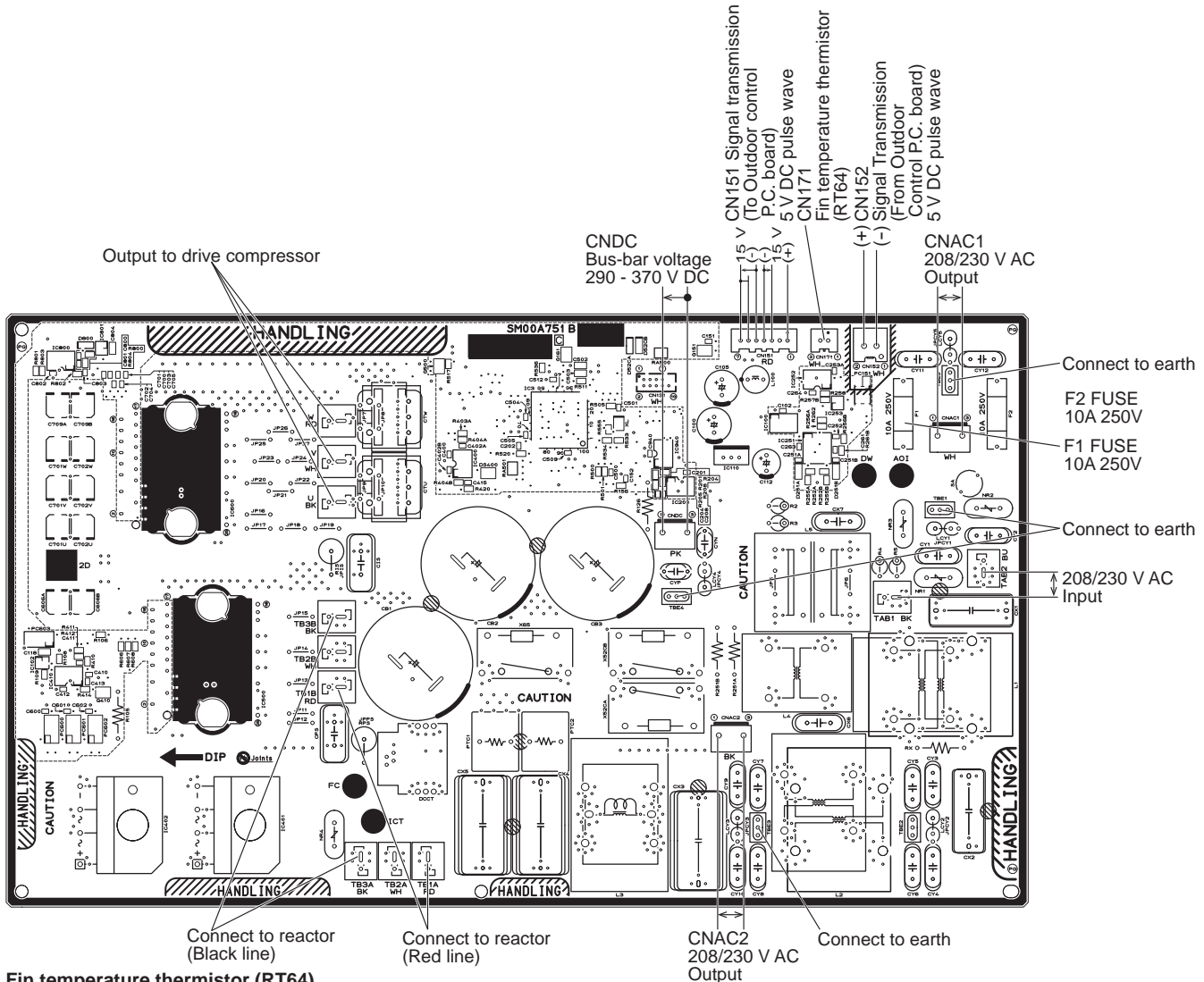

Fin temperature thermistor (RT64)

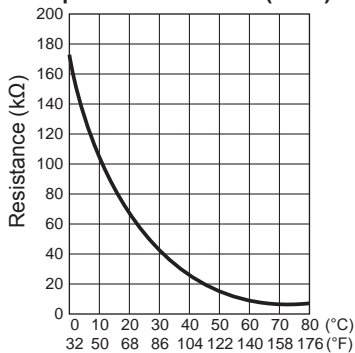

Thermistor R₅₀ = 17 kΩ ± 2%

B constant = 4150 ± 3%

$$R_t = 17 \exp\left\{4150 \left(\frac{1}{273+t} - \frac{1}{323}\right)\right\}$$

$$t : ^\circ\text{C} = (^\circ\text{F} - 32)/1.8$$

2. Outdoor power P.C. board

MXZ-5C42NA MXZ-5C42NA2 MXZ-5C42NA3
MXZ-2C20NAHZ MXZ-2C20NAHZ2 MXZ-2C20NAHZ3
MXZ-3C24NAHZ MXZ-3C24NAHZ2 MXZ-3C24NAHZ3
MXZ-3C30NAHZ MXZ-3C30NAHZ2 MXZ-3C30NAHZ3

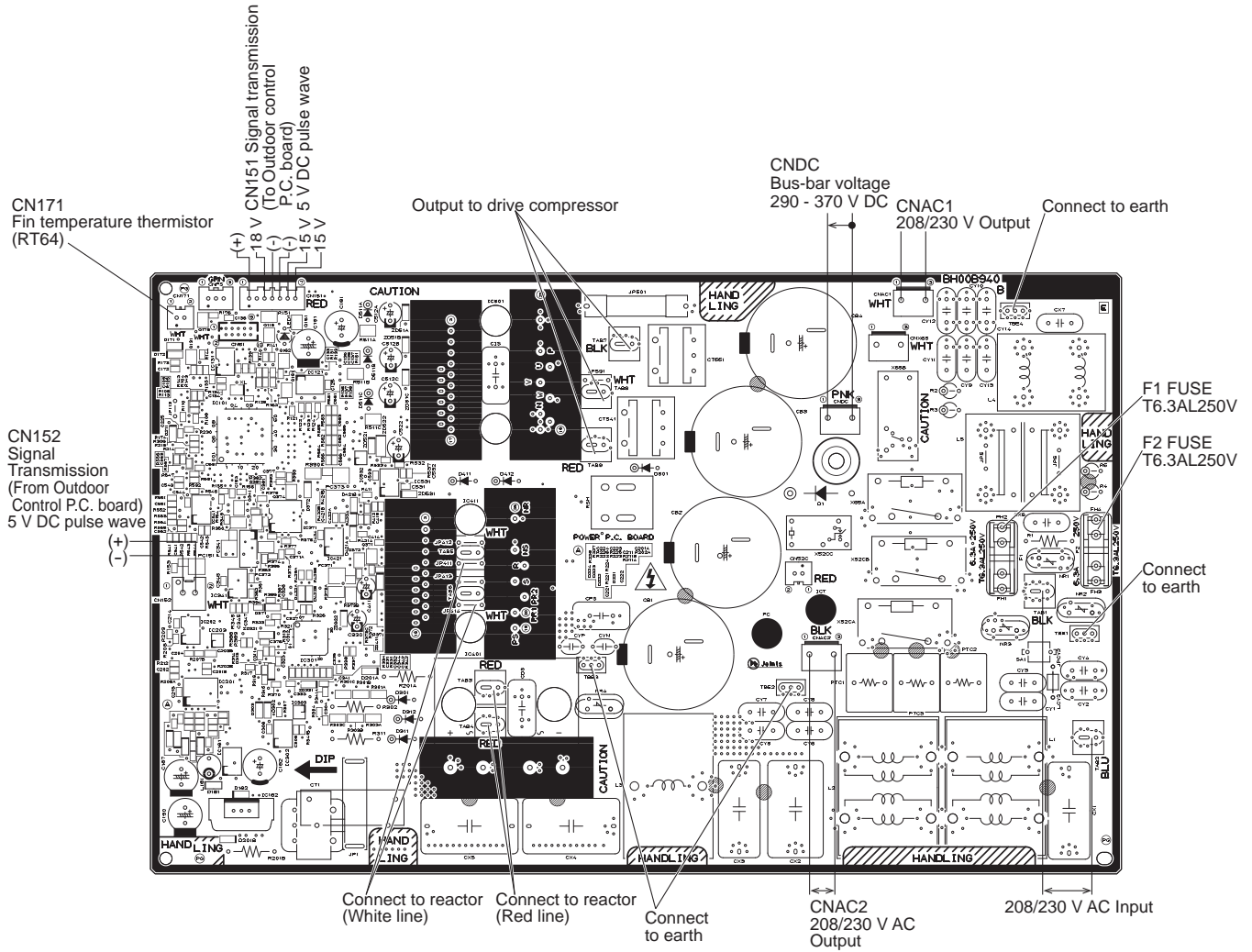

Fin temperature thermistor (RT64)

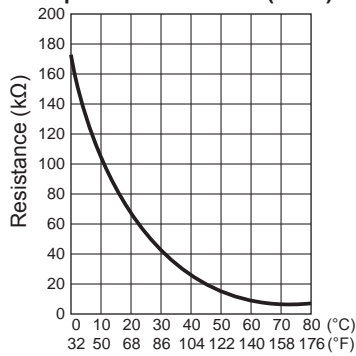

Thermistor R50 = 17 kΩ ± 2%

B constant = 4150 ± 3%

$$R_t = 17 \exp\left\{4150 \left(\frac{1}{273+t} - \frac{1}{323} \right)\right\}$$

$$t: ^\circ\text{C} = (^\circ\text{F} - 32)/1.8$$

2. Outdoor power P.C. board

MXZ-5C42NA4

MXZ-2C20NAHZ4

MXZ-3C24NAHZ4

MXZ-3C30NAHZ4

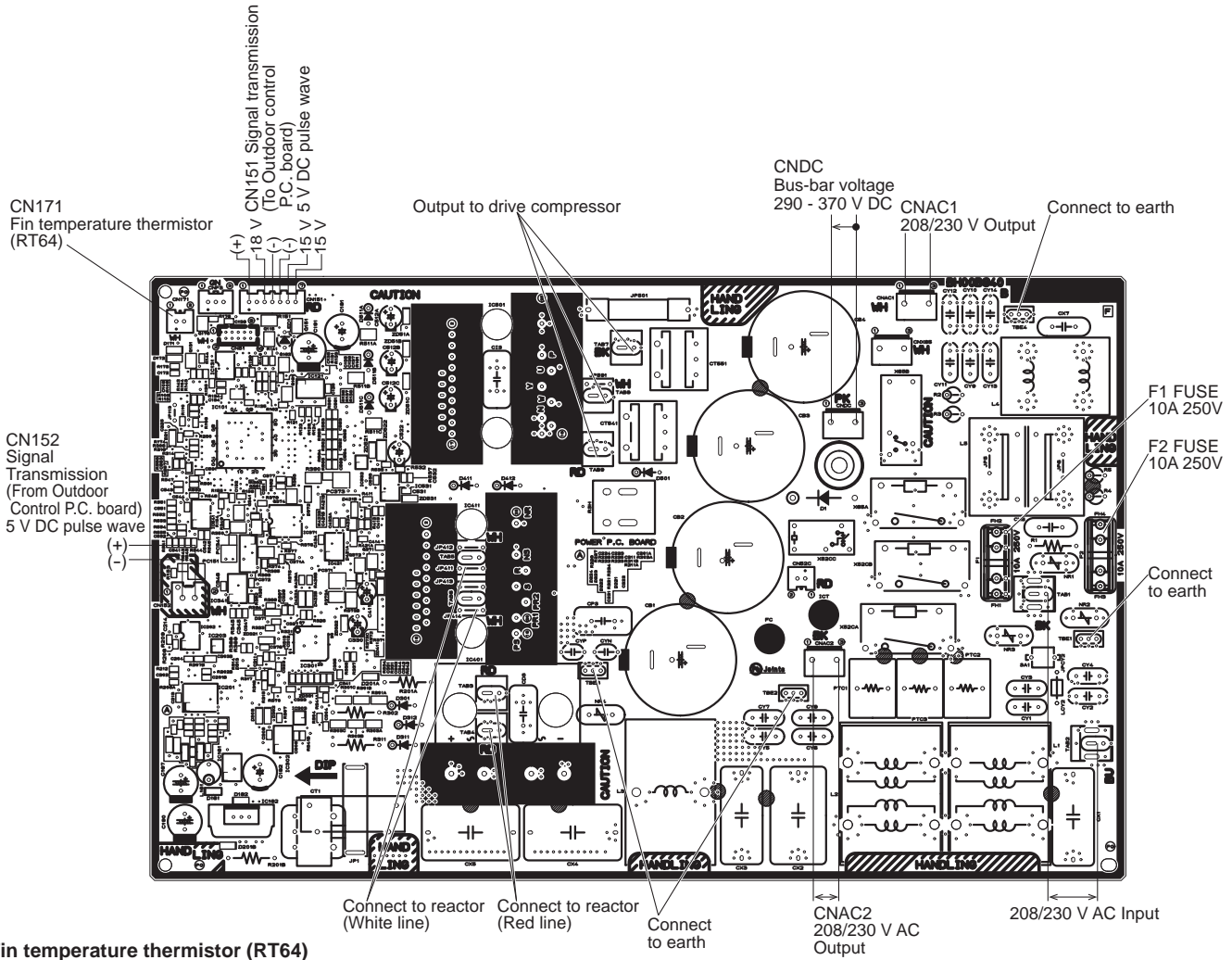

Fin temperature thermistor (RT64)

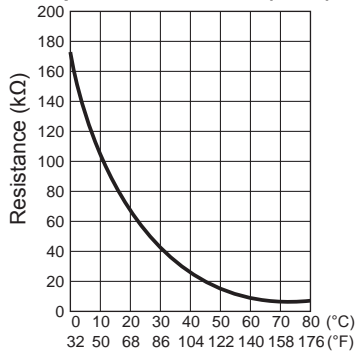

Thermistor R50 = 17 kΩ ± 2%
 B constant = 4150 ± 3%

$$R_t = 17 \exp\left\{4150 \left(\frac{1}{273+t} - \frac{1}{323}\right)\right\}$$

$$t: ^\circ\text{C} = (^\circ\text{F} - 32)/1.8$$

<Detaching method of the terminal with locking mechanism>

The terminal which has the locking mechanism can be detached as shown below.

There are 2 types of the terminal with locking mechanism.

The terminal without locking mechanism can be detached by pulling it out.

Check the shape of the terminal before detaching.

(1) Slide the sleeve and check if there is a locking lever or not.

(2) The terminal with this connector shown below has the locking mechanism.

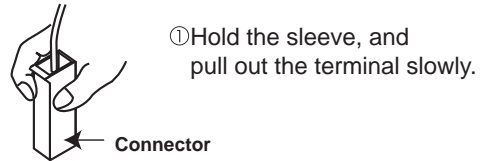
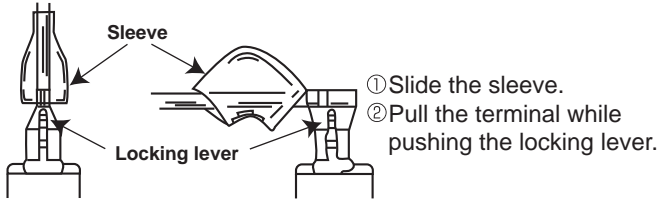

13-1. MXZ-2C20NA2 MXZ-2C20NA3 MXZ-2C20NA4

NOTE: Turn OFF the power supply before disassembly.

————>: Indicates the visible parts in the photos/figures.
 - - - ->: Indicates the invisible parts in the photos/figures.

OPERATING PROCEDURE	PHOTOS/FIGURES
<p>1. Removing the cabinet and the panels</p> <p>(1) Remove all the screws of the service panel, and remove the service panel.</p> <p>(2) Disconnect the power supply cord and indoor/outdoor connecting wires.</p> <p>(3) Remove all the screws of the top panel, and remove the top panel.</p> <p>(4) Remove all the screws of the cabinet, and remove the cabinet.</p> <p>(5) Remove all the screws of the back panel, and remove the back panel (Photo 3).</p>	<p>Photo 1</p> <p>Screws of the top panel</p> <p>Screws of the cabinet</p> <p>Screws of service panel</p> <p>Photo 2</p> <p>Screws of the top panel</p> <p>Screws of the cabinet</p> <p>Screws of the sub panel</p> <p>Photo 3</p> <p>Screw of the rear guard</p> <p>Screws of the back panel</p> <p>Screws of the cabinet</p> <p>Screws of the back panel</p> <p>Screws of the back panel</p> <p>Screws of the back panel</p>

OPERATING PROCEDURE

2. Removing the outdoor control P.C. board, the outdoor power P.C. board and the reactor

- (1) Remove the service panel (Photo 1).
- (2) Disconnect the power supply cord and indoor/outdoor connecting wires.
- (3) Remove the top panel, the cabinet, and the back panel (Photo 1, 2, 3).
- (4) Disconnect all the connectors and the lead wires on the outdoor control P.C. board.
- (5) Disengage all the catches of the outdoor control P.C. board, and remove the outdoor control P.C. board.
- (6) Remove all the screws of the electrical box assembly, disengage all the catches of the electrical box assembly, and remove the electrical box assembly.
- (7) Remove all the screws of outdoor control P.C. board holder, and remove the outdoor control P.C. board holder.
- (8) Remove all the screws of the reactor, and remove the reactor.
- (9) Remove all the screws of the reactor bed, and remove the reactor bed.
- (10) Remove all the screws of the heat sink support, and remove the heat sink support.
- (11) Remove all the screws fixing the outdoor power P.C. board.
- (12) Disconnect the connectors and the lead wires on the outdoor power P.C. board.

PHOTOS/FIGURES

Photo 4

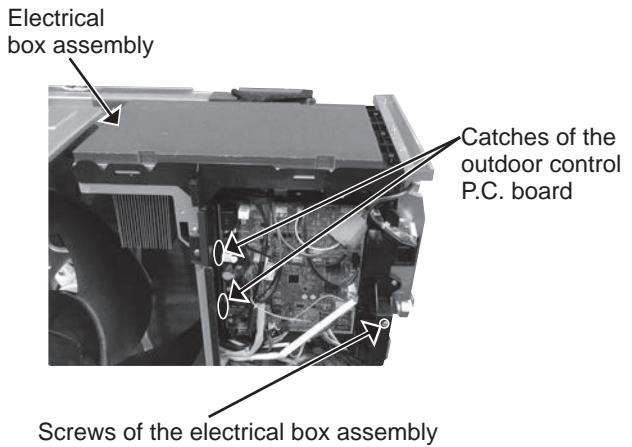

Photo 5

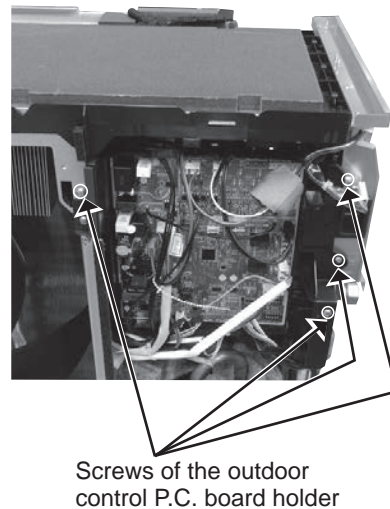

Photo 7

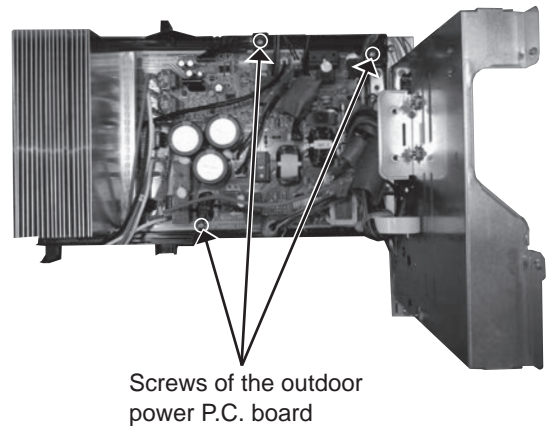
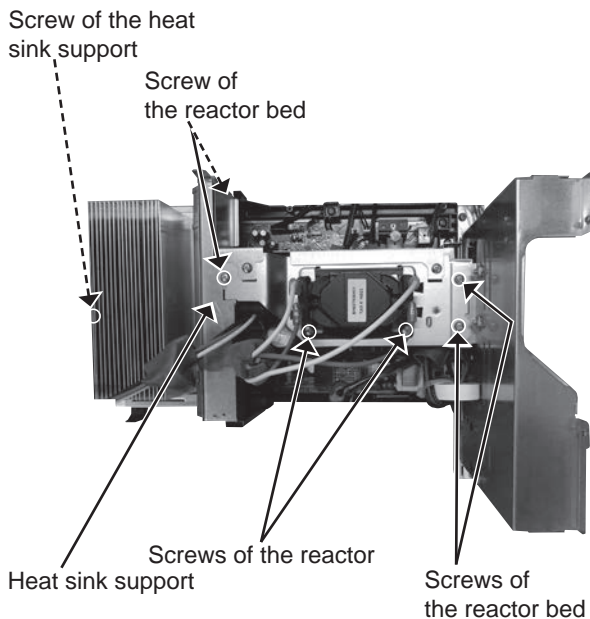

Photo 6



OPERATING PROCEDURE

3. Removing the fan motor

- (1) Remove the service panel (Photo 1).
- (2) Disconnect the power supply cord and indoor/outdoor connecting wires.
- (3) Remove the top panel, the cabinet, and the back panel (Photo 1, 2, 3).
- (4) Disconnect the connectors of CN712, CNF1, CNTH1, CNTH2, CN63H, CN791, CN792, CN797 on the outdoor control P.C. board and disconnect the relay connector of the compressor lead wire.
- (5) Remove all the screws of the electrical box assembly, and remove the electrical box assembly (Photo 4).
- (6) Remove the propeller fan.
- (7) Remove the fan motor.

NOTE: The propeller fan nut is a reverse thread.

PHOTOS/FIGURES

Photo 8

Screws of the outdoor fan motor

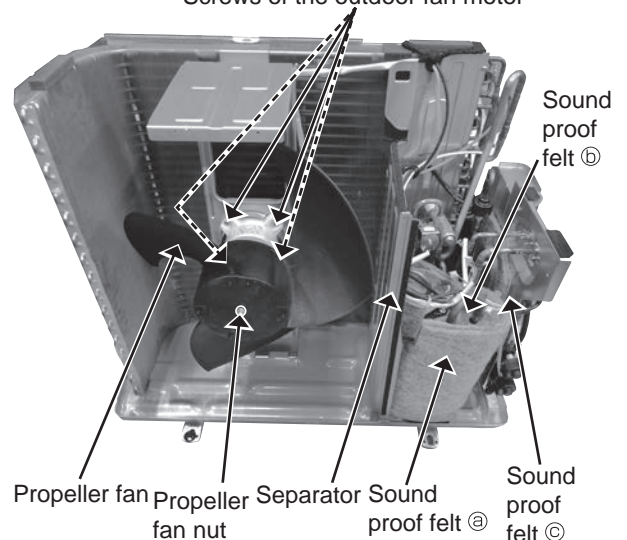

4. Removing the compressor and the 4-way valve

- (1) Remove the service panel (Photo 1).
- (2) Disconnect the power supply cord and indoor/outdoor connecting wires.
- (3) Remove the top panel, the cabinet, and the back panel (Photo 1, 2, 3).
- (4) Recover gas from the refrigerant circuit.

NOTE: Recover gas from the pipes until the pressure gauge shows 0 kg/cm² (0 MPa).

- (5) Disconnect the outdoor control P.C. board connectors: CNF1, CNTH1, CNTH2, CN63H, CN791, CN792, CN797, CN712.
- (6) Disconnect the compressor lead wire from the terminal of the compressor (U, V, W).
- (7) Remove all the screws of the electrical box assembly, and remove the electrical box assembly (Photo 4).
- (8) Remove the propeller fan.
- (9) Remove the sound proof felt (a), (b) and (c).
- (10) Remove all the screws of the separator, and remove the separator.
- (11) Detach all the brazed parts of the compressor suction and discharge pipes.
- (12) Remove all the compressor nuts and remove the compressor.
- (13) Detach all the brazed parts of the 4-way valve and pipe.

Photo 9

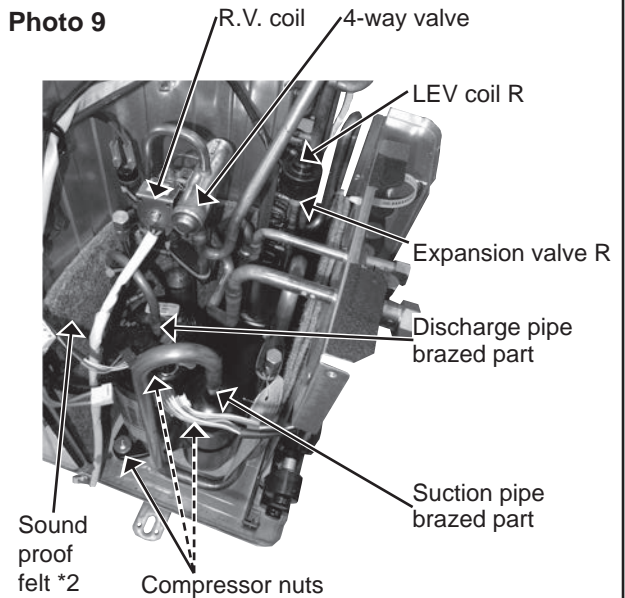
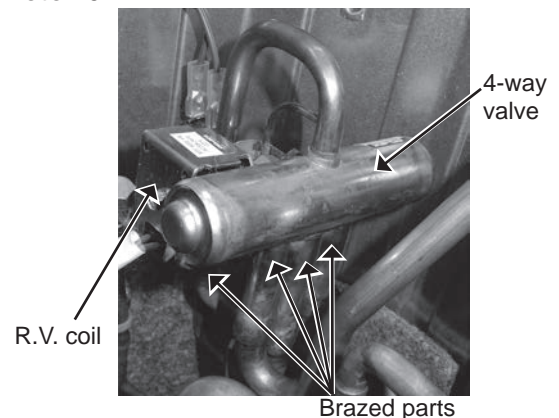
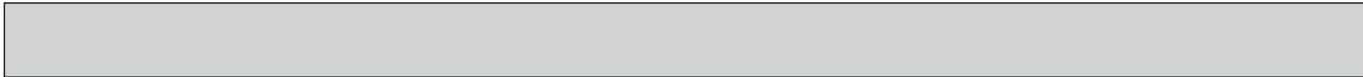
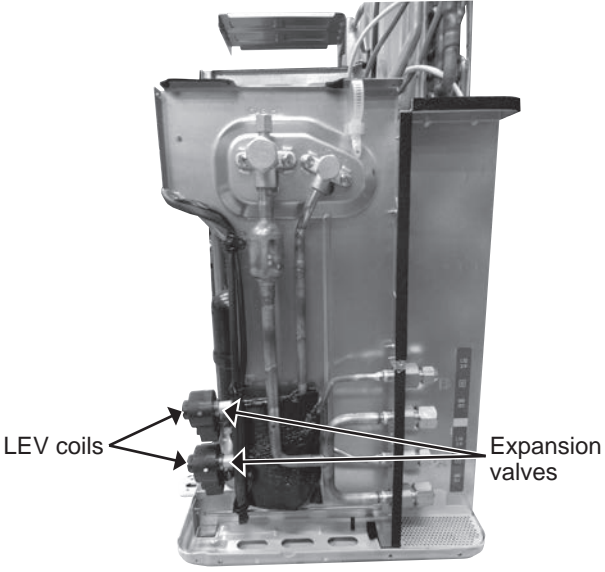
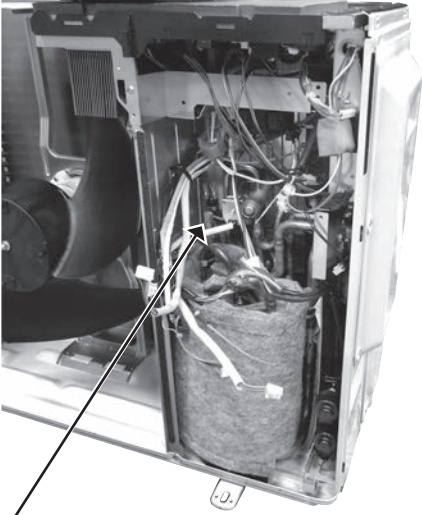

Photo 10





OPERATING PROCEDURE	PHOTOS/FIGURES
<p>5. Removing the expansion valve</p> <p>NOTE: Gas recovery is not required if the unit is pumped down.</p> <ol style="list-style-type: none">(1) Remove the top panel and the service panel (Refer to section 1).(2) Disconnect the power supply cord and indoor/outdoor connecting wires.(3) Remove all the LEV coils.(4) Detach all the brazed parts of the expansion valves and pipes.	<p>Photo 11</p>  <p>LEV coils</p> <p>Expansion valves</p>
<p>6. Before using the service port (High pressure side)</p> <ol style="list-style-type: none">(1) Remove the service panel (Photo 1).(2) Disconnect the power supply cord and indoor/outdoor connecting wires.(3) Remove the top panel, the cabinet, and the back panel (Photo 1, 2, 3).(4) Disconnect all the connectors and the lead wires on the outdoor control P.C. board.(5) Remove all the screws of outdoor control P.C. board holder, and remove the outdoor control P.C. board holder (Photo 5).(6) Make sure that the service port is visible.	<p>Photo 12</p>  <p>Service port (High pressure side)</p>

- 13-2. MXZ-3C24NA MXZ-3C30NA MXZ-4C36NA
 MXZ-3C24NA2 MXZ-3C30NA2 MXZ-4C36NA2
 MXZ-3C24NA3 MXZ-3C30NA3 MXZ-4C36NA3
 MXZ-3C24NA4 MXZ-3C30NA4 MXZ-4C36NA4

Photos: MXZ-4C36NA MXZ-4C36NA2 MXZ-4C36NA3 MXZ-4C36NA4

NOTE: Turn OFF the power supply before disassembly.

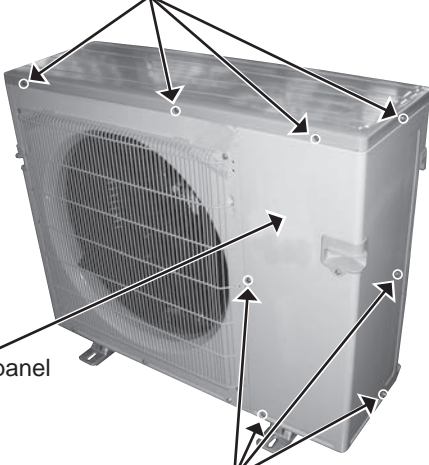
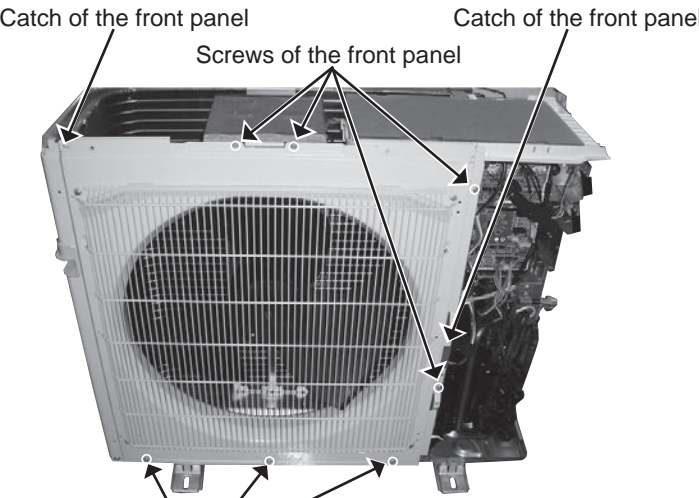
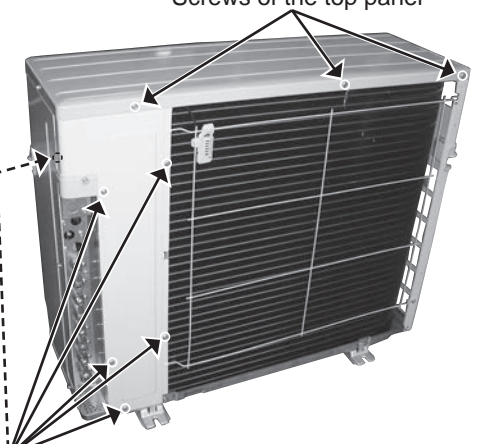
OPERATING PROCEDURE	PHOTOS/FIGURES
<p>1. Removing the panels</p> <ol style="list-style-type: none"> (1) Remove all the screws fixing the top panel, and remove the top panel. (2) Remove all the screws fixing the service panel. (3) Pull down on the service panel, and remove the service panel. (4) Disconnect the power supply cord and indoor/outdoor connecting wires. (5) Remove all the screws fixing the front panel, and remove the front panel. (6) Remove all the screws fixing the back panel, and remove the back panel. 	<p>Photo 1 Screws of the top panel</p>  <p>Service panel</p> <p>Screws of the service panel</p>
<p>Photo 3</p>  <p>Catch of the front panel Catch of the front panel</p> <p>Screws of the front panel</p> <p>Screws of the front panel</p>	<p>Photo 2 Screws of the top panel</p>  <p>Screws of the back panel</p>

OPERATING PROCEDURE

2. Removing the outdoor control P.C. board, the reactor, the outdoor power P.C. board, and the heatsink

- (1) Remove the top panel and the service panel (Refer to section 1).
- (2) Disconnect the power supply cord and indoor/outdoor connecting wires.
- (3) Disconnect the wire-to-wire connector of the compressor lead wire (Photo 4).
- (4) Disconnect all the connectors on the outdoor control P.C. board.
- (5) Remove the releasable cable tie securing the lead wires of core, TBE1, CNTH2, and CNAC2 (Photo 4).
- (6) Remove all the screws fixing the outdoor control P.C. board holder (Photo 4).
- (7) Remove the lead wires of TBE1, CNTH2, and CNAC2 from the right hook on the top of the outdoor control P.C. board holder (Photo 4, Ⓐ).
- (8) Remove the lead wires of CN151 and CN152 from the left hooks on the top and the bottom of the outdoor control P.C. board holder (Photo 4, Ⓑ and 5).
- (9) Remove the outdoor control P.C. board holder.
- (10) Disengage all the catches of the outdoor control P.C. board holder, and remove the outdoor control P.C. board (Photo 6).
- (11) Disconnect all the lead wires from the reactor (Photo 7).
- (12) Remove all the screws fixing the reactor, and remove the reactor (Photo 7).
- (13) Remove all the lead wires from the clamps on the separator (Photo 8).

PHOTOS/FIGURES

Photo 6

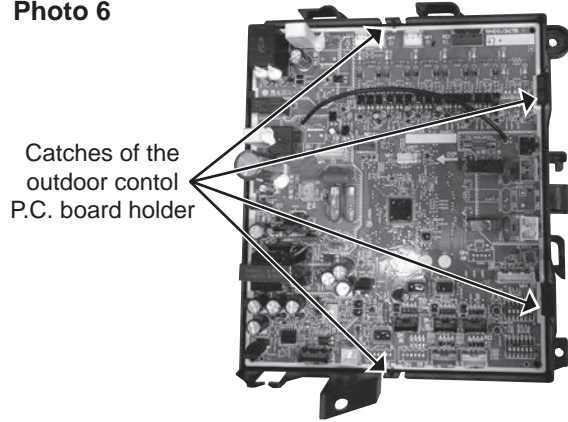

Photo 7

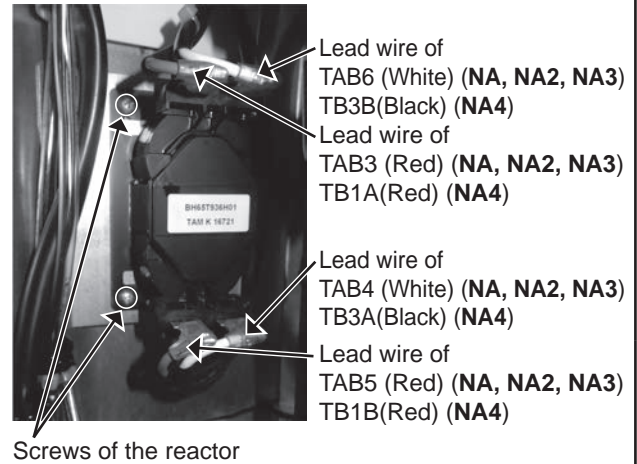
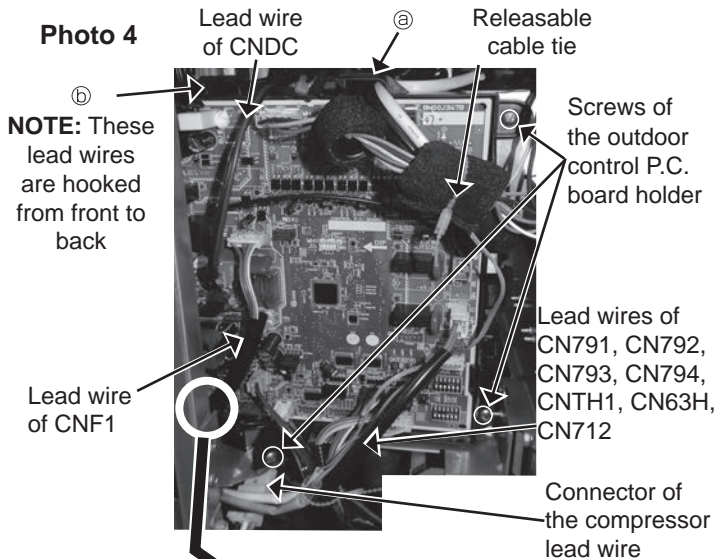

Photo 4



NOTE: These lead wires are hooked from front to back

Photo 5

Left hook on the bottom of control P.C. board (CN151, CN152)

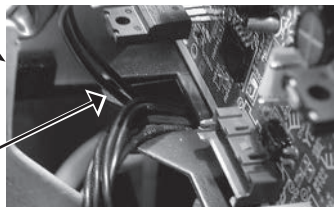
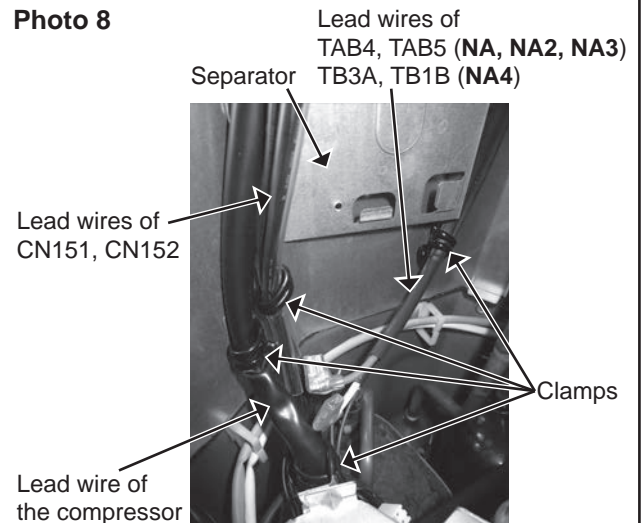

Photo 8



OPERATING PROCEDURE

- (14) Disengage all the catches of the PB cover, and remove the PB cover (Photo 9).
- (15) Remove the screw fixing the outdoor power P.C. board and all the screws fixing the outdoor power P.C. board and the heatsink (Photo 10).
- (16) Disengage all the catches of the outdoor power P.C. board, and lift the outdoor power P.C. board (Photo 10).
- (17) While lifting the outdoor power P.C. board, disconnect the lead wires, the connectors, and the earth wires; then remove the outdoor power P.C. board (Photo 11).
NOTE: When reassembling, pass the lead wire of the CN171 through the notch and behind the lead wire of the compressor (Photo 12).
- (18) Remove all the screws of the heatsink fixing parts and remove the heatsink fixing parts (Photo 13).
- NOTE:** Some units have only 1 heatsink fixing part.
- (19) Remove the heatsink.

PHOTOS/FIGURES

Photo 9

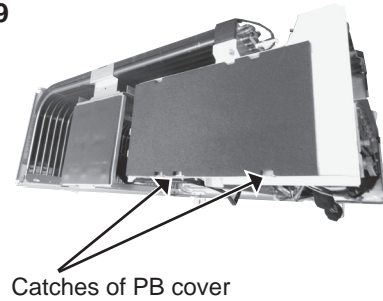

Catches of PB cover

Photo 10

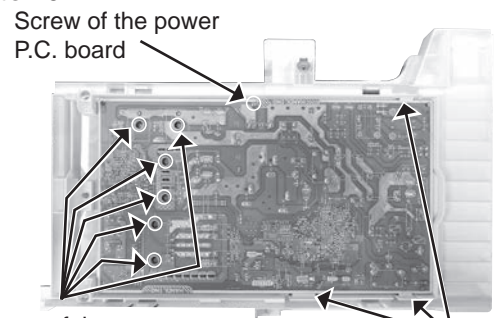

Screw of the power P.C. board

Screws of the power P.C. board and the heatsink

Catches of the power P.C. board

Photo 11
(NA, NA2, NA3)

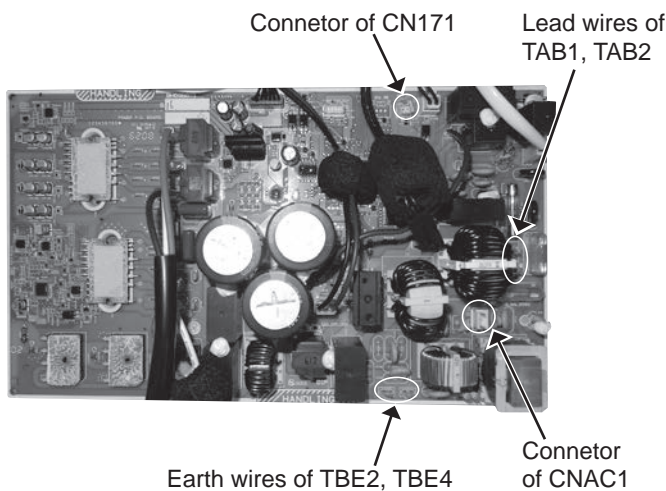

Connector of CN171

Lead wires of TAB1, TAB2

Earth wires of TBE2, TBE4

Connector of CNAC1

(NA4)

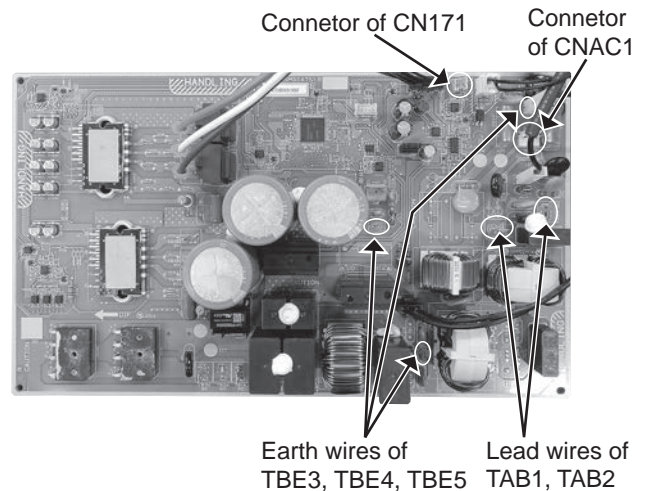

Connector of CN171

Connector of CNAC1

Earth wires of TBE3, TBE4, TBE5

Lead wires of TAB1, TAB2

OPERATING PROCEDURE

Photo 12
(NA, NA2, NA3)

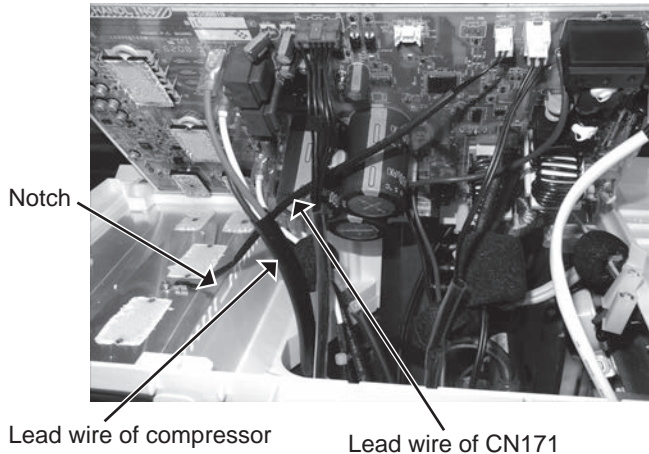

(NA4)

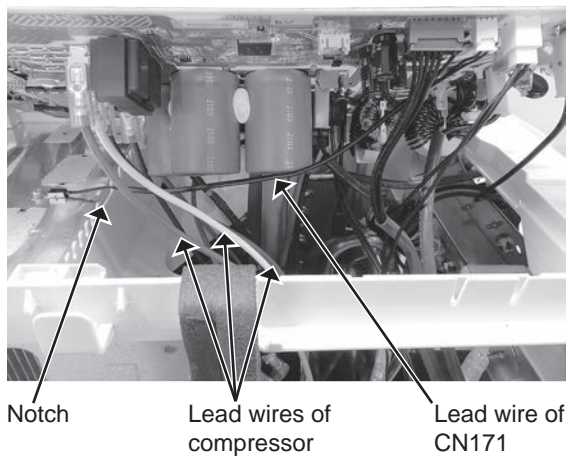

PHOTOS/FIGURES

Photo 13

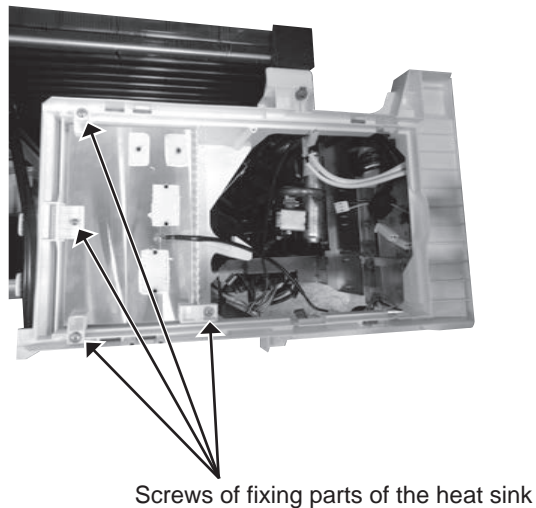

3. Removing the fan motor

- (1) Remove the top panel, the service panel, and the front panel (Refer to section 1).
- (2) Disconnect the power supply cord and indoor/outdoor connecting wires.
- (3) Disconnect the connector of CNF1 on the outdoor control P.C. board.
- (4) Remove the propeller fan.
- (5) Remove the fan motor.

NOTE: The propeller fan nut is a reverse thread.

Photo 14

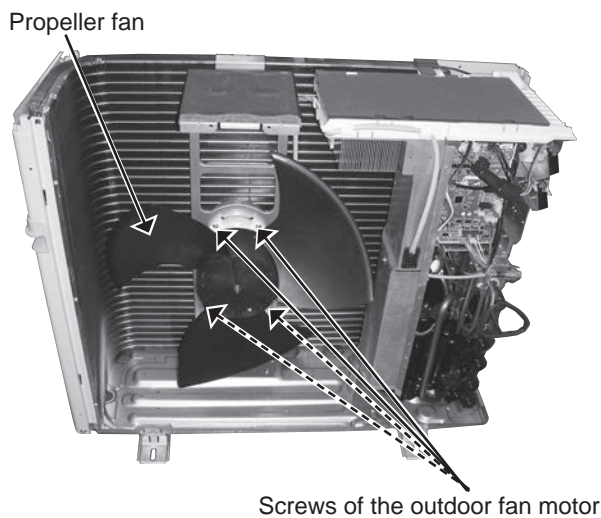

OPERATING PROCEDURE

4. Removing the compressor and 4-way valve

- (1) Remove the top panel, the service panel, and the front panel (Refer to section 1).
- (2) Disconnect the power supply cord and indoor/outdoor connecting wires, and remove the back panel.
- (3) Recover gas from the refrigerant circuit.

NOTE: Recover gas from the pipes until the pressure gauge shows 0 PSIG.

- (4) Disconnect the compressor lead wire from the terminal of the compressor (U, V, W).
- (5) Disconnect the outdoor control P.C. board connectors: CNF1, CNTH1, CNTH2, CN63H, CN712, CN791, CN792, CN793, CN794 (**MXZ-4C**)
- (6) Remove all the screws fixing the electrical parts, and remove the electrical parts.
- (7) Remove the propeller fan.
- (8) Remove all the screws fixing the separator, and remove the separator.
- (9) Remove the sound proof felt.
- (10) Detach all the brazed parts of the compressor suction and discharge pipes (Photo 17).
- (11) Remove all the compressor nuts and remove the compressor (Photo 17).
- (12) Detach all the brazed parts of 4-way valve and pipes.

PHOTOS/FIGURES

Photo 15

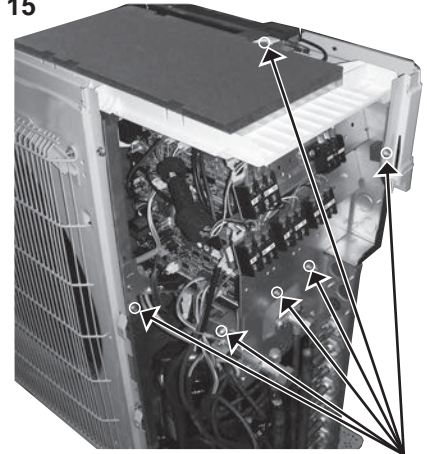

Screws of the electrical parts

Photo 16

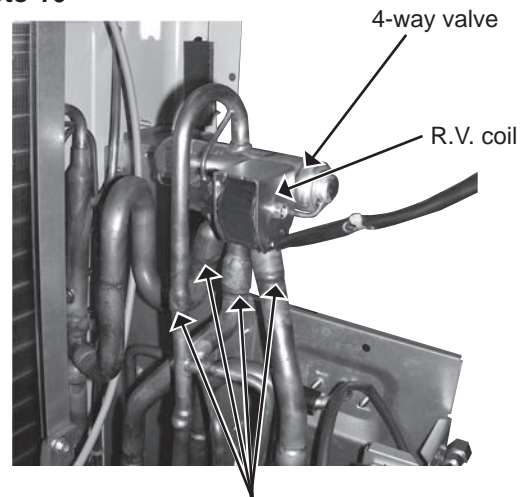

Brazed parts

5. Removing the expansion valve

NOTE: Gas recovery is not required if the unit is pumped down.

- (1) Remove the top panel and the service panel (Refer to section 1).
- (2) Disconnect the power supply cord and indoor/outdoor connecting wires.
- (3) Remove all the LEV coils.

NOTE: When reassembling, to secure the LEV coils on the pipe, make sure to use the metal clips for proper positioning.

- (4) Detach all the brazed parts of the expansion valves and pipes.

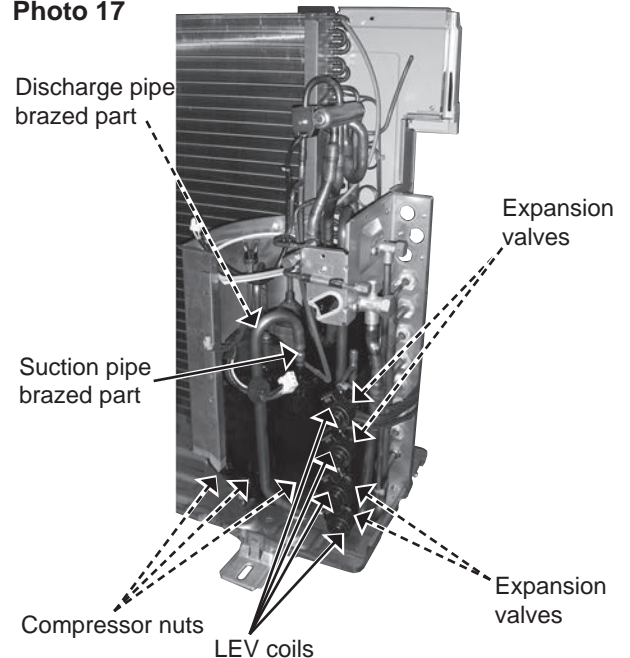
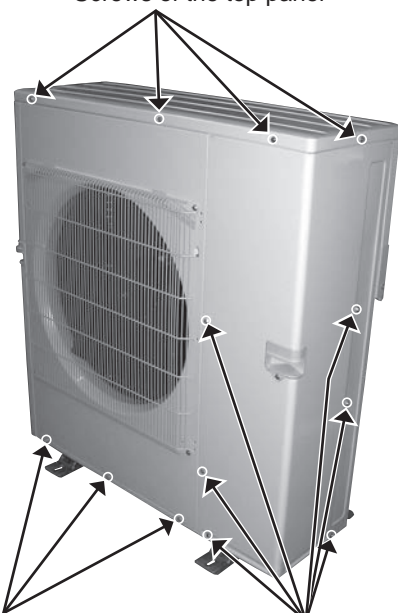

Photo 17



13-3. MXZ-5C42NA MXZ-2C20NAHZ MXZ-3C24NAHZ MXZ-3C30NAHZ
 MXZ-5C42NA2 MXZ-2C20NAHZ2 MXZ-3C24NAHZ2 MXZ-3C30NAHZ2
 MXZ-5C42NA3 MXZ-2C20NAHZ3 MXZ-3C24NAHZ3 MXZ-3C30NAHZ3
 MXZ-5C42NA4 MXZ-2C20NAHZ4 MXZ-3C24NAHZ4 MXZ-3C30NAHZ4

Photos: MXZ-3C30NAHZ MXZ-3C30NAHZ2 MXZ-3C30NAHZ3 MXZ-3C30NAHZ4

NOTE: Turn OFF the power supply before disassembly.

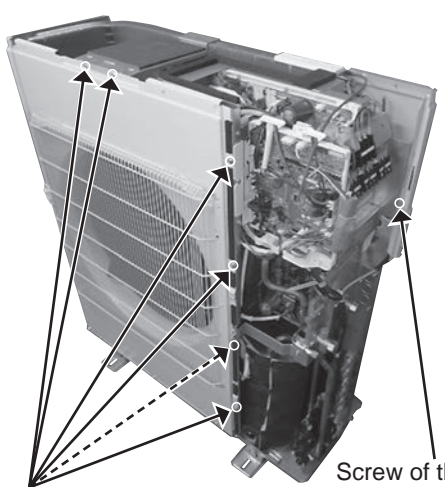
OPERATING PROCEDURE	PHOTOS/FIGURES
<p>1. Removing the panels</p> <ol style="list-style-type: none"> (1) Remove all the screws fixing the top panel, and remove the top panel. (2) Remove all the screws fixing the service panel. (3) Pull down on the service panel, and remove the service panel. (4) Disconnect the power supply cord and indoor/outdoor connecting wires. (5) Remove all the screws fixing the front panel, and remove the front panel. (6) Remove all the screws fixing the back panel, and remove the back panel. 	<p>Photo 1</p> <p>Screws of the top panel</p>  <p>Screws of the front panel Screws of the service panel</p> <p>Photo 2</p> <p>Screws of the top panel</p>  <p>Screws of the back panel</p> <p>Photo 3</p>  <p>Screws of the front panel Screw of the back panel</p>

OPERATING PROCEDURE

2. Removing the outdoor control P.C. board, the reactor and the outdoor power P.C. board

- (1) Remove the top panel, the service panel and the front panel (Refer to section 1).
- (2) Disconnect the power supply cord and indoor/outdoor connecting wires.
- (3) Disconnect all the connectors on the outdoor control P.C. board.
- (4) Remove all the screws fixing the outdoor control P.C. board, and remove the outdoor control P.C. board.
- (5) Remove all the screws fixing the electrical parts, and remove the electrical parts.
- (6) Remove all the screws fixing the TB support, and remove the TB support.
- (7) Remove all the screws fixing the control box separator, and remove the control box separator.
- (8) Disconnect the lead wire of the outdoor power P.C. board.
- (9) Remove all the screws fixing the outdoor power P.C. board, and remove the outdoor power P.C. board with the outdoor P.C. board holder.
- (10) Remove all the screws fixing the control box F, and remove the control box F.
- (11) Remove all the screws fixing the reactors, and remove the reactors.

PHOTOS/FIGURES

Photo 4

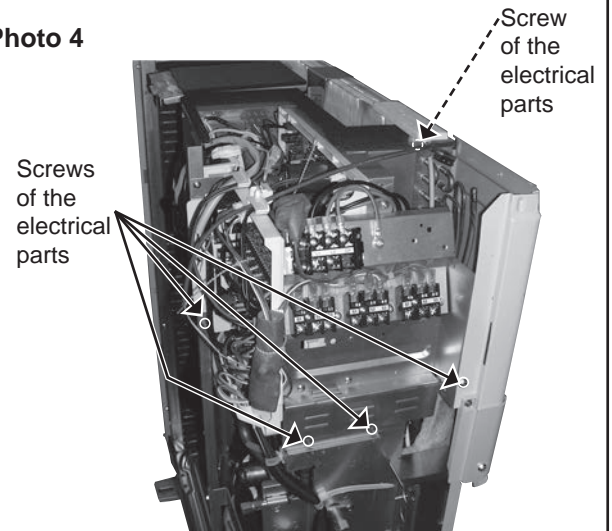

Photo 5

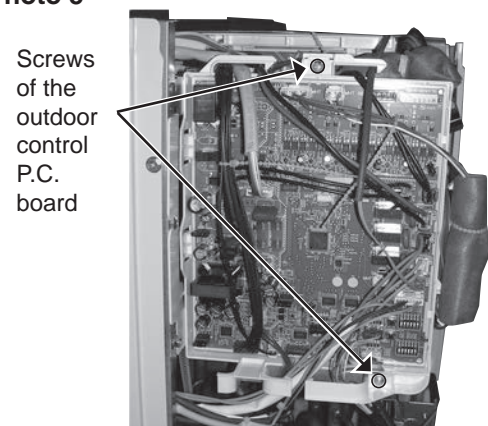

Photo 6

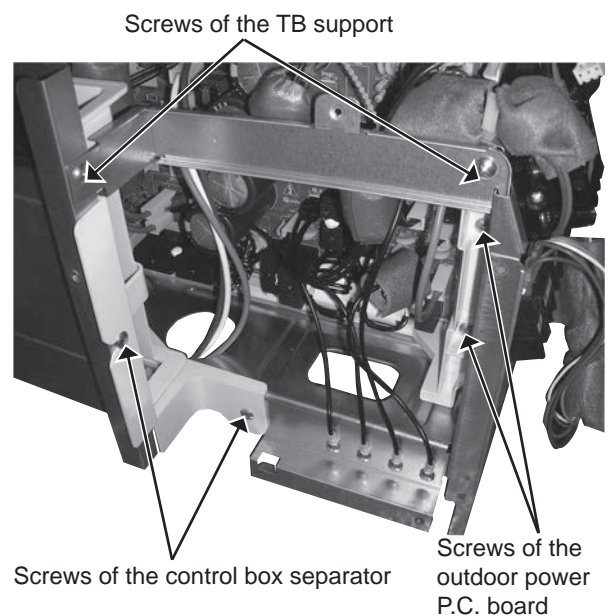

Photo 7

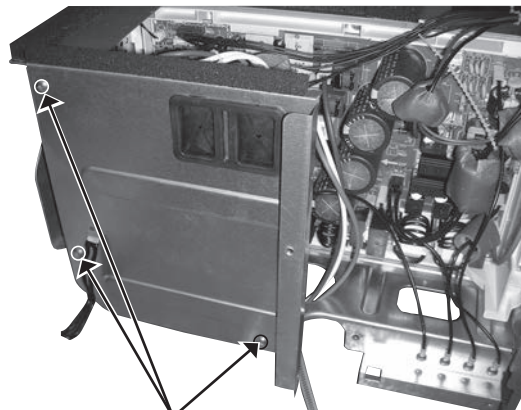
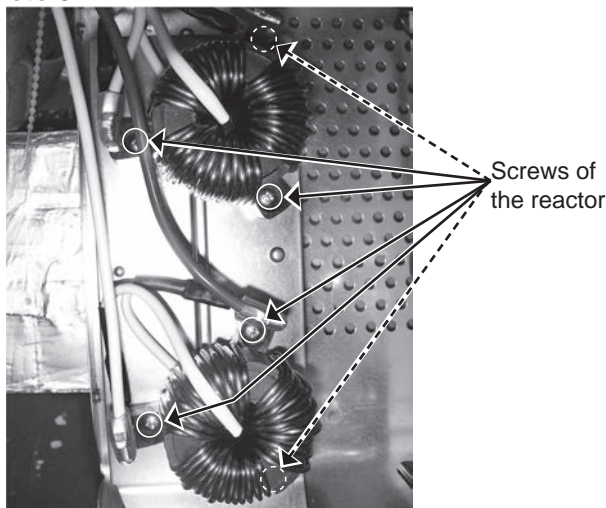

Photo 8



OPERATING PROCEDURE

3. Removing the fan motor

- (1) Remove the top panel, the service panel, and the front panel (Refer to section 1).
- (2) Disconnect the power supply cord and indoor/outdoor connecting wires.
- (3) Disconnect the connector of CNF1 on the outdoor control P.C. board.
- (4) Remove the propeller fan.
- (5) Remove the fan motor.

NOTE: The propeller fan nut is a reverse thread.

4. Removing the compressor and 4-way valve

- (1) Remove the top panel, the service panel and the front panel.
- (2) Disconnect the power supply cord and indoor/outdoor connecting wires, and remove the back panel.
- (3) Recover gas from the refrigerant circuit.
NOTE: Recover gas from the pipes until the pressure gauge shows 0 PSIG.
- (5) Disconnect the compressor lead wire from the terminal of the compressor (U, V, W).
- (6) Disconnect the outdoor control P.C. board connectors: CNF1, CNTH1, CNTH2, CN63H, CN712, CN713, CN714 (MXZ-C-NAHZ, MXZ-C-NAHZ2, MXZ-C-NAHZ3, MXZ-C-NAHZ4), CN791, CN792, CN793 (MXZ-5C42NA, MXZ-3C24/30NAHZ, MXZ-5C42NA2, MXZ-3C24/30NAHZ2, MXZ-5C42NA3, MXZ-3C24/30NAHZ3, MXZ-5C42NA4, MXZ-3C24/30NAHZ4), CN794, CN795 (MXZ-5C42NA, MXZ-5C42NA2, MXZ-5C42NA3, MXZ-5C42NA4)
- (7) Remove all the screws fixing the electrical parts, and remove the electrical parts (Photo 4).
- (8) Remove the propeller fan.
- (9) Remove all the screws fixing the VB fixture, and remove the VB fixture.
- (10) Remove all the screws fixing the separator, and remove the separator.
NOTE: When installing the separator, insert the tabs of the heat exchanger into the separator.
- (11) Remove all the sound proof felts.
- (12) Detach all the brazed parts of the suction and discharge pipes (Photo 11).
- (13) Remove all the compressor nuts, and remove the compressor (Photo 11).
- (14) Detach all the brazed parts of 4-way valve and pipes.

PHOTOS/FIGURES

Photo 9

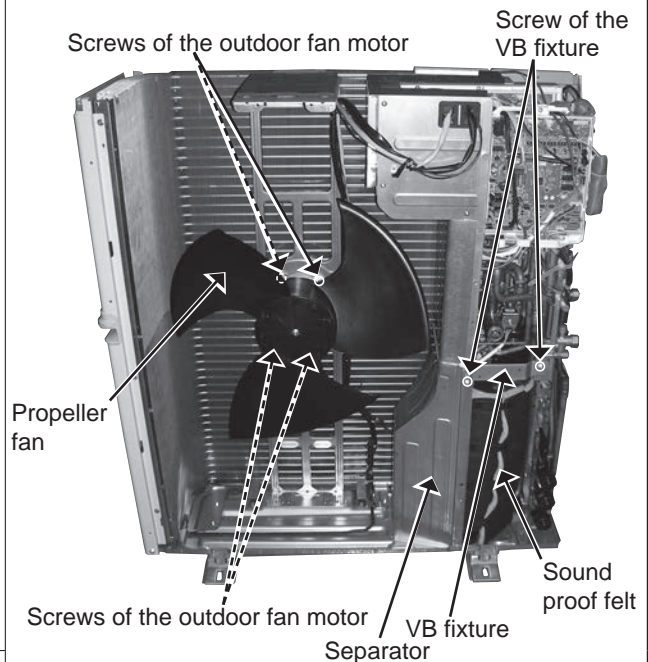
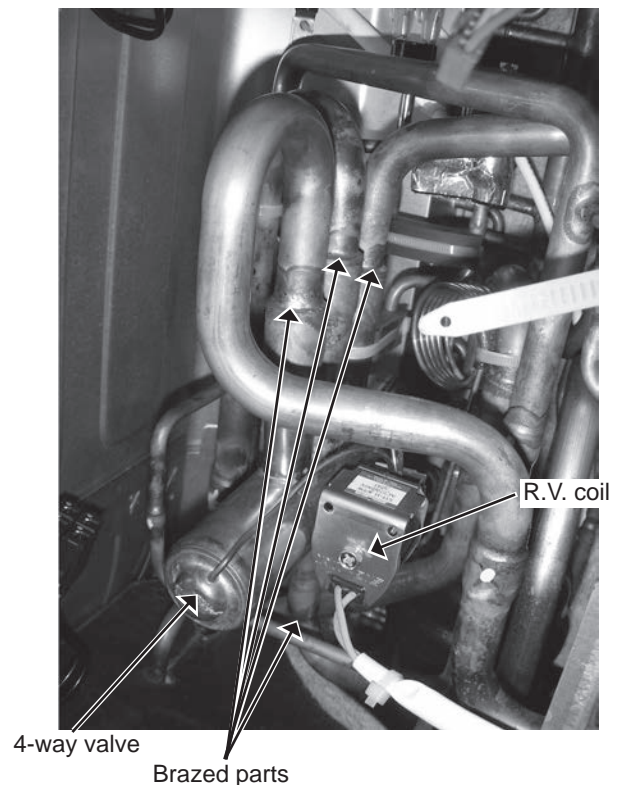

Photo 10



OPERATING PROCEDURE

5. Removing the expansion valve

NOTE: Gas recovery is not required if the unit is pumped down.

- (1) Remove the top panel and the service panel (Refer to section 1).
- (2) Disconnect the power supply cord and indoor/outdoor connecting wires.
- (3) Remove all the LEV coils.
- (4) Detach all the brazed parts of the expansion valves and pipes.

PHOTOS/FIGURES

Photo 11

Discharge pipe
brazed part

Suction pipe
brazed part



Compressor nuts

LEV coils

Expansion
valves

mitsubishi electric corporation

HEAD OFFICE: TOKYO BUILDING, 2-7-3, MARUNOUCHI, CHIYODA-KU, TOKYO 100-8310, JAPAN

© Copyright 2014 MITSUBISHI ELECTRIC CORPORATION

Issued: Nov. 2022. No. OBH702 REVISED EDITION-P

Issued: Oct. 2022. No. OBH702 REVISED EDITION-N

Issued: Aug. 2022. No. OBH702 REVISED EDITION-M

Issued: Jun. 2022. No. OBH702 REVISED EDITION-L

Issued: Dec. 2021. No. OBH702 REVISED EDITION-K

Issued: Jul. 2021. No. OBH702 REVISED EDITION-J

Issued: Nov. 2020. No. OBH702 REVISED EDITION-H

Issued: Oct. 2018. No. OBH702 REVISED EDITION-G

Issued: Apr. 2017. No. OBH702 REVISED EDITION-F

Issued: Dec. 2016. No. OBH702 REVISED EDITION-E

Issued: Jul. 2016. No. OBH702 REVISED EDITION-D

Issued: Mar. 2016. No. OBH702 REVISED EDITION-C

Issued: Feb. 2016. No. OBH702 REVISED EDITION-B

Issued: Oct. 2014. No. OBH702 REVISED EDITION-A

Published: Sep. 2014. No. OBH702

Made in Japan

Specifications are subject to change without notice.