



© 2020 Lennox Industries Inc.  
Dallas, Texas USA



# INSTALLATION INSTRUCTIONS ML296UHV

**MERIT® SERIES GAS FURNACE  
UPFLOW / HORIZONTAL AIR DISCHARGE**

507869-03  
06/2020  
Supersedes 05/2020



**THIS MANUAL MUST BE LEFT WITH THE  
HOMEOWNER FOR FUTURE REFERENCE**

**!** This is a safety alert symbol and should never be ignored. When you see this symbol on labels or in manuals, be alert to the potential for personal injury or death.

## **!** WARNING

Improper installation, adjustment, alteration, service or maintenance can cause property damage, personal injury or loss of life. Installation and service must be performed by a licensed professional HVAC installer (or equivalent), service agency or the gas supplier.

## **!** CAUTION

As with any mechanical equipment, contact with sharp sheet metal edges can result in personal injury. Take care while handling this equipment and wear gloves and protective clothing.

### Contents

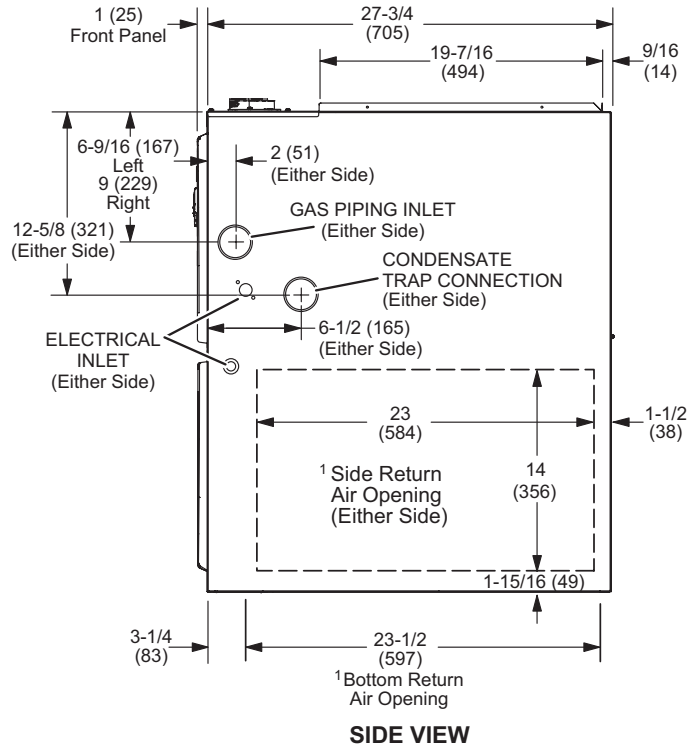
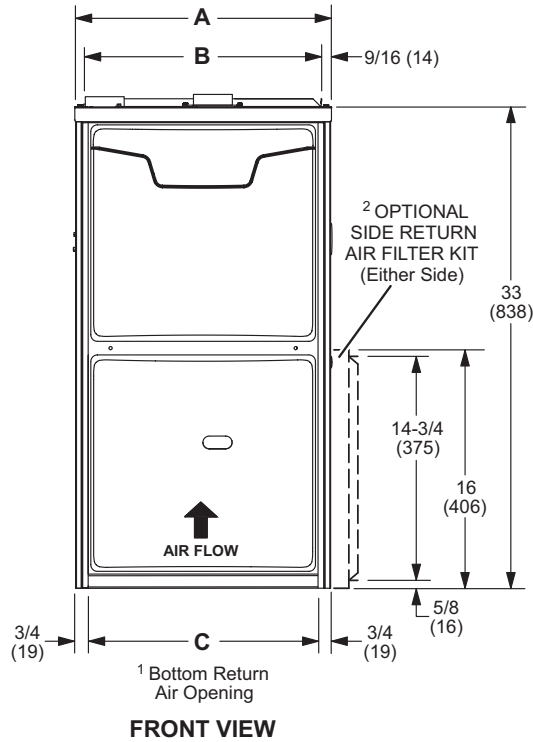
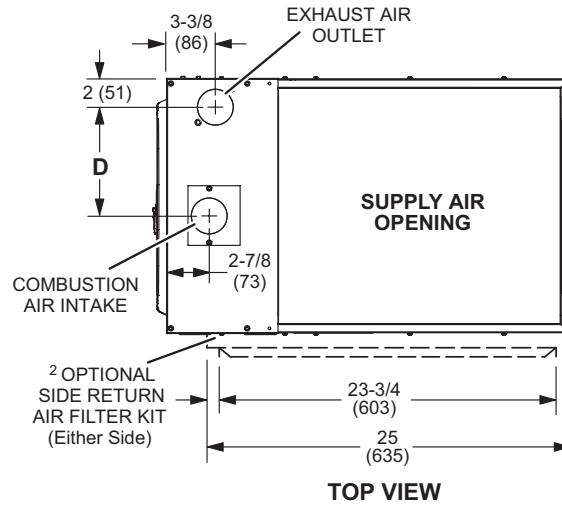
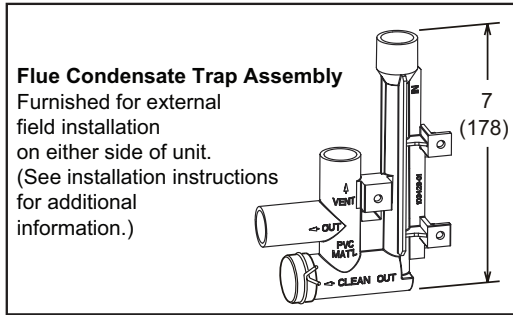
Unit Dimensions - inches (mm) .....	2	Venting Practices .....	16
ML296UHV Gas Furnace .....	3	Gas Piping .....	36
Shipping and Packing List .....	4	Electrical .....	39
Safety .....	3	Blower Motor Performance .....	42
Use of Furnace as a Construction Heater .....	4	Integrated Control .....	47
General .....	5	Unit Start-Up .....	48
Combustion, Dilution, Ventilation Air .....	5	Gas Pressure Measurement .....	49
Setting Equipment .....	8	Proper Combustion .....	50
Filters .....	13	High Altitude .....	50
Duct System .....	11	Repair Parts List .....	51
Pipe Fittings Specifications .....	14	Sequence of Operation .....	52
Joint Cementing Procedure .....	15	Service .....	53



**Unit Dimensions - inches (mm)**

- <sup>1</sup> NOTE - 60C size units that require air volumes over 1800 cfm must have one of the following:
1. Single side return air and Optional Return Air Base with transition that must accommodate required 20 x 25 x 1 inch (508 x 635 x 25 mm) air filter to maintain proper velocity.
  2. Bottom return air.
  3. Return air from both sides.
  4. Bottom and one side return air.
- See Blower Performance Tables for additional information.

<sup>2</sup> Optional Side Return Air Filter Kit is not for use with the Optional Return Air Base.



Model	A	B	C	D
ML296UH045XV36B ML296UH070XV36B	17-1/2 in 446 mm	16-3/8 in 416 mm	16 in 406 mm	7-5/8 in 194 mm
ML296UH090XV48C ML296UH110XV60C	21 in 533 mm	19-7/8 in 505 mm	19-1/2 in 495 mm	9-3/8 in 238 mm

## ML296UHV Gas Furnace

The ML296UHV Category IV gas furnace is shipped ready for installation in the upflow or horizontal position. The furnace is shipped with the bottom panel in place. The bottom panel must be removed if the unit is to be installed in horizontal or upflow applications with bottom return air.

**The ML296UHV can be installed as either a Direct Vent or a Non-Direct Vent gas central furnace.**

The furnace is equipped for installation in natural gas applications. A conversion kit (ordered separately) is required for use in propane/LP gas applications.

**NOTE** - In Direct Vent installations, combustion air is taken from outdoors and flue gases are discharged outdoors. In Non-Direct Vent installations, combustion air is taken from indoors or ventilated attic or crawlspace and flue gases are discharged outdoors. See FIGURE 1 and FIGURE 2 for applications involving roof termination.

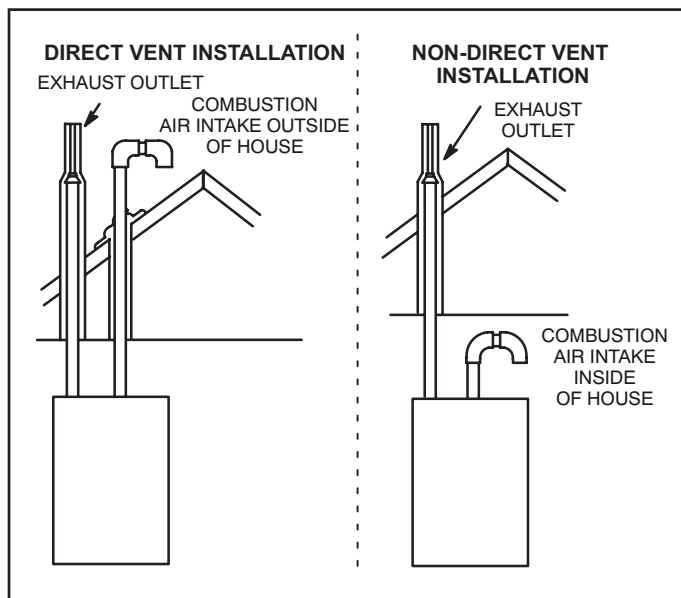


FIGURE 1

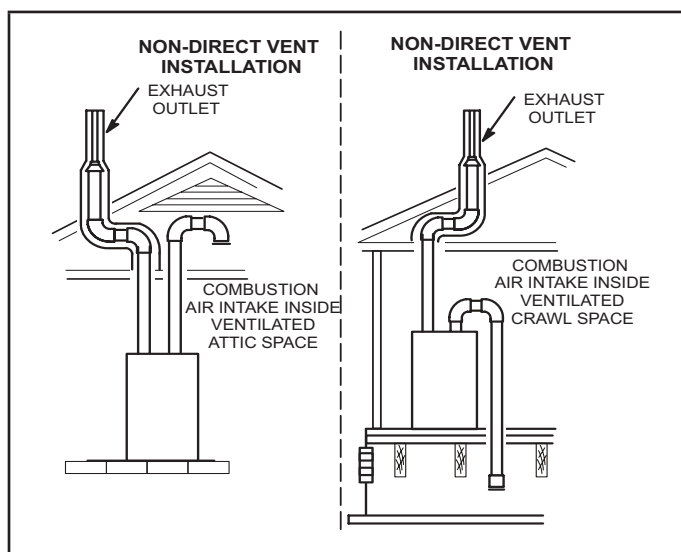


FIGURE 2

## Shipping and Packing List

### Package 1 of 1 contains

- 1 - Assembled ML296UHV unit
- 1 - Bag assembly containing the following:
  - 1 - Snap bushing
  - 1 - Snap plug
  - 1 - Wire tie
  - 1 - Condensate trap
  - 1 - Condensate trap cap
  - 1 - Condensate trap clamp
  - 1 - 2" diameter debris screen
  - 1 - 3/4" Threaded street elbow

Check equipment for shipping damage. If you find any damage, immediately contact the last carrier.

The following items may also be ordered separately:

- 1 - Thermostat
- 1 - LP/Propane changeover kit
- 1 - Return air base kit
- 1 - Horizontal suspension kit
- 1 - High altitude pressure switch

## Safety Information

### CAUTION

As with any mechanical equipment, contact with sharp sheet metal edges can result in personal injury. Take care while handling this equipment and wear gloves and protective clothing.

### DANGER

Danger of explosion.

There are circumstances in which odorant used with LP/propane gas can lose its scent. In case of a leak, LP/propane gas will settle close to the floor and may be difficult to smell. An LP/propane leak detector should be installed in all LP applications.

Use only the type of gas approved for use with this furnace. Refer to unit nameplate.

ML296UHV units are CSA International certified to ANSI Z21.47 and CSA 2.3 standards.

### Building Codes

In the USA, installation of gas furnaces must conform with local building codes. In the absence of local codes, units must be installed according to the current National Fuel Gas Code (ANSI-Z223.1/NFPA 54). The National Fuel Gas Code is available from the following address:

American National Standards Institute, Inc.  
11 West 42nd Street  
New York, NY 10036

In Canada, installation must conform with current National Standard of Canada CSA-B149 Natural Gas and Propane Installation Codes, local plumbing or waste water codes and other applicable local codes.

In order to ensure proper unit operation in non-direct vent applications, combustion and ventilation air supply must be provided according to the current National Fuel Gas Code or CSA-B149 standard.

#### Installation Locations

This furnace is CSA International certified for installation clearances to combustible material as listed on the unit nameplate and in the table in FIGURE 12. Accessibility and service clearances must take precedence over fire protection clearances.

**NOTE - For installation on combustible floors, the furnace shall not be installed directly on carpeting, tile, or other combustible material other than wood flooring.**

For installation in a residential garage, the furnace must be installed so that the burner(s) and the ignition source are located no less than 18 inches (457 mm) above the floor. The furnace must be located or protected to avoid physical damage by vehicles. When a furnace is installed in a public garage, hangar, or other building that has a hazardous atmosphere, the furnace must be installed according to recommended good practice requirements and current National Fuel Gas Code or CSA B149 standards.

**NOTE - Furnace must be adjusted to obtain a temperature rise within the range specified on the unit nameplate. Failure to do so may cause erratic limit operation and premature heat exchanger failure.**

This ML296UHV furnace must be installed so that its electrical components are protected from water.

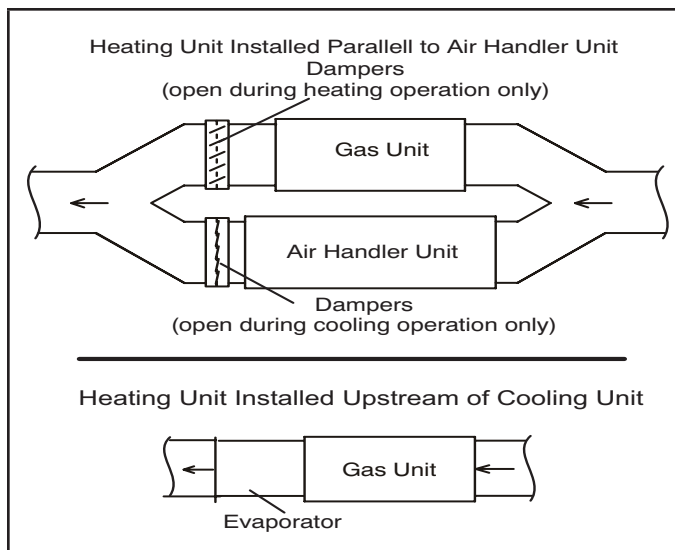
#### Installed in Combination with a Cooling Coil

When this furnace is used with cooling coils (FIGURE 3), it shall be installed in parallel with, or on the upstream side of, cooling coils to avoid condensation in the heating compartment. With a parallel flow arrangement, a damper (or other means to control the flow of air) must adequately prevent chilled air from entering the furnace. If the damper is manually operated, it must be equipped to prevent operation of either the heating or the cooling unit, unless it is in the full **HEAT** or **COOL** setting.

When installed, this furnace must be electrically grounded according to local codes. In addition, in the United States, installation must conform with the current National Electric Code, ANSI/NFPA No. 70. The National Electric Code (ANSI/NFPA No. 70) is available from the following address:

National Fire Protection Association  
1 Battery March Park  
Quincy, MA 02269

In Canada, all electrical wiring and grounding for the unit must be installed according to the current regulations of the Canadian Electrical Code Part I (CSA Standard C22.1) and/or local codes.



**FIGURE 3**

**NOTE - This furnace is designed for a minimum continuous return air temperature of 60°F (16°C) or an intermittent operation down to 55°F (13°C) dry bulb for cases where a night setback thermostat is used. Return air temperature must not exceed 85°F (29°C) dry bulb.**

The ML296UHV furnace may be installed in alcoves, closets, attics, basements, garages, crawl spaces and utility rooms in the upflow or horizontal position.

This furnace design has not been CSA certified for installation in mobile homes, recreational vehicles, or outdoors.

#### Use of Furnace as Construction Heater

Units may be used for heating of buildings or structures under construction, if the following conditions are met to ensure proper operation:

**DO NOT USE THE UNIT FOR CONSTRUCTION HEAT UNLESS ALL OF THE FOLLOWING CRITERIA ARE MET:**

- Furnace must be in its final location. The vent system must be permanently installed per these installation instructions.
- Furnace must be installed as a two pipe system and one hundred percent (100%) outdoor air must be provided for combustion air requirements during construction.
- A room thermostat must control the furnace. The use of fixed jumpers that will provide continuous heating is prohibited.
- The input rate and temperature rise must be set per the furnace rating plate.
- Supply and Return air ducts must be provided and sealed to the furnace. Return air must be terminated outside of the space where furnace is installed.
- Return air temperature range between 60°F (16°C) and 80°F (27°C) must be maintained.
- MERV 11 or greater air filters must be installed in the system and must be regularly inspected and maintained (e.g., regular static checks and replaced at end of life) during construction.

- Blower and vestibule access panels must be in place on the furnace at all times.
- The furnace heat exchanger, components, duct system, and evaporator coils must be thoroughly cleaned following final construction clean-up.
- Air filters must be replaced upon construction completion.
- All furnace operating conditions (including ignition, input rate, temperature rise and venting) must be verified in accordance with these installation instructions.

**EQUIPMENT MAY EXPERIENCE PREMATURE COMPONENT FAILURE AS A RESULT OF FAILURE TO FOLLOW THE ABOVE INSTALLATION INSTRUCTIONS. FAILURE TO FOLLOW THE ABOVE INSTALLATION INSTRUCTIONS VOIDS THE MANUFACTURER'S EQUIPMENT LIMITED WARRANTY. LENNOX DISCLAIMS ALL LIABILITY IN CONNECTION WITH INSTALLER'S FAILURE TO FOLLOW THE ABOVE INSTALLATION INSTRUCTIONS.**

**NOTWITHSTANDING THE FOREGOING, INSTALLER IS RESPONSIBLE FOR CONFIRMING THAT THE USE OF CONSTRUCTION HEAT IS CONSISTENT WITH THE POLICIES AND CODES OF ALL REGULATING ENTITIES. ALL SUCH POLICIES AND CODES MUST BE ADHERED TO.**

**General**

These instructions are intended as a general guide and do not supersede local codes in any way. Consult authorities having jurisdiction before installation.

In addition to the requirements outlined previously, the following general recommendations must be considered when installing a ML296UHV furnace:

- Place the furnace as close to the center of the air distribution system as possible. The furnace should also be located close to the vent termination point.
- When the furnace is installed in non-direct vent applications, do not install the furnace where drafts might blow directly into it. This could cause improper combustion and unsafe operation.
- When the furnace is installed in non-direct vent applications, do not block the furnace combustion air opening with clothing, boxes, doors, etc. Air is needed for proper combustion and safe unit operation.
- When the furnace is installed in an attic or other insulated space, keep insulation away from the furnace.
- When the furnace is installed in an unconditioned space, consider provisions required to prevent freezing of condensate drain system.
- Please consult the manufacturer of your evaporator coil for their recommendations on distance required between the heat exchanger and their drain pan. Adequate space must be provided between the drain pan and the furnace heat exchanger.

**CAUTION**

ML296UHV unit should not be installed in areas normally subject to freezing temperatures.

**WARNING**

Insufficient combustion air can cause headaches, nausea, dizziness or asphyxiation. It will also cause excess water in the heat exchanger resulting in rusting and premature heat exchanger failure. Excessive exposure to contaminated combustion air will result in safety and performance related problems. Avoid exposure to the following substances in the combustion air supply:

- Permanent wave solutions
- Chlorinated waxes and cleaners
- Chlorine base swimming pool chemicals
- Water softening chemicals
- De-icing salts or chemicals
- Carbon tetrachloride
- Halogen type refrigerants
- Cleaning solvents (such as perchloroethylene)
- Printing inks, paint removers, varnishes, etc.
- Hydrochloric acid
- Cements and glues
- Antistatic fabric softeners for clothes dryers
- Masonry acid washing materials

**Combustion, Dilution & Ventilation Air**

If the ML296UHV is installed as a Non-Direct Vent Furnace, follow the guidelines in this section.

NOTE - In Non-Direct Vent installations, combustion air is taken from indoors or ventilated attic or crawlspace and flue gases are discharged out-doors.

In the past, there was no problem in bringing in sufficient outdoor air for combustion. Infiltration provided all the air that was needed. In today's homes, tight construction practices make it necessary to bring in air from outside for combustion. Take into account that exhaust fans, appliance vents, chimneys, and fireplaces force additional air that could be used for combustion out of the house. Unless outside air is brought into the house for combustion, negative pressure (outside pressure is greater than inside pressure) will build to the point that a downdraft can occur in the furnace vent pipe or chimney. As a result, combustion gases enter the living space creating a potentially dangerous situation.

In the absence of local codes concerning air for combustion and ventilation, use the guidelines and procedures in this section to install ML296UHV furnaces to ensure efficient and safe operation. You must consider combustion air needs and requirements for exhaust vents and gas piping.

A portion of this information has been reprinted with permission from the National Fuel Gas Code (ANSI Z223.1/NFPA 54). This reprinted material is not the complete and official position of the ANSI on the referenced subject, which is represented only by the standard in its entirety.

In Canada, refer to the CSA B149 installation codes.

## **⚠ CAUTION**

Do not install the furnace in a corrosive or contaminated atmosphere. Meet all combustion and ventilation air requirements, as well as all local codes.

All gas-fired appliances require air for the combustion process. If sufficient combustion air is not available, the furnace or other appliance will operate inefficiently and unsafely. Enough air must be provided to meet the needs of all fuel-burning appliances and appliances such as exhaust fans which force air out of the house. When fireplaces, exhaust fans, or clothes dryers are used at the same time as the furnace, much more air is required to ensure proper combustion and to prevent a downdraft. Insufficient air causes incomplete combustion which can result in carbon monoxide.

In addition to providing combustion air, fresh outdoor air dilutes contaminants in the indoor air. These contaminants may include bleaches, adhesives, detergents, solvents and other contaminants which can corrode furnace components.

The requirements for providing air for combustion and ventilation depend largely on whether the furnace is installed in an unconfined or a confined space.

### Unconfined Space

An unconfined space is an area such as a basement or large equipment room with a volume greater than 50 cubic feet (1.42 m<sup>3</sup>) per 1,000 Btu (.29 kW) per hour of the combined input rating of all appliances installed in that space. This space also includes adjacent rooms which are not separated by a door. Though an area may appear to be unconfined, it might be necessary to bring in outdoor air for combustion if the structure does not provide enough air by infiltration. If the furnace is located in a building of tight construction with weather stripping and caulking around the windows and doors, follow the procedures in the Air from Outside section.

### Confined Space

A confined space is an area with a volume less than 50 cubic feet (1.42 m<sup>3</sup>) per 1,000 Btu (.29 kW) per hour of the combined input rating of all appliances installed in that space. This definition includes furnace closets or small equipment rooms.

When the furnace is installed so that supply ducts carry air circulated by the furnace to areas outside the space containing the furnace, the return air must be handled by ducts which are sealed to the furnace casing and which terminate outside the space containing the furnace. This is especially important when the furnace is mounted on a platform in a confined space such as a closet or small equipment room.

Even a small leak around the base of the unit at the platform or at the return air duct connection can cause a potentially dangerous negative pressure condition. Air for combustion and ventilation can be brought into the confined space either from inside the building or from outside.

### Air from Inside

If the confined space that houses the furnace adjoins a space categorized as unconfined, air can be brought in by providing two permanent openings between the two spaces. Each opening must have a minimum free area of 1 square inch (645 mm<sup>2</sup>) per 1,000 Btu (.29 kW) per hour of total input rating of all gas-fired equipment in the confined space. Each opening must be at least 100 square inches (64516 mm<sup>2</sup>). One opening shall be within 12 inches (305 mm) of the top of the enclosure and one opening within 12 inches (305 mm) of the bottom. See FIGURE 4.

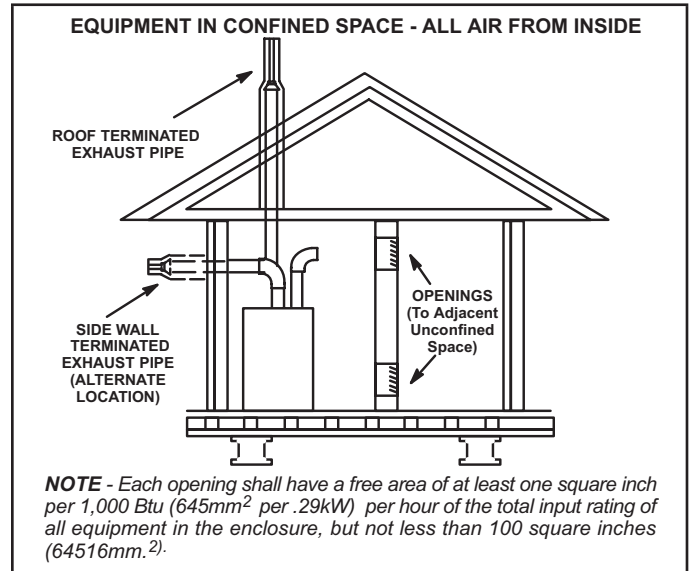


FIGURE 4

## Air from Outside

If air from outside is brought in for combustion and ventilation, the confined space shall be provided with two permanent openings. One opening shall be within 12" (305mm) of the top of the enclosure and one within 12" (305mm) of the bottom. These openings must communicate directly or by ducts with the outdoors or spaces (crawl or attic) that freely communicate with the outdoors or indirectly through vertical ducts. Each opening shall have a minimum free area of 1 square inch per 4,000 Btu (645mm<sup>2</sup> per 1.17kW) per hour of total input rating of all equipment in the enclosure. When communicating with the outdoors through horizontal ducts, each opening shall have a minimum free area of 1 square inch per 2,000 Btu (645mm<sup>2</sup> per .59kW) per total input rating of all equipment in the enclosure (See FIGURE 5). It is also permissible to bring in air for combustion from a ventilated attic (FIGURE 6) or ventilated crawl space (FIGURE 7).

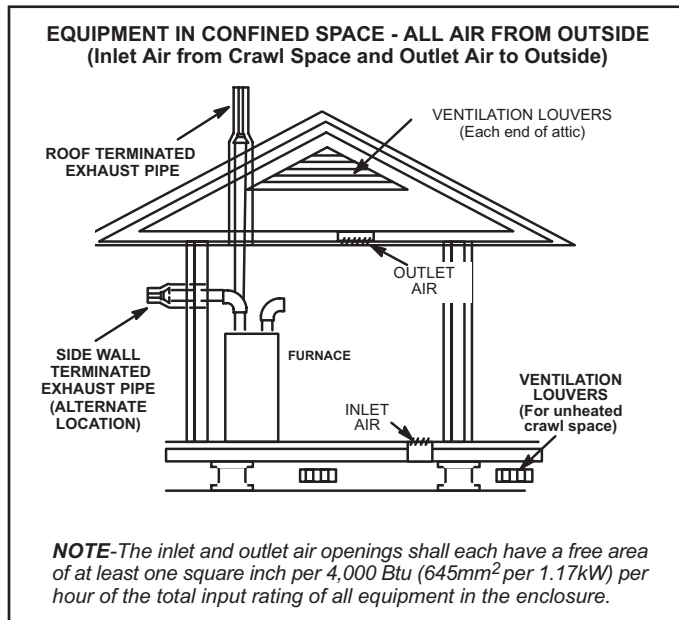


FIGURE 5

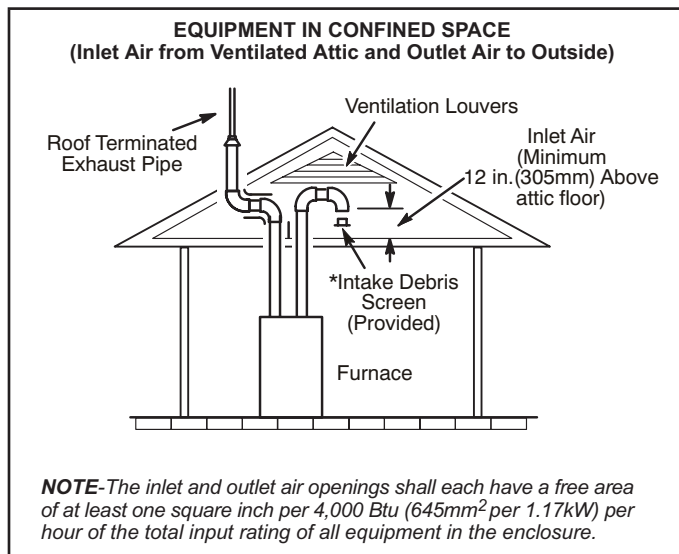


FIGURE 6

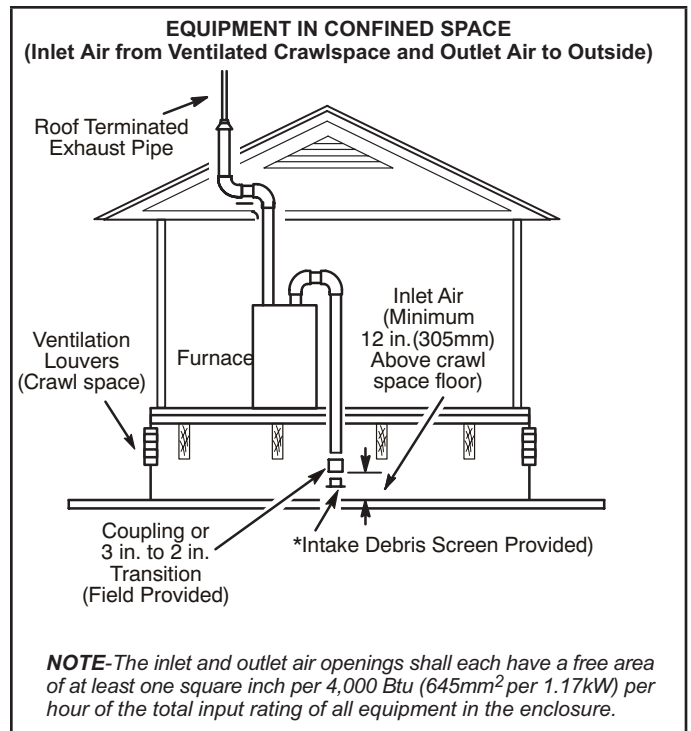
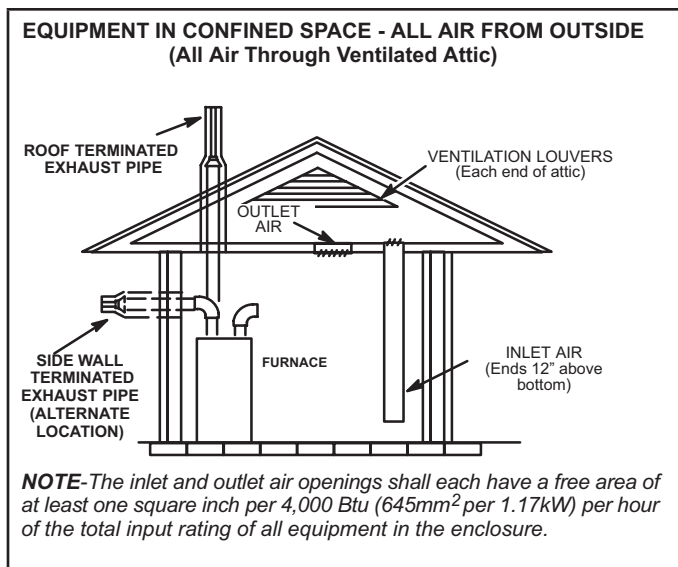


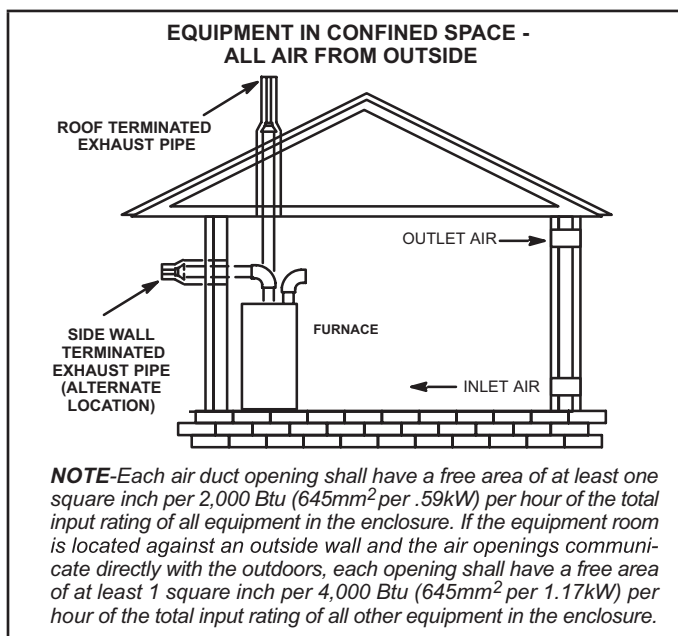
FIGURE 7

If air from outside is brought in for combustion and ventilation, the confined space must have two permanent openings. One opening shall be within 12 inches (305 mm) of the top of the enclosure and one opening within 12 inches (305 mm) of the bottom. These openings must communicate directly or by ducts with the outdoors or spaces (crawl or attic) that freely communicate with the outdoors or indirectly through vertical ducts. Each opening shall have a minimum free area of 1 square inch (645 mm<sup>2</sup>) per 4,000 Btu (1.17 kW) per hour of total input rating of all equipment in the enclosure. See FIGURE 5 and FIGURE 8. When communicating with the outdoors through horizontal ducts, each opening shall have a minimum free area of 1 square inch (645 mm<sup>2</sup>) per 2,000 Btu (.56 kW) per total input rating of all equipment in the enclosure. See figure 9.

When ducts are used, they shall be of the same cross-sectional area as the free area of the openings to which they connect. The minimum dimension of rectangular air ducts shall be no less than 3 inches (75 mm). In calculating free area, the blocking effect of louvers, grilles, or screens must be considered. If the design and free area of protective covering is not known for calculating the size opening required, it may be assumed that wood louvers will have 20 to 25 percent free area and metal louvers and grilles will have 60 to 75 percent free area. Louvers and grilles must be fixed in the open position or interlocked with the equipment so that they are opened automatically during equipment operation.



**FIGURE 8**

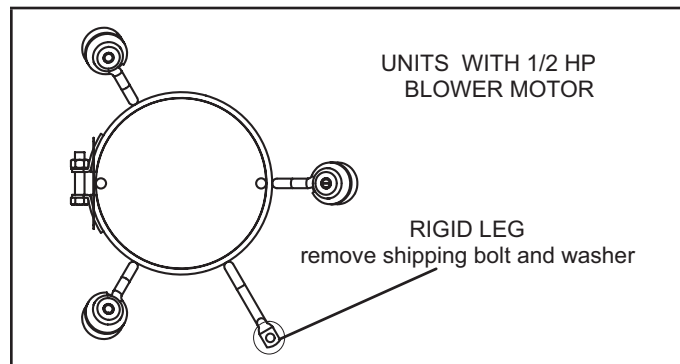


**FIGURE 9**

**Shipping Bolt Removal**

Units with 1/2 hp blower motor are equipped with three flexible legs and one rigid leg. The rigid leg is equipped with a shipping bolt and a flat white plastic washer (rather than the rubber mounting grommet used with a flexible mounting

leg). See FIGURE 10. The bolt and washer must be removed before the furnace is placed into operation. After the bolt and washer have been removed, the rigid leg will not touch the blower housing.



**FIGURE 10**

**Installation - Setting Equipment**

**⚠ WARNING**  
Do not connect the return air duct to the back of the furnace. Doing so will adversely affect the operation of the safety control devices, which could result in personal injury or death.

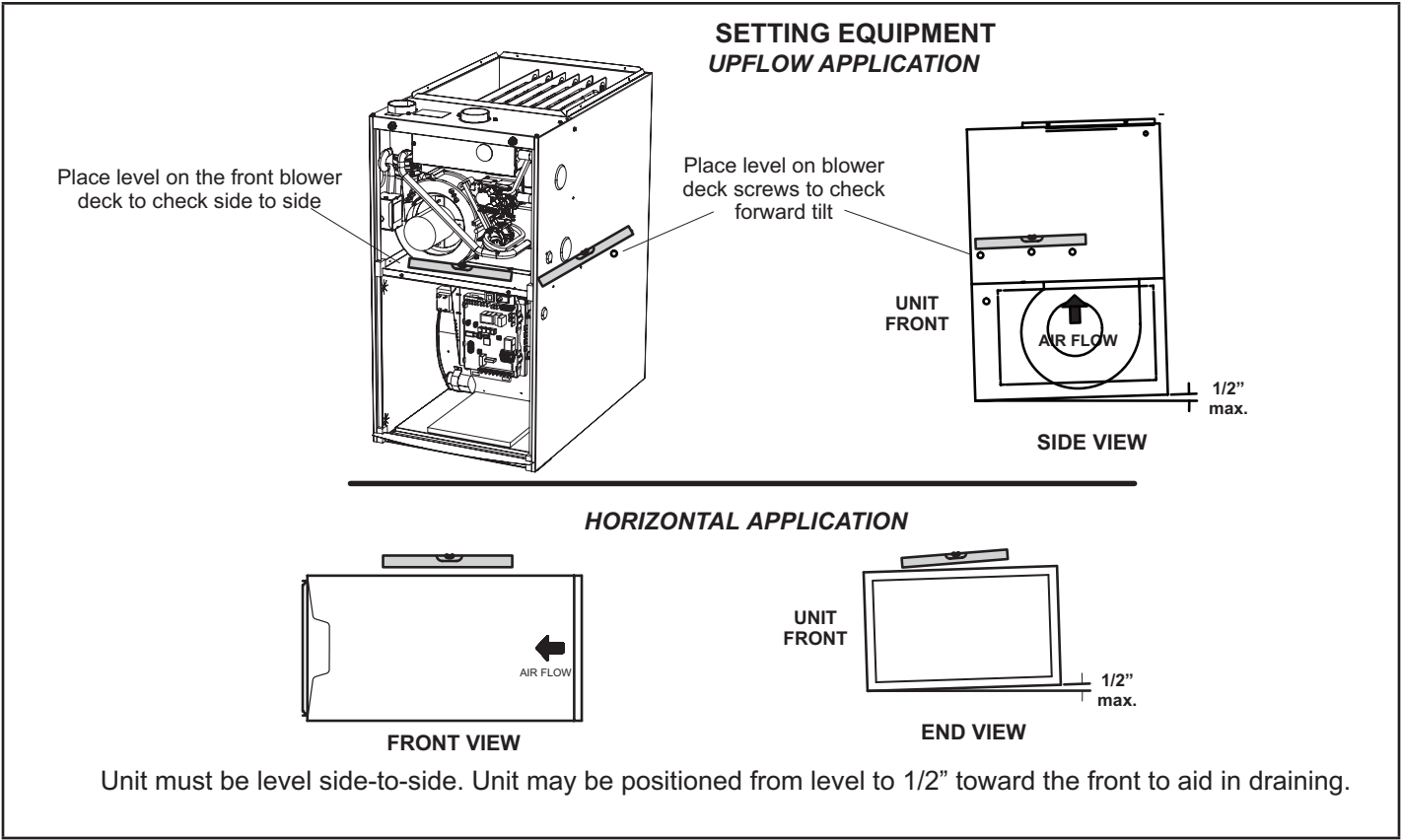
**⚠ WARNING**  
Blower access panel must be securely in place when blower and burners are operating. Gas fumes, which could contain carbon monoxide, can be drawn into living space resulting in personal injury or death.

**Upflow Applications**

The ML296UHV gas furnace can be installed as shipped in the upflow position. Refer to FIGURE 12 for clearances. Select a location that allows for the required clearances that are listed on the unit nameplate. Also consider gas supply connections, electrical supply, vent connection, condensate trap and drain connections, and installation and service clearances [24 inches (610 mm) at unit front]. **The unit must be level from side to side. The unit may be positioned from level to 1/2" toward the front. See FIGURE 11.**

Allow for clearances to combustible materials as indicated on the unit nameplate.



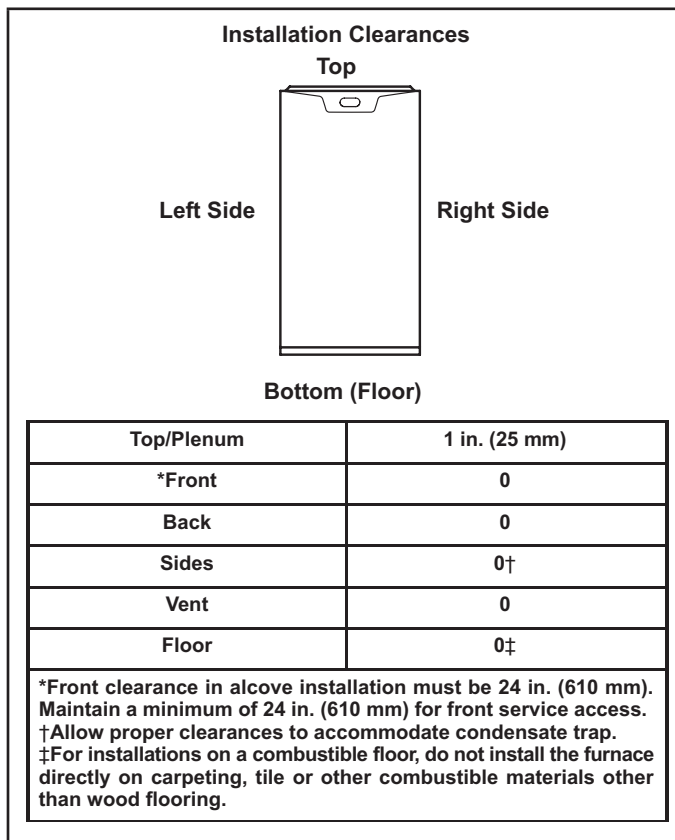


**FIGURE 11**

## ⚠ WARNING

Improper installation of the furnace can result in personal injury or death. Combustion and flue products must never be allowed to enter the return air system or air in the living space. Use sheet metal screws and joint tape to seal return air system to furnace. In platform installations with furnace return, the furnace should be sealed airtight to the return air plenum. A door must never be used as a portion of the return air duct system. The base must provide a stable support and an airtight seal to the furnace. Allow absolutely no sagging, cracks, gaps, etc.

For no reason should return and supply air duct systems ever be connected to or from other heating devices such as a fireplace or stove, etc. Fire, explosion, carbon monoxide poisoning, personal injury and/or property damage could result.



**FIGURE 12**

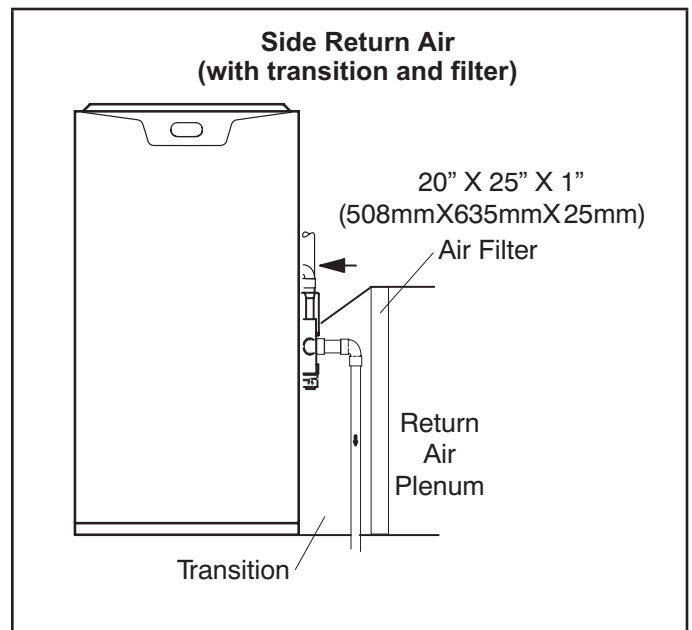
### Return Air Guidelines

Return air can be brought in through the bottom or either side of the furnace installed in an upflow application. If the furnace is installed on a platform with bottom return, make an airtight seal between the bottom of the furnace and the platform to ensure that the furnace operates properly and safely. The furnace is equipped with a removable bottom panel to facilitate installation.

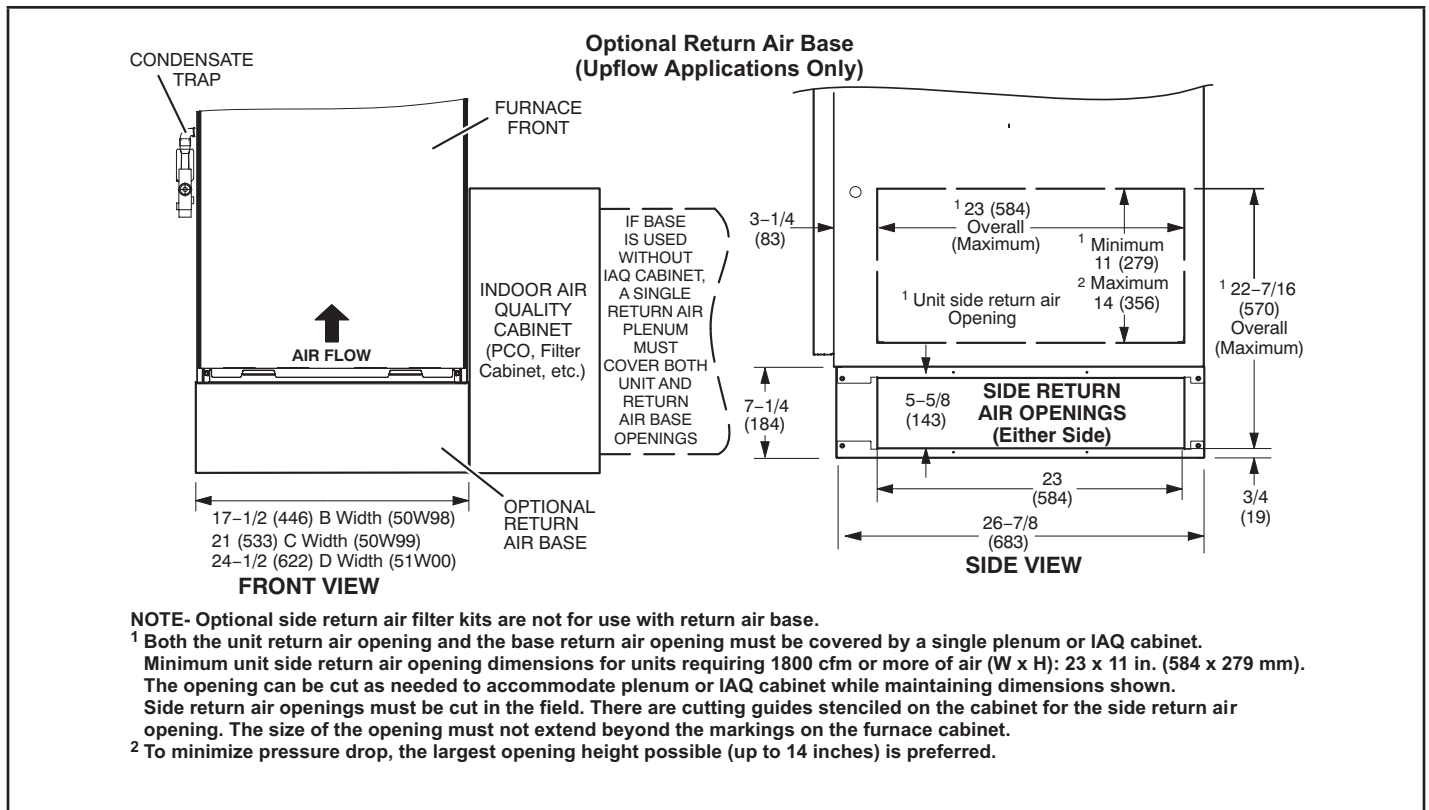
Markings are provided on both sides of the furnace cabinet for installations that require side return air. Cut the furnace cabinet at the maximum dimensions shown on page 2.

Refer to Engineering Handbook for additional information.

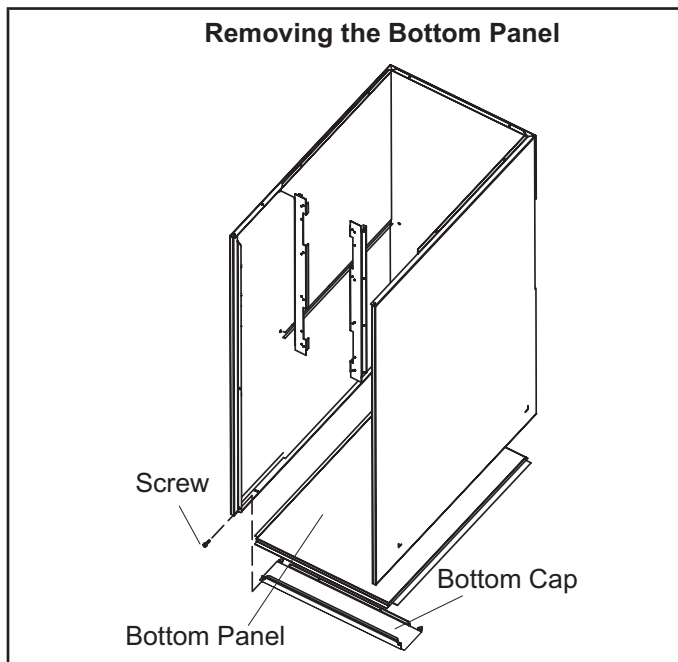
ML296UHV applications which include side return air and a condensate trap installed on the same side of the cabinet (trap can be installed remotely within 5 ft.) require either a return air base or field-fabricated transition to accommodate an optional IAQ accessory taller than 14.5". See FIGURE 13.



**FIGURE 13**



**FIGURE 14**



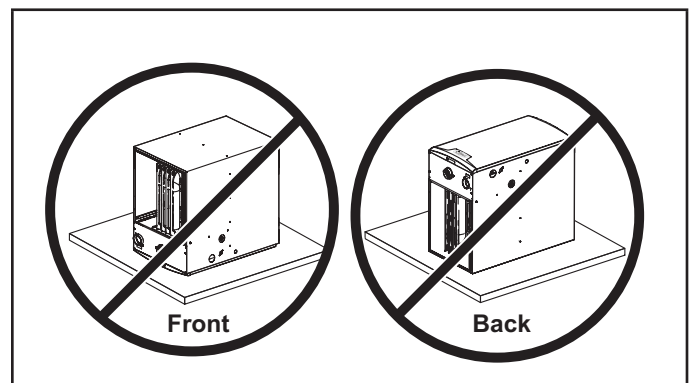
**FIGURE 15**

**Removing the Bottom Panel**

Remove the two screws that secure the bottom cap to the furnace. Pivot the bottom cap down to release the bottom panel. Once the bottom panel has been removed, reinstall the bottom cap. See FIGURE 15.

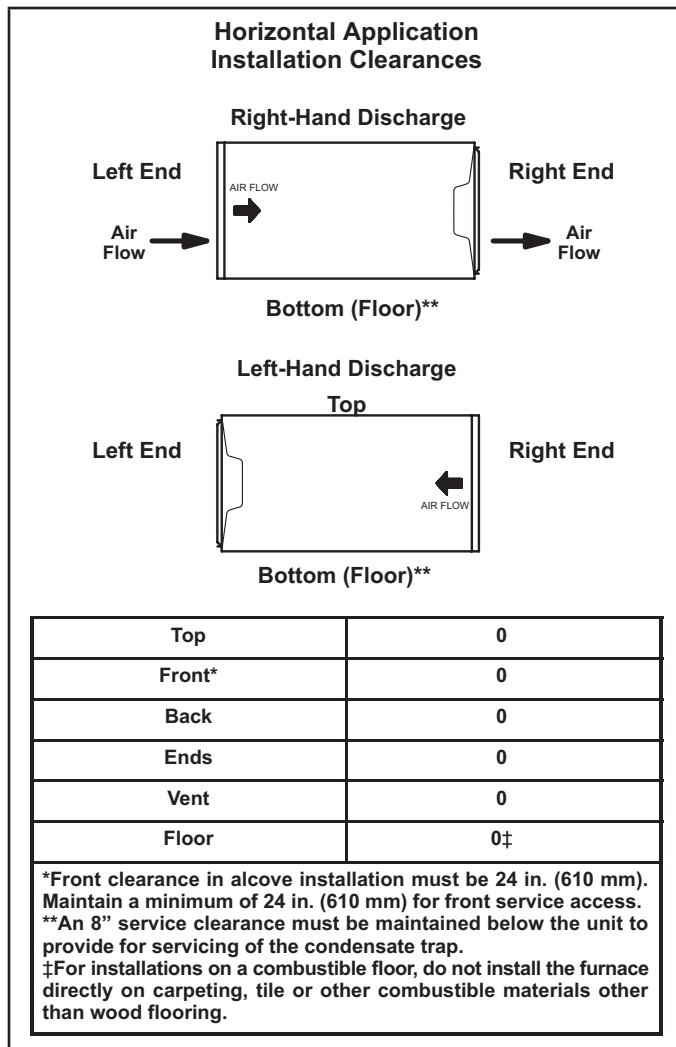
**⚠ WARNING**

Do not install the furnace on its front or back. See FIGURE 16.



**FIGURE 16**

The ML296UHV furnace can be installed in horizontal applications with either right- or left-hand air discharge. Refer to FIGURE 17 for clearances in horizontal applications.

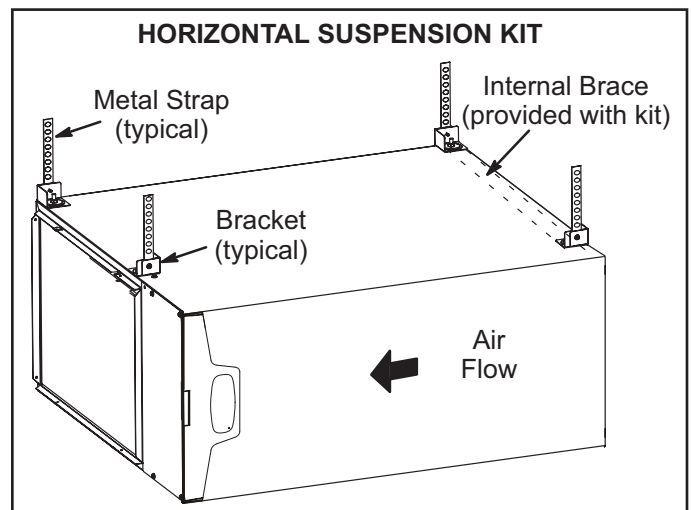


**FIGURE 17**

### Suspended Installation of Horizontal Unit

This furnace may be installed in either an attic or a crawlspace. Either suspend the furnace from roof rafters or floor joists, as shown in FIGURE 18, or install the furnace on a platform, as shown in FIGURE 19. A horizontal suspension kit (51W10) may be ordered from Lennox or use equivalent.

**NOTE** - Heavy-gauge sheet metal straps may be used to suspend the unit from roof rafters or ceiling joists. When straps are used to suspend the unit in this way, support must be provided for both the ends. The straps must not interfere with the plenum or exhaust piping installation. Cooling coils and supply and return air plenums must be supported separately.



**FIGURE 18**

**NOTE** - When the furnace is installed on a platform or with the horizontal suspension kit in a crawlspace, it must be elevated enough to avoid water damage, accommodate drain trap and to allow the evaporator coil to drain.

### Platform Installation of Horizontal Unit

- 1 - Select location for unit keeping in mind service and other necessary clearances. See FIGURE 17.
- 2 - Construct a raised wooden frame and cover frame with a plywood sheet. If unit is installed above finished space, install an auxiliary drain pan under unit. Set unit in drain pan as shown in FIGURE 19. Leave 8 inches for service clearance below unit for condensate trap.
- 3 - Provide a service platform in front of unit. When installing the unit in a crawl space, a proper support platform may be created using cement blocks.
- 4 - Route auxiliary drain line so that water draining from this outlet will be easily noticed by the homeowner.

5 - If necessary, run the condensate line into a condensate pump to meet drain line slope requirements. The pump must be rated for use with condensing furnaces. Protect the condensate discharge line from the pump to the outside to avoid freezing.

6 - Continue with exhaust, condensate and intake piping installation according to instructions.

### Return Air -- Horizontal Applications

Return air may be brought in only through the end of a furnace installed in the horizontal position. The furnace is equipped with a removable bottom panel to facilitate installation. See FIGURE 15.

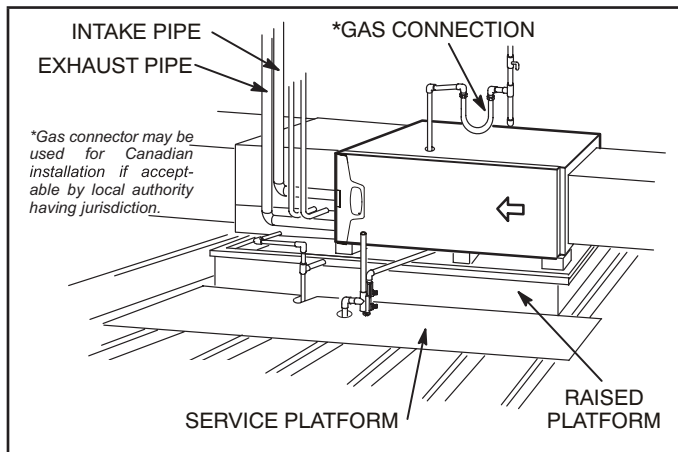


FIGURE 19

### Filters

This unit is not equipped with a filter or rack. A field-provided high velocity rated filter is required for the unit to operate properly. TABLE 1 lists recommended filter sizes. A filter must be in place whenever the unit is operating.

## ⚠ IMPORTANT

If a high efficiency filter is being installed as part of this system to ensure better indoor air quality, the filter must be properly sized. High efficiency filters have a higher static pressure drop than standard efficiency glass/foam filters. If the pressure drop is too great, system capacity and performance may be reduced.

The pressure drop may also cause the limit to trip more frequently during the winter and the indoor coil to freeze in the summer, resulting in an increase in the number of service calls.

Before using any filter with this system, check the specifications provided by the filter manufacturer against the data given in the appropriate Lennox Product Specifications bulletin. Additional information is provided in Service and Application Note ACC002 (August 2000).

TABLE 1

Furnace Cabinet Width	Filter Size	
	Side Return	Bottom Return
17-1/2"	16 X 25 X 1 (1)	16 X 25 X 1 (1)
21"	16 X 25 X 1 (1)	20 X 25 X 1 (1)
24-1/2"	16 X 25 X 1 (2)	24 X 25 X 1 (1)

### Duct System

Use industry-approved standards to size and install the supply and return air duct system. Refer to ACCA Manual D. This will result in a quiet and low-static system that has uniform air distribution. See below for proper duct installation.

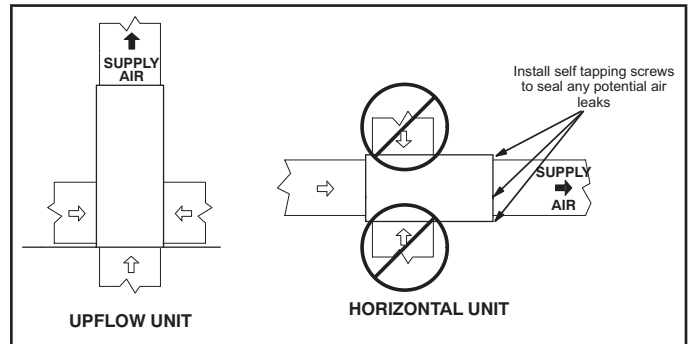


FIGURE 20

**NOTE -** This furnace is not certified for operation in heating mode (indoor blower operating at selected heating speed) with an external static pressure which exceeds 0.8 inches w.c. Operation at these conditions may result in improper limit operation.

### Supply Air Plenum

If the furnace is installed without a cooling coil, a removable access panel should be installed in the supply air duct. The access panel should be large enough to permit inspection of the heat exchanger. The furnace access panel must always be in place when the furnace is operating and it must not allow leaks. For horizontal only, install self tapping screws in the three evaporator coil screw holes made for horizontal applications to seal the top cap to the vestibule panel.

### Return Air Plenum

**NOTE - Return air must not be drawn from a room where this furnace, or any other gas-fueled appliance (i.e., water heater), or carbon monoxide-producing device (i.e., wood fireplace) is installed.**

When return air is drawn from a room, a negative pressure is created in the room. If a gas appliance is operating in a room with negative pressure, the flue products can be pulled back down the vent pipe and into the room. This reverse flow of the flue gas may result in incomplete combustion and the formation of carbon monoxide gas. This raw gas or toxic fumes might then be distributed throughout the house by the furnace duct system.

Return air can be brought in through the bottom or either side of the furnace (return air brought into either side of furnace allowed only in upflow applications). If a furnace with bottom return air is installed on a platform, make an airtight seal between the bottom of the furnace and the platform to ensure that the unit operates properly and safely. Use fiberglass sealing strips, caulking, or equivalent sealing method between the plenum and the furnace cabinet to ensure a tight seal. If a filter is installed, size the return air duct to fit the filter frame

**TABLE 2**

<b>PIPING AND FITTINGS SPECIFICATIONS</b>	
Schedule 40 PVC (Pipe)	D1785
Schedule 40 PVC (Cellular Core Pipe)	F891
Schedule 40 PVC (Fittings)	D2466
Schedule 40 CPVC (Pipe)	F441
Schedule 40 CPVC (Fittings)	F438
SDR-21 PVC or SDR-26 PVC (Pipe)	D2241
SDR-21 CPVC or SDR-26 CPVC (Pipe)	F442
Schedule 40 ABS Cellular Core DWV (Pipe)	F628
Schedule 40 ABS (Pipe)	D1527
Schedule 40 ABS (Fittings)	D2468
ABS-DWV (Drain Waste & Vent) (Pipe & Fittings)	D2661
PVC-DWV (Drain Waste & Vent) Pipe & Fittings)	D2665
<b>PRIMER &amp; SOLVENT CEMENT</b>	<b>ASTM SPECIFICATION</b>
PVC & CPVC Primer	F656
PVC Solvent Cement	D2564
CPVC Solvent Cement	F493
ABS Solvent Cement	D2235
PVC/CPVC/ABS All Purpose Cement For Fittings & Pipe of the same material	D2564, D2235, F493
ABS to PVC or CPVC Transition Solvent Cement	D3188
<b>CANADA PIPE &amp; FITTING &amp; SOLVENT CEMENT</b>	<b>MARKING</b>
PVC & CPVC Pipe and Fittings	ULCS636
PVC & CPVC Solvent Cement	
ABS to PVC or CPVC Transition Cement	
<b>POLYPROPYLENE VENTING SYSTEM</b>	
PolyPro® by Duravent	
InnoFlue® by Centrotherm	

**Pipe & Fittings Specifications**

All pipe, fittings, primer and solvent cement must conform with American National Standard Institute and the American Society for Testing and Materials (ANSI/ASTM) standards. The solvent shall be free flowing and contain no lumps, undissolved particles or any foreign matter that adversely affects the joint strength or chemical resistance of the cement. The cement shall show no gelation, stratification, or separation that cannot be removed by stirring. Refer to the TABLE 2 below for approved piping and fitting materials.

**⚠ CAUTION**  
 Solvent cements for plastic pipe are flammable liquids and should be kept away from all sources of ignition. Do not use excessive amounts of solvent cement when making joints. Good ventilation should be maintained to reduce fire hazard and to minimize breathing of solvent vapors. Avoid contact of cement with skin and eyes.

Low temperature solvent cement is recommended during cooler weather. Metal or plastic strapping may be used for vent pipe hangers. Uniformly apply a liberal coat of PVC primer for PVC or use a clean dry cloth for ABS to clean inside socket surface of fitting and male end of pipe to depth of fitting socket.

**Canadian Applications Only** - Pipe, fittings, primer and solvent cement used to vent (exhaust) this appliance must be certified to ULC S636 and supplied by a single manufacturer as part of an approved vent (exhaust) system. In addition, the first three feet of vent pipe from the furnace flue collar must be accessible for inspection.

**⚠ IMPORTANT**  
 ML296UHV exhaust and intake connections are made of PVC. Use PVC primer and solvent cement when using PVC vent pipe. When using ABS vent pipe, use transitional solvent cement to make connections to the PVC fittings in the unit.

Use PVC primer and solvent cement or ABS solvent cement meeting ASTM specifications, refer to TABLE 2. As an alternate, use all purpose cement, to bond ABS, PVC, or CPVC pipe when using fittings and pipe made of the same materials. Use transition solvent cement when bonding ABS to either PVC or CPVC.

**TABLE 3  
OUTDOOR TERMINATION USAGE\***

Input Size	Vent Pipe Dia. in.	STANDARD				CONCENTRIC		
		Flush Mount Kit	Wall Kit		Field Fabricated	1-1.2 inch	2 inch	3 inch
			2 inch	3 inch		71M80 (US) 44W92 (CA)	69M29 (US) 44W92 (CA)	60L46 (US) 44W93 (CA)
045	2	<sup>3</sup> YES	YES	<sup>1</sup> YES	<sup>5</sup> YES	<sup>2</sup> YES		
	2-1/2	<sup>3</sup> YES	YES	<sup>1</sup> YES	<sup>5</sup> YES	<sup>2</sup> YES		
	3	<sup>3</sup> YES	YES	<sup>1</sup> YES	<sup>5</sup> YES	<sup>2</sup> YES		
070	2	<sup>3</sup> YES	YES	<sup>1</sup> YES	<sup>5</sup> YES	<sup>2</sup> YES		
	2-1/2	<sup>3</sup> YES	YES	<sup>1</sup> YES	<sup>5</sup> YES	<sup>2</sup> YES		
	3	<sup>3</sup> YES	YES	<sup>1</sup> YES	<sup>5</sup> YES	<sup>2</sup> YES		
090	2	<sup>3</sup> YES		YES	<sup>5</sup> YES		YES	YES
	2-1/2	<sup>3</sup> YES		YES	<sup>5</sup> YES		YES	YES
	3	<sup>3</sup> YES		YES	<sup>5</sup> YES		YES	YES
110	2	YES		YES	<sup>5</sup> YES		YES	YES
	2-1/2	YES		YES	<sup>5</sup> YES		YES	YES
	3	YES		YES	<sup>5</sup> YES		YES	YES

NOTE - Standard Terminations do not include any vent pipe or elbows external to the structure. Any vent pipe or elbows external to the structure must be included in total vent length calculations. See vent length tables.

\* Kits must be properly installed according to kit instructions.

1 Requires field-provided outdoor 1-1/2" exhaust accelerator.

2 Concentric kits 71M80 and 44W92 include 1-1/2" outdoor accelerator, when used with 045 and 070 input models.

3 Flush mount kits 51W11 and 51W12 includes 1-1/2 in. outdoor exhaust accelerator, required when used with 045, 070 and 090 input models.

4 Termination kits 30G28, 44W92, 44W93 and 81J20 are certified to ULC S636 for use in Canada only.

5 See table 8 for vent accelerator requirements.

### Joint Cementing Procedure

All cementing of joints should be done according to the specifications outlined in ASTM D 2855.

## DANGER

### DANGER OF EXPLOSION!

Fumes from PVC glue may ignite during system check. Allow fumes to dissipate for at least 5 minutes before placing unit into operation..

- 1 - Measure and cut vent pipe to desired length.
- 2 - Deburr and chamfer end of pipe, removing any ridges or rough edges. If end is not chamfered, edge of pipe may remove cement from fitting socket and result in a leaking joint.  
**NOTE - Check the inside of vent pipe thoroughly for any obstruction that may alter furnace operation.**
- 3 - Clean and dry surfaces to be joined.
- 4 - Test fit joint and mark depth of fitting on outside of pipe.

- 5 - Uniformly apply a liberal coat of PVC primer for PVC or use a clean dry cloth for ABS to clean inside socket surface of fitting and male end of pipe to depth of fitting socket.

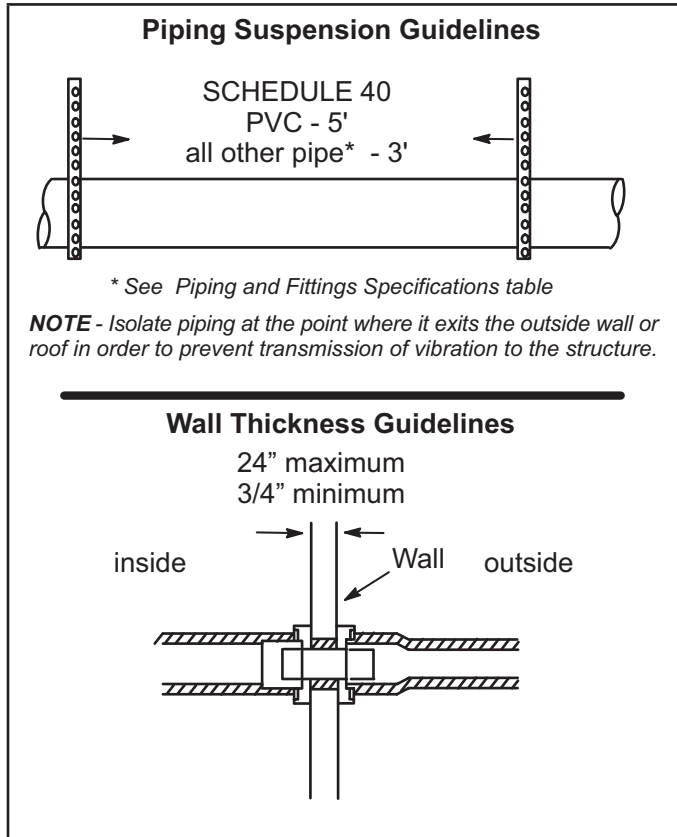
**NOTE - Time is critical at this stage. Do not allow primer to dry before applying cement.**

- 6 - Promptly apply solvent cement to end of pipe and inside socket surface of fitting. Cement should be applied lightly but uniformly to inside of socket. Take care to keep excess cement out of socket. Apply second coat to end of pipe.
- 7 - Immediately after applying last coat of cement to pipe, and while both inside socket surface and end of pipe are wet with cement, forcefully insert end of pipe into socket until it bottoms out. Turn PVC pipe 1/4 turn during assembly (but not after pipe is fully inserted) to distribute cement evenly. DO NOT turn ABS or cellular core pipe.

**NOTE - Assembly should be completed within 20 seconds after last application of cement. Hammer blows should not be used when inserting pipe.**

- 8 - After assembly, wipe excess cement from pipe at end of fitting socket. A properly made joint will show a bead around its entire perimeter. Any gaps may indicate an improper assembly due to insufficient solvent.
- 9 - Handle joints carefully until completely set.

**Venting Practices**



**FIGURE 21**

- 1 - In areas where piping penetrates joists or interior walls, hole must be large enough to allow clearance on all sides of pipe through center of hole using a hanger.
- 2 - When furnace is installed in a residence where unit is shut down for an extended period of time, such as a vacation home, make provisions for draining condensate collection trap and lines.

**Removal of the Furnace from Common Vent**

In the event that an existing furnace is removed from a venting system commonly run with separate gas appliances, the venting system is likely to be too large to properly vent the remaining attached appliances.

Conduct the following test while each appliance is operating and the other appliances (which are not operating) remain connected to the common venting system. If the venting system has been installed improperly, you must correct the system as indicated in the general venting requirements section.

**⚠ WARNING**

**CARBON MONOXIDE POISONING HAZARD**

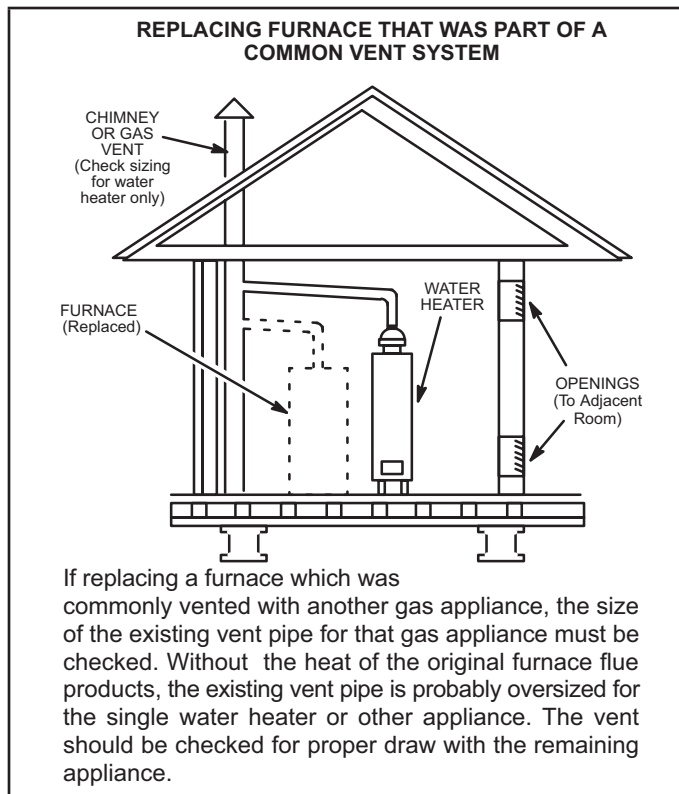
Failure to follow the steps outlined below for each appliance connected to the venting system being placed into operation could result in carbon monoxide poisoning or death.

The following steps shall be followed for each appliance connected to the venting system being placed into operation, while all other appliances connected to the venting system are not in operation:

- 1 - Seal any unused openings in the common venting system.
- 2 - Inspect the venting system for proper size and horizontal pitch. Determine that there is no blockage, restriction, leakage, corrosion, or other deficiencies which could cause an unsafe condition.
- 3 - Close all building doors and windows and all doors between the space in which the appliances remaining connected to the common venting system are located and other spaces of the building. Turn on clothes dryers and any appliances not connected to the common venting system. Turn on any exhaust fans, such as range hoods and bathroom exhausts, so they will operate at maximum speed. Do not operate a summer exhaust fan. Close fireplace dampers.
- 4 - Follow the lighting instructions. Turn on the appliance that is being inspected. Adjust the thermostat so that the appliance operates continuously.
- 5 - After the main burner has operated for 5 minutes, test for leaks of flue gases at the draft hood relief opening. Use the flame of a match or candle.
- 6 - After determining that each appliance connected to the common venting system is venting properly, (step 3) return all doors, windows, exhaust fans, fireplace dampers, and any other gas-burning appliances to their previous mode of operation.
- 7 - If a venting problem is found during any of the preceding tests, the common venting system must be modified to correct the problem.



Resize the common venting system to the minimum vent pipe size determined by using the appropriate tables in Appendix G. (These are in the current standards of the National Fuel Gas Code ANSI Z223.1.



**FIGURE 22**

**Exhaust Piping (FIGURE 23, FIGURE 25 and FIGURE 26)**

Route piping to outside of structure. Continue with installation following instructions given in piping termination section

**⚠ CAUTION**

Do not discharge exhaust into an existing stack or stack that also serves another gas appliance. If vertical discharge through an existing unused stack is required, insert PVC pipe inside the stack until the end is even with the top or outlet end of the metal stack.

**⚠ CAUTION**

The exhaust vent pipe operates under positive pressure and must be completely sealed to prevent leakage of combustion products into the living space.

**Vent Piping Guidelines**

**NOTE** - Lennox has approved the use of DuraVent® and Centrotherm manufactured vent pipe and terminations as an option to PVC. When using the PolyPro® by DuraVent or InnoFlue® by Centrotherm venting system the vent pipe requirements stated in the unit installation instruction – minimum & maximum vent lengths, termination clearances, etc. – apply and must be followed. Follow the instructions provided with PolyPro by DuraVent and InnoFlue by Centrotherm venting system for assembly or if requirements are more restrictive. The PolyPro by DuraVent and InnoFlue by Centrotherm venting system must also follow the uninsulated and unconditioned space criteria listed in TABLE 7.

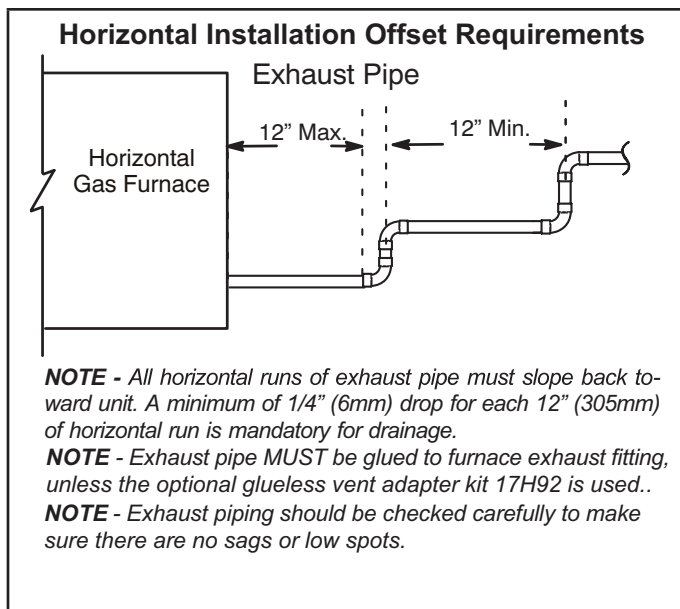
**The ML296UHV can be installed as either a Non-Direct Vent or a Direct Vent gas central furnace.**

**NOTE** - In Non-Direct Vent installations, combustion air is taken from indoors or ventilated attic or crawlspace and flue gases are discharged outdoors. In Direct Vent installations, combustion air is taken from outdoors and flue gases are discharged outdoors.

**Intake and exhaust pipe sizing** -- Size pipe according to TABLE 4 (minimum) and TABLE 5 (maximum). Count all elbows inside and outside the home. Regardless of the diameter of pipe used, the standard roof and wall terminations described in section *Exhaust Piping Terminations* should be used. Exhaust vent termination pipe is sized to optimize the velocity of the exhaust gas as it exits the termination. Refer to TABLE 8.

In some applications which permit the use of several different sizes of vent pipe, a combination vent pipe may be used. Contact Lennox' Application Department for assistance in sizing vent pipe in these applications.

**NOTE** - The exhaust collar on all models is sized to accommodate 2" Schedule 40 vent pipe. In horizontal applications, any transition to exhaust pipe larger than 2" must be made in vertical runs of the pipe. Therefore a 2" elbow must be added before the pipe is transitioned to any size larger than 2". This elbow must be added to the elbow count used to determine acceptable vent lengths. Contact the Application Department for more information concerning sizing of vent systems which include multiple pipe sizes.



**FIGURE 23**

**NOTE** - Lennox offers a glueless vent adapter kit 17H92 as an option for exhaust exiting at the furnace top cap coupling. If the kit is not used the exhaust pipe **MUST** be glued to furnace exhaust fitting.

**TABLE 4**

**MINIMUM VENT PIPE LENGTHS**

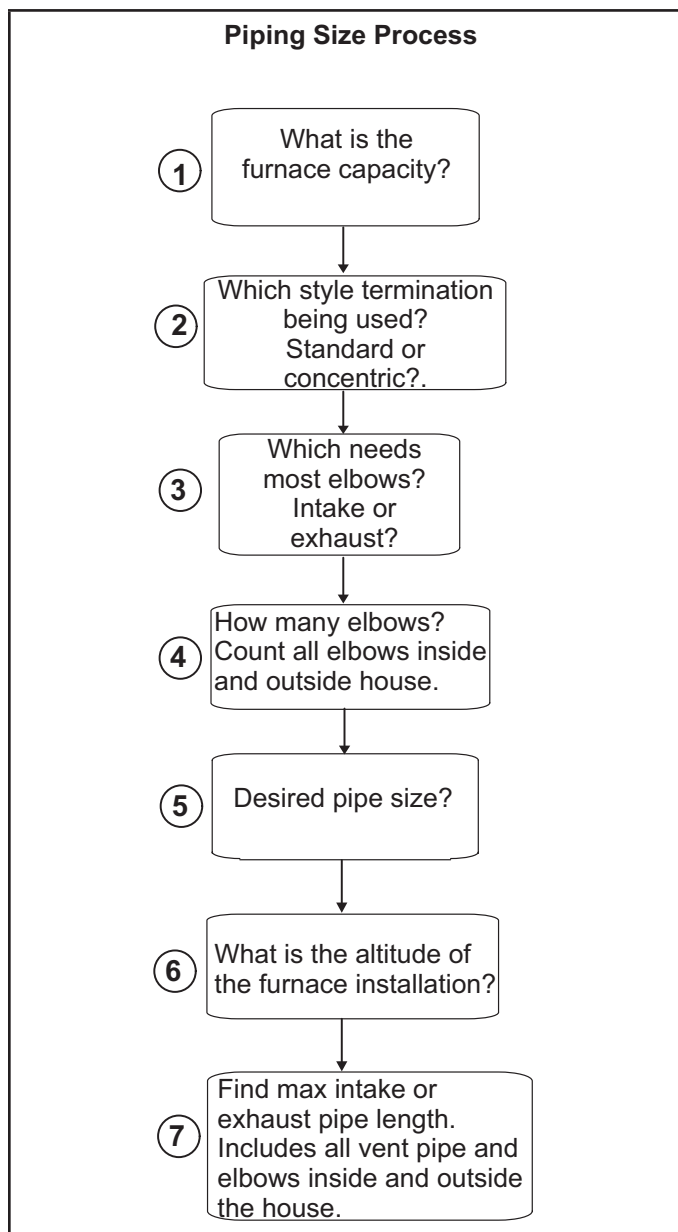
ML296UHV MODEL	MIN. VENT LENGTH*
045, 070, 090, 110	15 ft. or 5 ft plus 2 elbows or 10 ft plus 1 elbow

\*Any approved termination may be added to the minimum length listed. Two 45 degree elbows are the equivalent to one 90 degree elbow.

⚠ **IMPORTANT**

Do not use screens or perforated metal in exhaust or intake terminations. Doing so will cause freeze-ups and may block the terminations.

Use the following steps to correctly size vent pipe diameter.



**FIGURE 24**

**TABLE 5**

**Maximum Allowable Intake or Exhaust Vent Length in Feet**

NOTE - Size intake and exhaust pipe length separately. Values in table are for Intake OR Exhaust, not combined total. Both Intake and Exhaust must be same pipe size.

Standard Termination at Elevation 0 - 4500 ft													
Number Of 90° Elbows Used	2" Pipe				2-1/2" Pipe				3" Pipe				
	Model				Model				Model				
	045	070	090	110	045	070	090	110	045	070	090	110	
1	81	66	44	22	115	115	93	58	138	137	118	118	
2	76	61	39	19	110	110	88	53	133	132	113	113	
3	71	56	34	14	105	105	83	48	128	127	108	108	
4	66	51	29	n/a	100	100	78	43	123	122	103	103	
5	61	46	24		95	95	73	38	118	117	98	98	
6	56	41	19		90	90	68	33	113	112	93	93	
7	51	36	14		85	85	63	28	108	107	88	88	
8	46	31	n/a		80	80	58	23	103	102	83	83	
9	41	26			75	75	53	18	98	97	78	78	
10	36	21			70	70	48	13	93	92	73	73	
Standard Termination Elevation 4500 - 10,000 ft													
Number Of 90° Elbows Used	2" Pipe				2-1/2" Pipe				3" Pipe				
	Model				Model				Model				
	045	070	090	110	045	070	090	110	045	070	090	110	
1	81	66	44	n/a	115	115	93	58	138	137	118	118	
2	76	61	39		110	110	88	53	133	132	113	113	
3	71	56	34		105	105	83	48	128	127	108	108	
4	66	51	29		100	100	78	43	123	122	103	103	
5	61	46	24		95	96	73	38	118	117	98	98	
6	56	41	19		90	90	68	33	113	112	93	93	
7	51	36	14		85	85	63	28	108	107	88	88	
8	46	31	n/a		80	80	58	23	103	102	83	83	
9	41	26			75	75	53	18	98	97	78	78	
10	36	21			70	70	48	13	93	92	73	73	

See concentric terminations next page.

**TABLE 5 Continued**

**Maximum Allowable Intake or Exhaust Vent Length in Feet**

*NOTE - Size intake and exhaust pipe length separately. Values in table are for Intake OR Exhaust, not combined total. Both Intake and Exhaust must be same pipe size.*

<b>Concentric Termination at Elevation 0 - 4500 ft</b>													
<b>Number Of 90° Elbows Used</b>	<b>2" Pipe</b>				<b>2-1/2" Pipe</b>				<b>3" Pipe</b>				
	<b>Model</b>				<b>Model</b>				<b>Model</b>				
	<b>045</b>	<b>070</b>	<b>090</b>	<b>110</b>	<b>045</b>	<b>070</b>	<b>090</b>	<b>110</b>	<b>045</b>	<b>070</b>	<b>090</b>	<b>110</b>	
1	73	58	42	22	105	105	89	54	121	121	114	114	
2	68	53	37	17	100	100	84	49	116	116	109	109	
3	63	48	32	12	95	95	79	44	111	111	104	104	
4	58	43	27	n/a	90	90	74	39	106	106	99	99	
5	53	38	22		85	85	69	34	101	101	94	94	
6	48	33	17		80	80	64	29	96	96	89	89	
7	43	28	12		75	75	59	24	91	91	84	84	
8	38	23	n/a		70	70	54	19	86	86	79	79	
9	33	18			65	65	49	14	81	81	74	74	
10	28	13			60	60	44	n/a	76	76	69	69	
<b>Concentric Termination Elevation 4500 - 10,000 ft</b>													
<b>Number Of 90° Elbows Used</b>	<b>2" Pipe</b>				<b>2-1/2" Pipe</b>				<b>3" Pipe</b>				
	<b>Model</b>				<b>Model</b>				<b>Model</b>				
	<b>045</b>	<b>070</b>	<b>090</b>	<b>110</b>	<b>045</b>	<b>070</b>	<b>090</b>	<b>110</b>	<b>045</b>	<b>070</b>	<b>090</b>	<b>110</b>	
1	73	58	42	n/a	105	105	89	54	121	121	114	114	
2	68	53	37		100	100	84	49	116	116	109	109	
3	63	48	32		95	95	79	44	111	111	104	104	
4	58	43	27		90	90	74	39	106	106	99	99	
5	53	38	22		85	85	69	34	101	101	94	94	
6	48	33	17		80	80	64	29	96	96	89	89	
7	43	28	12		75	75	59	24	91	91	84	84	
8	38	23	n/a		70	70	54	19	86	86	79	79	
9	33	18			65	65	49	14	81	81	74	74	
10	28	13			60	60	44	n/a	76	76	69	69	

**TABLE 6**

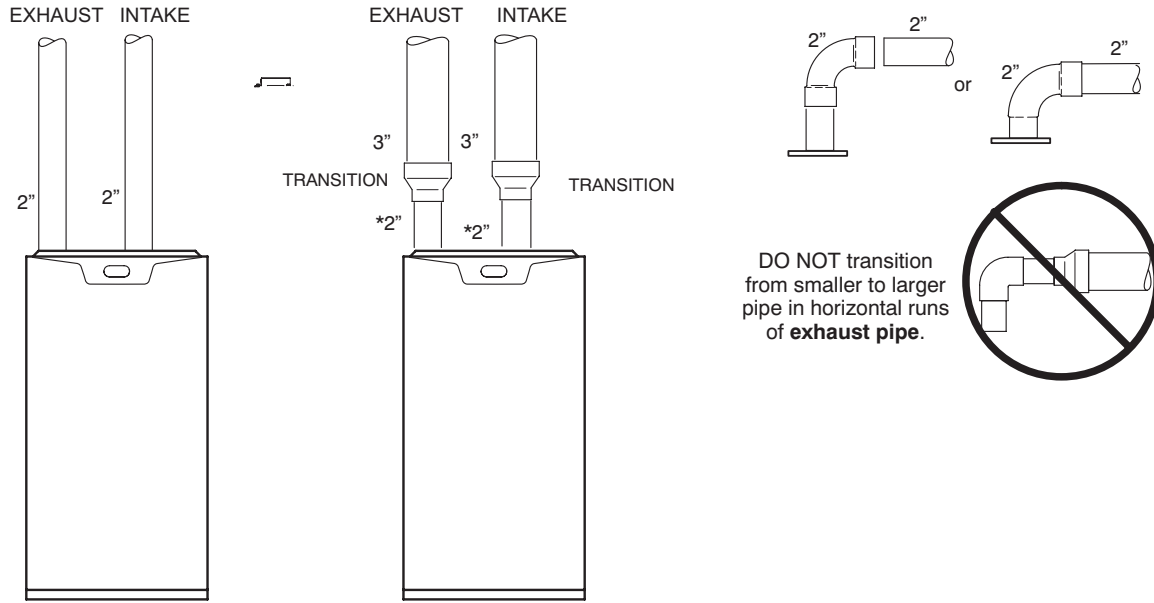
**Maximum Allowable Exhaust Vent Lengths With Furnace Installed in a Closet or Basement Using Ventilated Attic or Crawl Space For Intake Air in Feet**

*NOTE - Size intake and exhaust pipe length separately. Values in table are for Intake OR Exhaust, not combined total. Both Intake and Exhaust must be same pipe size.*

*NOTE - Additional vent pipe and elbows used to terminate the vent pipe outside the structure must be included in the total vent length calculation*

Standard Termination at Elevation 0 - 4500 ft													
Number Of 90° Elbows Used	2" Pipe				2-1/2" Pipe				3" Pipe				
	Model				Model				Model				
	045	070	090	110	045	070	090	110	045	070	090	110	
1	71	56	34	14	100	100	78	43	118	117	98	98	
2	66	51	29	9	95	95	73	38	113	112	93	93	
3	61	46	24	4	90	90	68	33	108	107	88	88	
4	56	41	19	n/a	85	85	63	28	103	102	83	83	
5	51	36	14		80	80	58	23	98	97	78	78	
6	46	31	9		75	75	53	18	93	92	73	73	
7	41	26	4		70	70	48	13	88	87	68	68	
8	36	21	n/a		65	65	43	8	83	82	63	63	
9	31	16			60	60	38	3	78	77	58	58	
10	26	11			55	55	33	n/a	73	72	53	53	
Standard Termination Elevation 4500 - 10,000 ft													
Number Of 90° Elbows Used	2" Pipe				2-1/2" Pipe				3" Pipe				
	Model				Model				Model				
	045	070	090	110	045	070	090	110	045	070	090	110	
1	71	56	34	n/a	100	100	78	43	118	117	98	98	
2	66	51	29		95	95	73	38	113	112	93	93	
3	61	46	24		90	90	68	33	108	107	88	88	
4	56	41	19		85	85	63	28	103	102	83	83	
5	51	36	14		80	80	58	23	98	97	78	78	
6	46	31	9		75	75	53	18	93	92	73	73	
7	41	26	4		70	70	48	13	88	87	68	68	
8	36	21	n/a		65	65	43	8	83	82	63	63	
9	31	16			60	60	38	3	78	77	58	58	
10	26	11			55	55	33	n/a	73	72	53	53	

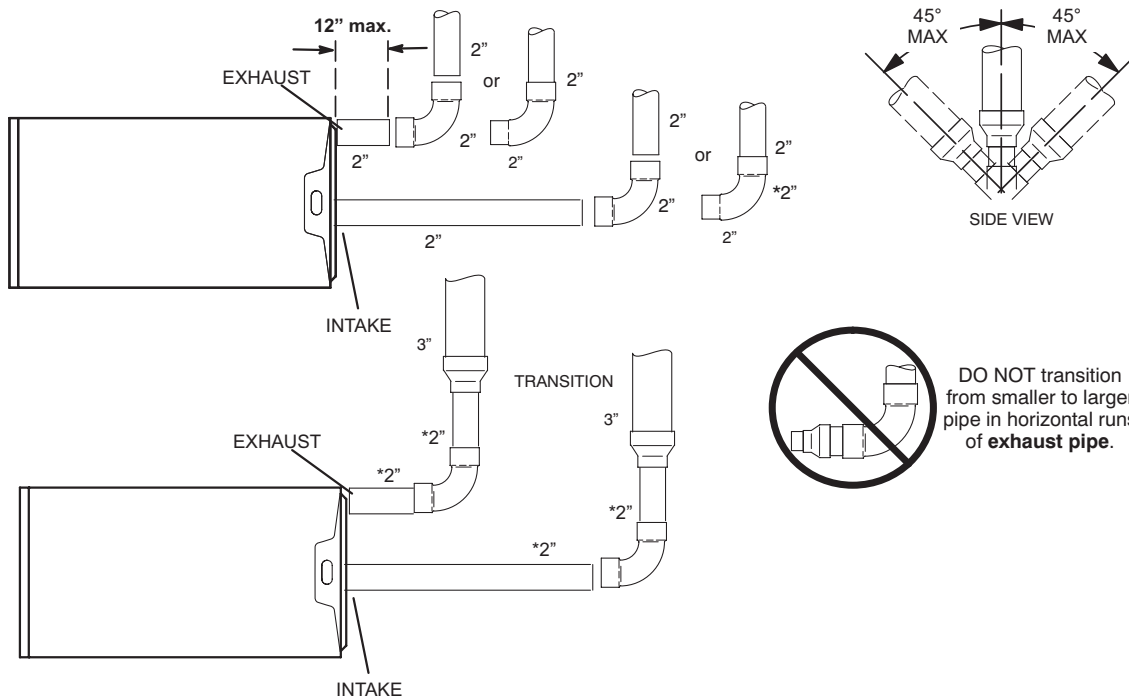
**TYPICAL EXHAUST AND INTAKE PIPE CONNECTIONS IN UPFLOW DIRECT OR NON-DIRECT VENT APPLICATIONS**



\* When transitioning up in pipe size, use the shortest length of 2" PVC pipe possible.

**FIGURE 25**

**TYPICAL EXHAUST AND INTAKE PIPE CONNECTIONS IN HORIZONTAL DIRECT OR NON-DIRECT VENT APPLICATIONS (RIGHT HAND DISCHARGE SHOWN)**



\* When transitioning up in pipe size, use the shortest length of 2" PVC pipe possible.

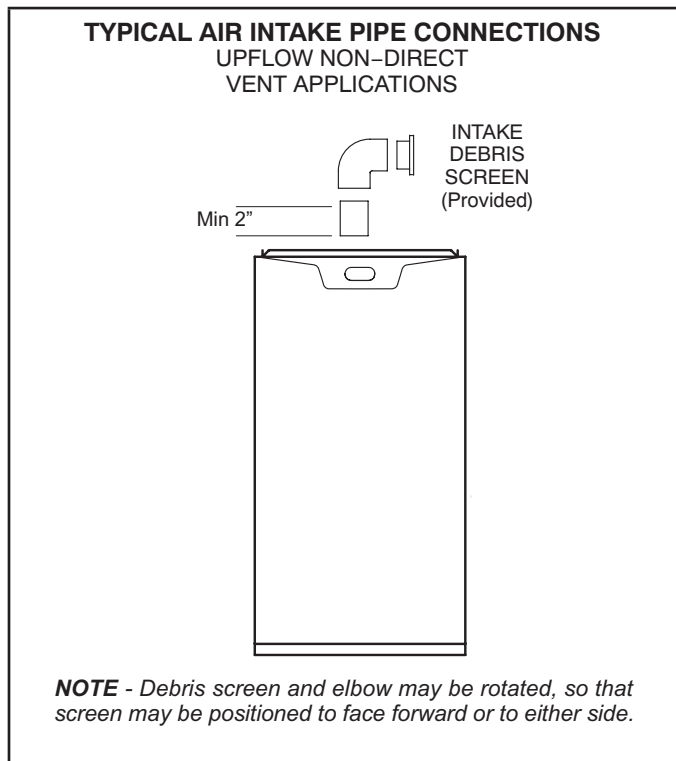
**FIGURE 26**

## Intake Piping

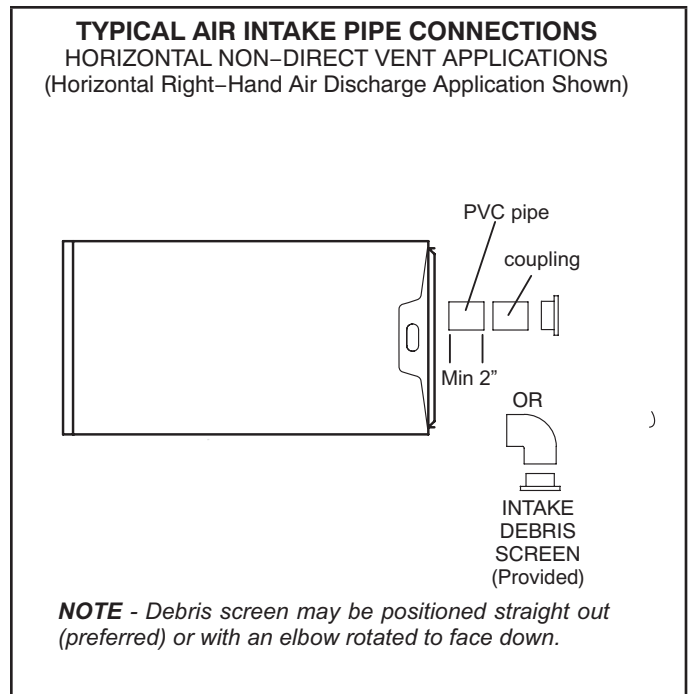
The ML296UHV furnace may be installed in either direct vent or non-direct vent applications. In non-direct vent applications, when intake air will be drawn into the furnace from the surrounding space, the indoor air quality must be considered and guidelines listed in Combustion, Dilution and Ventilation Air section must be followed.

Follow the next two steps when installing the unit in Direct Vent applications, where combustion air is taken from outdoors and flue gases are discharged outdoors. The provided air intake screen must not be used in direct vent applications (outdoors).

- 1 - Use transition solvent cement or a sheet metal screw to secure the intake pipe to the inlet air connector.
- 2 - Route piping to outside of structure. Continue with installation following instructions given in general guidelines for piping terminations and intake and exhaust piping terminations for direct vent sections. Refer to TABLE 5 for pipe sizes.



**FIGURE 27**



**FIGURE 28**

Follow the next two steps when installing the unit in **Non-Direct Vent applications** where combustion air is taken from indoors or ventilated attic or crawlspace and flue gases are discharged outdoors.

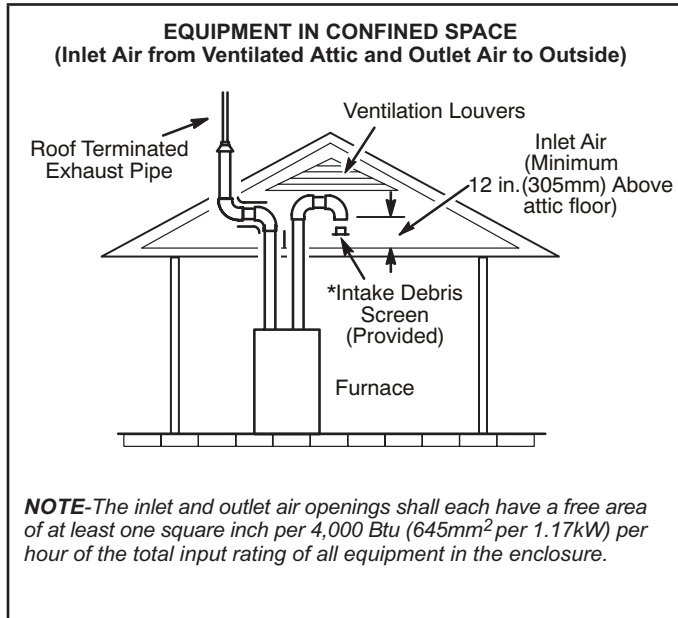
- 1 - Use field-provided materials and the factory-provided air intake screen to route the intake piping as shown in FIGURE 27 or FIGURE 28. Maintain a minimum clearance of 3" (76mm) around the air intake opening. The air intake opening (with the protective screen) should always be directed forward or to either side in the upflow position, and either straight out or downward in the horizontal position.

**The air intake piping must not terminate too close to the flooring or a platform. Ensure that the intake air inlet will not be obstructed by loose insulation or other items that may clog the debris screen.**

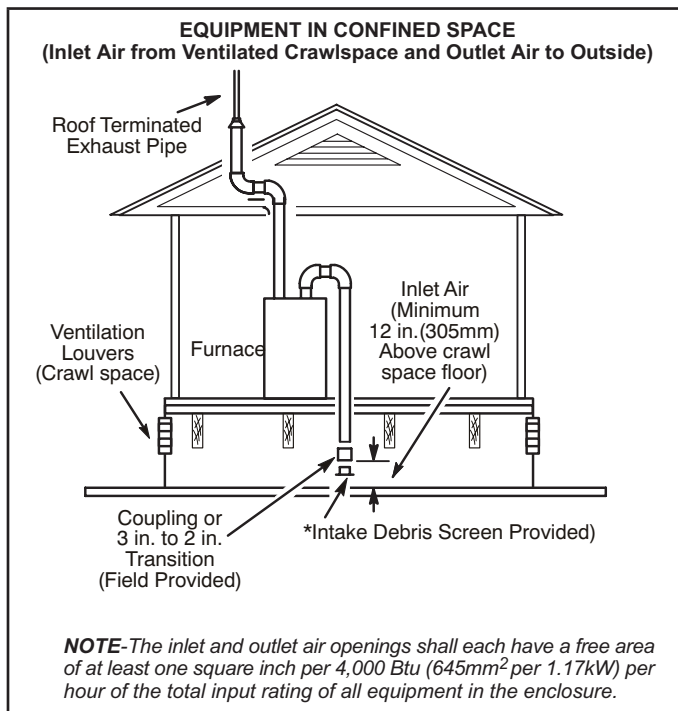
- 2 - If intake air is drawn from a ventilated attic (FIGURE 29) or ventilated crawlspace (FIGURE 30) the exhaust vent length must not exceed those listed in TABLE 6. If 3" diameter pipe is used, reduce to 2" diameter pipe at the termination point to accommodate the debris screen.
- 3 - Use a sheet metal screw to secure the intake pipe to the connector, if desired.

## ⚠ CAUTION

If this unit is being installed in an application with combustion air coming in from a space serviced by an exhaust fan, power exhaust fan, or other device which may create a negative pressure in the space, take care when sizing the inlet air opening. The inlet air opening must be sized to accommodate the maximum volume of exhausted air as well as the maximum volume of combustion air required for all gas appliances serviced by this space.



**FIGURE 29**



**FIGURE 30**

## General Guidelines for Vent Terminations

In Non-Direct Vent applications, combustion air is taken from indoors or ventilated attic or crawlspace and the flue gases are discharged to the outdoors. The ML296UHV is then classified as a non-direct vent, Category IV gas furnace.

In Direct Vent applications, combustion air is taken from outdoors and the flue gases are discharged to the outdoors.

The ML296UHV is then classified as a direct vent, Category IV gas furnace. In both Non-Direct Vent and Direct Vent applications, the vent termination is limited by local building codes. In the absence of local codes, refer to the current National Fuel Gas Code ANSI Z223-1/NFPA 54 in U.S.A., and current CSA-B149 Natural Gas and Propane Installation Codes in Canada for details.

Position termination according to location given in FIGURE 32 or FIGURE 33. In addition, position termination so it is free from any obstructions and 12" above the average snow accumulation.

At vent termination, care must be taken to maintain protective coatings over building materials (prolonged exposure to exhaust condensate can destroy protective coatings). It is recommended that the exhaust outlet not be located within 6 feet (1.8m) of an outdoor AC unit because the condensate can damage the painted coating.

**NOTE** - See TABLE 7 for maximum allowed exhaust pipe length without insulation in unconditioned space during winter design temperatures below 32°F (0°C). If required exhaust pipe should be insulated with 1/2" (13mm) Armaflex or equivalent. In extreme cold climate areas, 3/4" (19mm) Armaflex or equivalent may be necessary. Insulation must be protected from deterioration. Armaflex with UV protection is permissible. Basements or other enclosed areas that are not exposed to the outdoor ambient temperature and are above 32 degrees F (0°C) are to be considered conditioned spaces.

## ⚠ IMPORTANT

Do not use screens or perforated metal in exhaust or intake terminations. Doing so will cause freeze-ups and may block the terminations.

## ⚠ IMPORTANT

For Canadian Installations Only:  
In accordance to CSA International B149 installation codes, the minimum allowed distance between the combustion air intake inlet and the exhaust outlet of other appliances shall not be less than 12 inches (305mm).



**TABLE 7**

**Maximum Allowable Exhaust Vent Pipe Length (in ft.) Without Insulation In Unconditioned Space For Winter Design Temperatures Two - Stage High Efficiency Furnace**

Winter Design Temperatures <sup>1</sup> °F (°C)	Vent Pipe Diameter	Unit Input Size							
		045		070		090		110	
		PVC	<sup>2</sup> PP	PVC	<sup>2</sup> PP	PVC	<sup>2</sup> PP	PVC	<sup>2</sup> PP
32 to 21 (0 to -6)	2 in	21	18	33	30	46	42	30	30
	2-1/2 in	16	n/a	26	n/a	37	n/a	36	n/a
	3 in	12	12	21	21	30	30	29	29
20 to 1 (-7 to -17)	2 in	11	9	19	17	28	25	27	24
	2-1/2 in	7	n/a	14	n/a	21	n/a	20	n/a
	3 in	2	2	9	9	16	16	14	14
0 to -20 (-18 to -29)	2 in	6	4	12	10	19	16	18	15
	2-1/2 in	1	n/a	7	n/a	13	n/a	12	n/a
	3 in	1	1	2	2	8	8	7	7

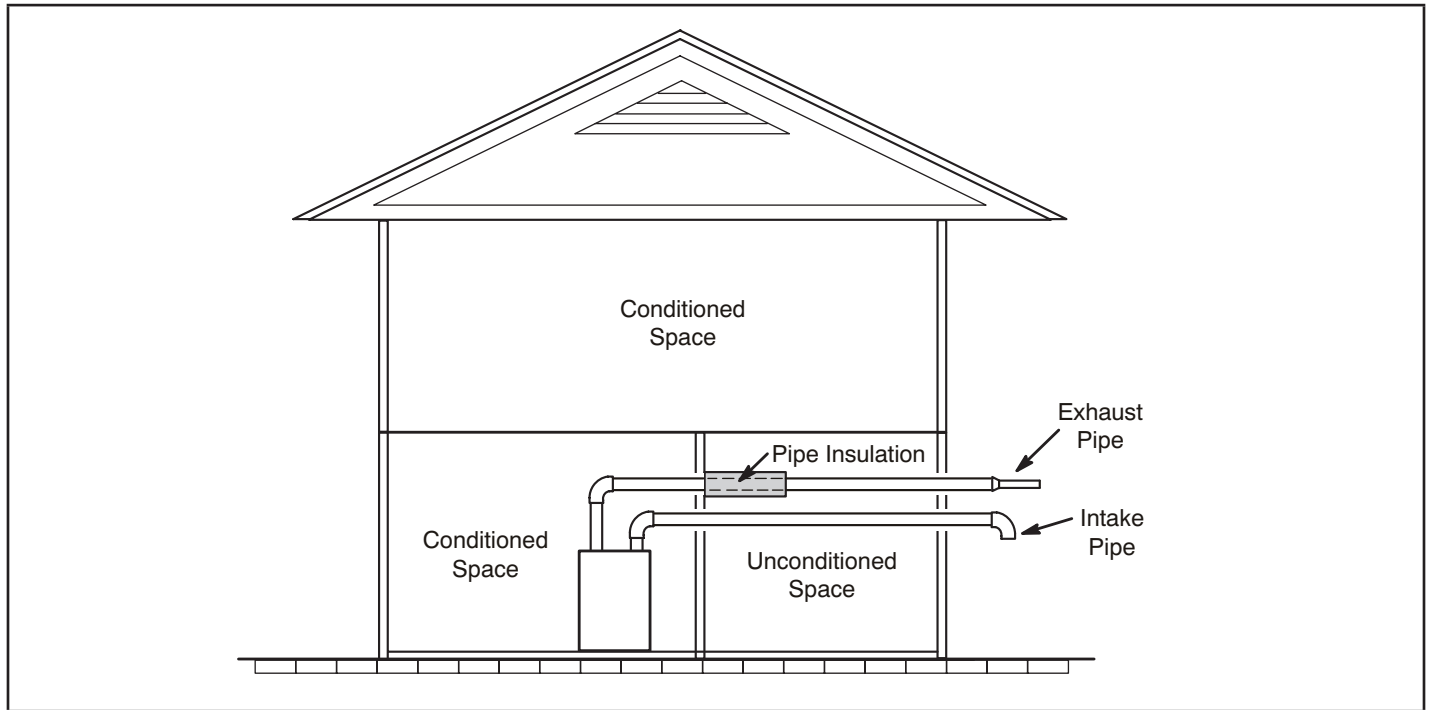
<sup>1</sup>Refer to 99% Minimum Design Temperature table provided in the current edition of the ASHRAE Fundamentals Handbook.

<sup>2</sup> Poly-Propylene vent pipe (PP) by Duravent and Centrotherm.

NOTE - Concentric terminations are the equivalent of 5' and should be considered when measuring pipe length.

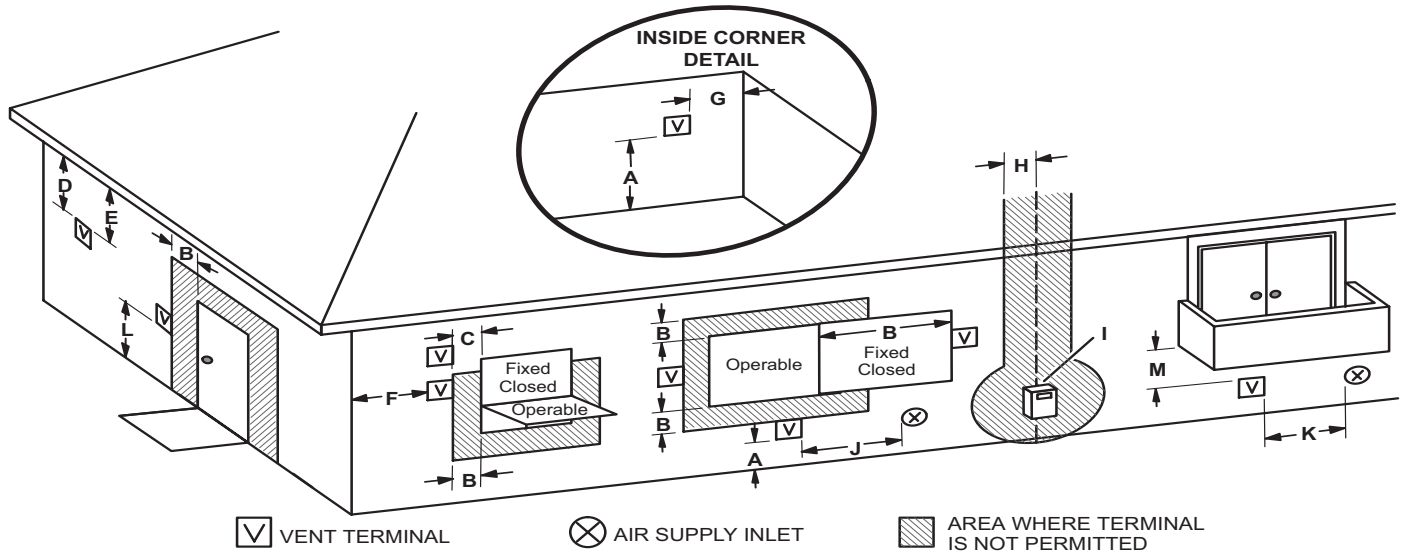
NOTE - Maximum uninsulated vent lengths listed may include the termination (vent pipe exterior to the structure) and cannot exceed 5 linear feet or the maximum allowable intake or exhaust vent length listed in table 5 or 6 which ever is less.

NOTE - If insulation is required in an unconditioned space, it must be located on the pipe closest to the furnace. See FIGURE 31.



**FIGURE 31**

## VENT TERMINATION CLEARANCES FOR NON-DIRECT VENT INSTALLATIONS IN THE US AND CANADA



	US Installations <sup>1</sup>	Canadian Installations <sup>2</sup>	
A =	Clearance above grade, veranda, porch, deck or balcony	12 inches (305mm) or 12 in. (305mm) above average snow accumulation.	12 inches (305mm) or 12 in. (305mm) above average snow accumulation.
B =	Clearance to window or door that may be opened	4 feet (1.2 m) below or to side of opening; 1 foot (30cm) above opening	6 inches (152mm) for appliances <10,000 Btuh (3kw), 12 inches (305mm) for appliances > 10,000 Btuh (3kw) and <100,000 Btuh (30kw), 36 inches (.9m) for appliances > 100,000 Btuh (30kw)
C =	Clearance to permanently closed window	* 12"	* 12"
D =	Vertical clearance to ventilated soffit located above the terminal within a horizontal distance of 2 feet (610 mm) from the center line of the terminal	* Equal to or greater than soffit depth.	* Equal to or greater than soffit depth.
E =	Clearance to unventilated soffit	* Equal to or greater than soffit depth.	* Equal to or greater than soffit depth.
F =	Clearance to outside corner	* No minimum to outside corner	* No minimum to outside corner
G =	Clearance to inside corner	*	*
H =	Clearance to each side of center line extended above meter / regulator assembly	* 3 feet (.9m) within a height 15 feet (4.5m) above the meter / regulator assembly	3 feet (.9m) within a height 15 feet (4.5m) above the meter / regulator assembly
I =	Clearance to service regulator vent outlet	* 3 feet (.9m)	3 feet (.9m)
J =	Clearance to non-mechanical air supply inlet to building or the combustion air inlet to any other appliance	4 feet (1.2 m) below or to side of opening; 1 foot (30 cm) above opening	6 inches (152mm) for appliances <10,000 Btuh (3kw), 12 inches (305mm) for appliances > 10,000 Btuh (3kw) and <100,000 Btuh (30kw), 36 inches (.9m) for appliances > 100,000 Btuh (30kw)
K =	Clearance to mechanical air supply inlet	3 feet (.9m) above if within 10 feet (3m) horizontally	6 feet (1.8m)
L =	Clearance above paved sidewalk or paved driveway located on public property	7 feet (2.1m)†	7 feet (2.1m)†
M =	Clearance under veranda, porch, deck or balcony	*12 inches (305mm)‡	12 inches (305mm)‡

<sup>1</sup> In accordance with the current ANSI Z223.1/NFPA 54 Natural Fuel Gas Code

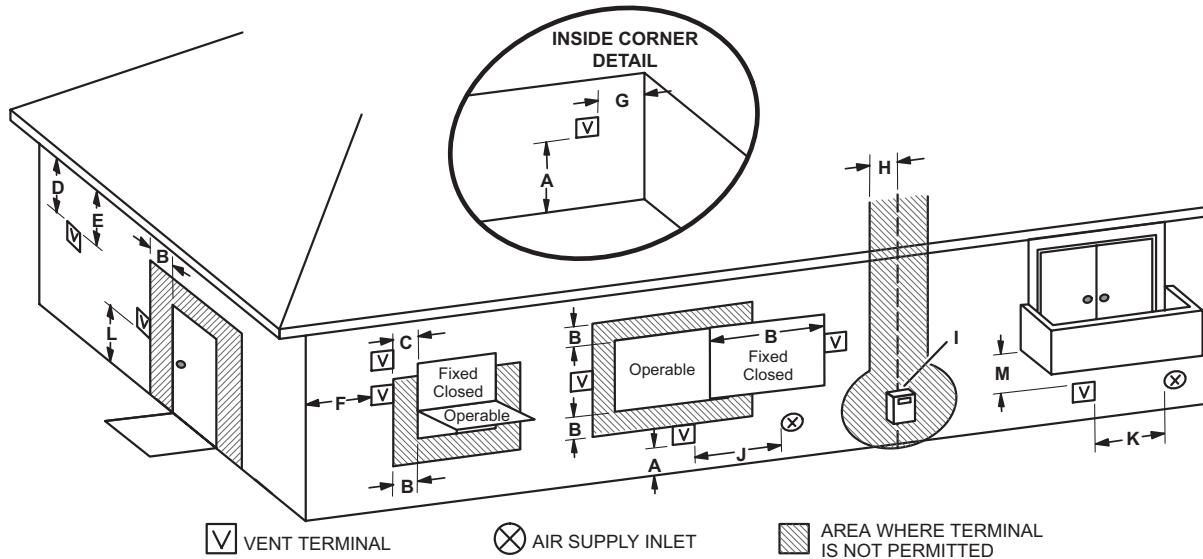
<sup>2</sup> In accordance with the current CSA B149.1, Natural Gas and Propane Installation Code  
 † A vent shall not terminate directly above a sidewalk or paved driveway that is located between two single family dwellings and serves both dwellings.

‡ Permitted only if veranda, porch, deck or balcony is fully open on a minimum of two sides beneath the floor. Lennox recommends avoiding this location if possible.

\*For clearances not specified in ANSI Z223.1/NFPA 54 or CSA B149.1, clearance will be in accordance with local installation codes and the requirements of the gas supplier and these installation instructions."

**FIGURE 32**

## VENT TERMINATION CLEARANCES FOR DIRECT VENT INSTALLATIONS IN THE US AND CANADA



	US Installations <sup>1</sup>	Canadian Installations <sup>2</sup>	
A =	Clearance above grade, veranda, porch, deck or balcony	12 inches (305mm) or 12 in. (305mm) above average snow accumulation.	12 inches (305mm) or 12 in. (305mm) above average snow accumulation.
B =	Clearance to window or door that may be opened	6 inches (152mm) for appliances <10,000 Btuh (3kw), 9 inches (228mm) for appliances > 10,000 Btuh (3kw) and <50,000 Btuh (15 kw), 12 inches (305mm) for appliances > 50,000 Btuh (15kw)	6 inches (152mm) for appliances <10,000 Btuh (3kw), 12 inches (305mm) for appliances > 10,000 Btuh (3kw) and <100,000 Btuh (30kw), 36 inches (.9m) for appliances > 100,000 Btuh (30kw)
C =	Clearance to permanently closed window	* 12"	* 12"
D =	Vertical clearance to ventilated soffit located above the terminal within a horizontal distance of 2 feet (610mm) from the center line of the terminal	* Equal to or greater than soffit depth	* Equal to or greater than soffit depth
E =	Clearance to unventilated soffit	* Equal to or greater than soffit depth	* Equal to or greater than soffit depth
F =	Clearance to outside corner	* No minimum to outside corner	* No minimum to outside corner
G =	Clearance to inside corner	*	*
H =	Clearance to each side of center line extended above meter / regulator assembly	3 feet (.9m) within a height 15 feet (4.5m) above the meter / regulator assembly	3 feet (.9m) within a height 15 feet (4.5m) above the meter / regulator assembly
I =	Clearance to service regulator vent outlet	* 3 feet (.9m)	3 feet (.9m)
J =	Clearance to non-mechanical air supply inlet to building or the combustion air inlet to any other appliance	6 inches (152mm) for appliances <10,000 Btuh (3kw), 9 inches (228mm) for appliances > 10,000 Btuh (3kw) and <50,000 Btuh (15 kw), 12 inches (305mm) for appliances > 50,000 Btuh (15kw)	6 inches (152mm) for appliances <10,000 Btuh (3kw), 12 inches (305mm) for appliances > 10,000 Btuh (3kw) and <100,000 Btuh (30kw), 36 inches (.9m) for appliances > 100,000 Btuh (30kw)
K =	Clearance to mechanical air supply inlet	3 feet (.9m) above if within 10 feet (3m) horizontally	6 feet (1.8m)
L =	Clearance above paved sidewalk or paved driveway located on public property	* 7 feet (2.1m)	7 feet (2.1m)†
M =	Clearance under veranda, porch, deck or balcony	*12 inches (305mm)‡	12 inches (305mm)‡

<sup>1</sup> In accordance with the current ANSI Z223.1/NFPA 54 Natural Fuel Gas Code

<sup>2</sup> In accordance with the current CSA B149.1, Natural Gas and Propane Installation Code

† A vent shall not terminate directly above a sidewalk or paved driveway that is located between two single family dwellings and serves both dwellings.

‡ Permitted only if veranda, porch, deck or balcony is fully open on a minimum of two sides beneath the floor. Lennox recommends avoiding this location if possible.

\*For clearances not specified in ANSI Z223.1/NFPA 54 or CSA B149.1, clearance will be in accordance with local installation codes and the requirements of the gas supplier and these installation instructions.\*

**FIGURE 33**

## Details of Intake and Exhaust Piping Terminations for Direct Vent Installations

**NOTE** - In Direct Vent installations, combustion air is taken from outdoors and flue gases are discharged to outdoors.

**NOTE** - Flue gas may be slightly acidic and may adversely affect some building materials. If any vent termination is used and the flue gases may impinge on the building material, a corrosion-resistant shield (minimum 24 inches square) should be used to protect the wall surface. If the optional tee is used, the protective shield is recommended. The shield should be constructed using wood, plastic, sheet metal or other suitable material. All seams, joints, cracks, etc. in the affected area should be sealed using an appropriate sealant. See FIGURE 42.

Intake and exhaust pipes may be routed either horizontally through an outside wall or vertically through the roof. In attic or closet installations, vertical termination through the roof is preferred. FIGURE 34 through FIGURE 41 show typical terminations.

1 - Intake and exhaust terminations are not required to be in the same pressure zone. You may exit the intake on one side of the structure and the exhaust on another side (FIGURE 35). You may exit the exhaust out the roof and the intake out the side of the structure (FIGURE 36).

2 - Intake and exhaust pipes should be placed as close together as possible at termination end (refer to illustrations). Maximum separation is 3" (76MM) on roof terminations and 6" (152MM) on side wall terminations.

**NOTE** - When venting in different pressure zones, the maximum separation requirement of intake and exhaust pipe DOES NOT apply.

3 - On roof terminations, the intake piping should terminate straight down using two 90° elbows (See FIGURE 34).

4 - Exhaust piping must terminate straight out or up as shown. A reducer may be required on the exhaust piping at the point where it exits the structure to improve the velocity of exhaust away from the intake piping. See TABLE 8.

**NOTE** - Care must be taken to avoid recirculation of exhaust back into intake pipe.

5 - On field-supplied terminations for side wall exit, exhaust piping may extend a maximum of 12 inches (305MM) for 2" PVC and 20 inches (508MM) for 3" (76MM) PVC beyond the outside wall. Intake piping should be as short as possible. See FIGURE 42.

6 - On field-supplied terminations, a minimum distance between the end of the exhaust pipe and the end of the intake pipe without a termination elbow is 8" and a minimum distance of 6" with a termination elbow. See FIGURE 42.

7 - If intake and exhaust piping must be run up a side wall to position above snow accumulation or other obstructions, piping must be supported.

At least one bracket must be used within 6" from the top of the elbow and then every 24" (610mm) as shown in FIGURE 42, to prevent any movement in any direction. When exhaust and intake piping must be run up an outside wall, the exhaust piping must be terminated with pipe sized per TABLE 8. The intake piping may be equipped with a 90° elbow turndown. Using turndown will add 5 feet (1.5m) to the equivalent length of the pipe.

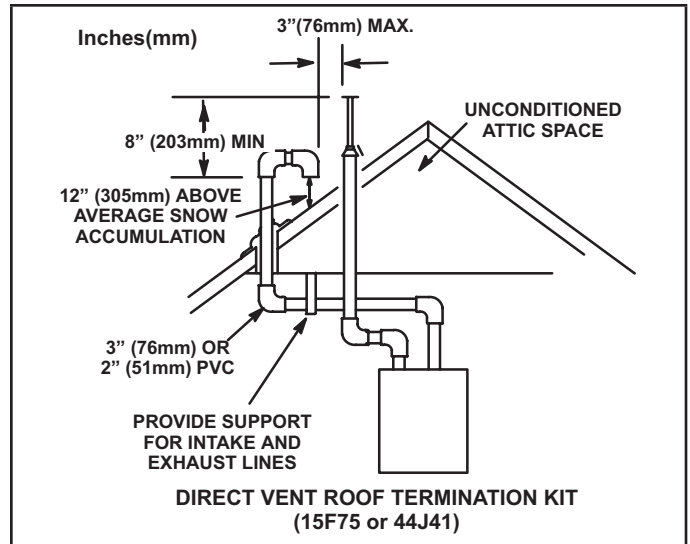


FIGURE 34

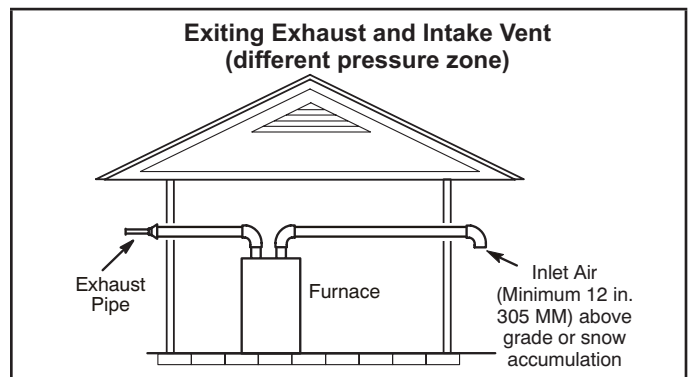


FIGURE 35

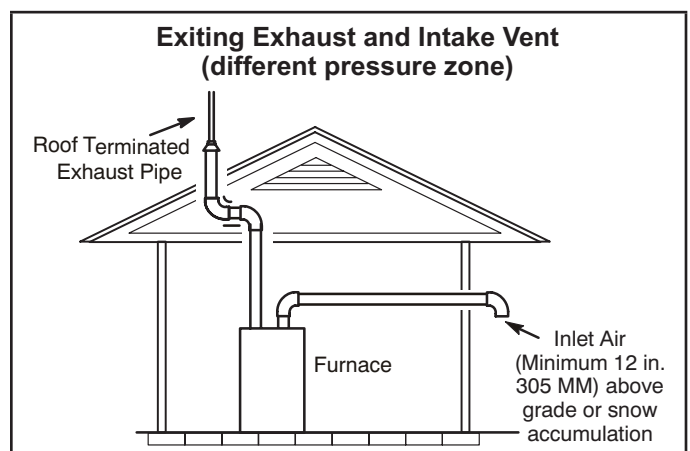


FIGURE 36

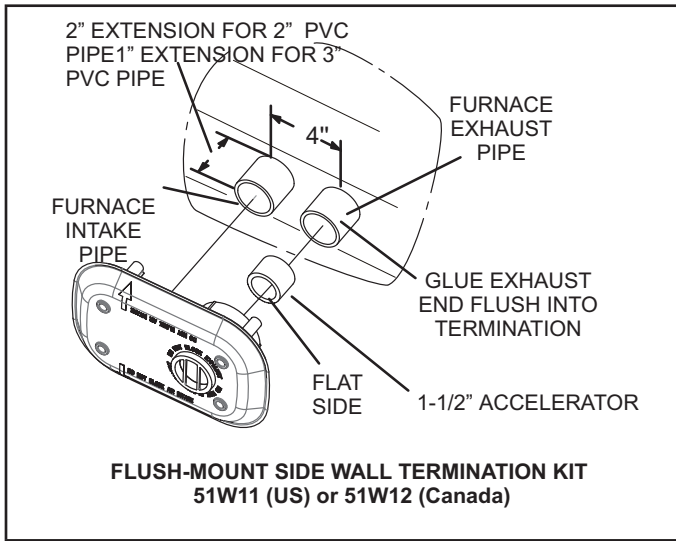
**TABLE 8**

**EXHAUST PIPE TERMINATION SIZE REDUCTION**

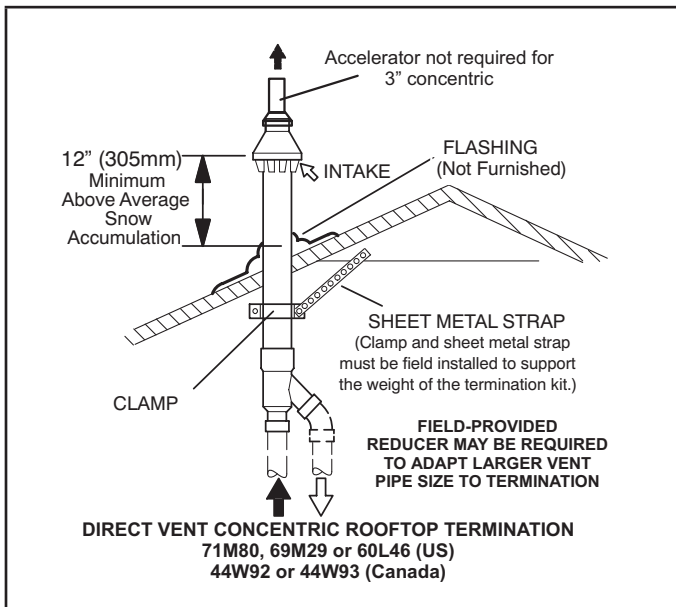
ML296UHV Model	Termination Pipe Size
*045 and 070	1-1/2" (38MM)
*090	2" (51MM)
110	2" (51MM)

\*ML296UHV-045, -070 and -090 units with the flush mount termination must use the 1-1/2" accelerator supplied with the kit.

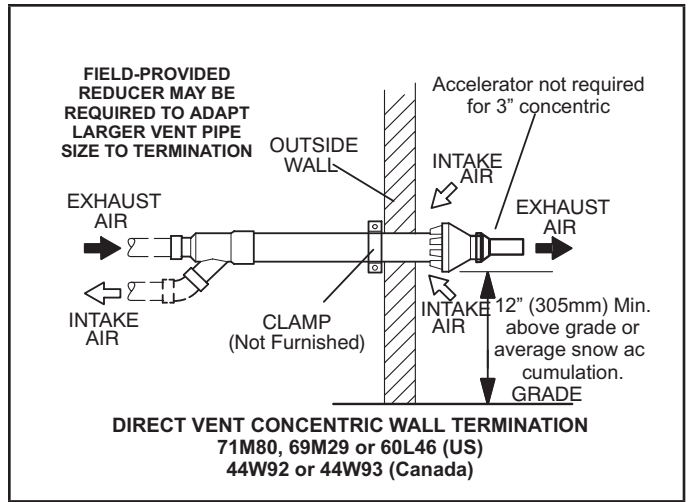
8 - A multiple furnace installation may use a group of up to four terminations assembled together horizontally, as shown in FIGURE 40.



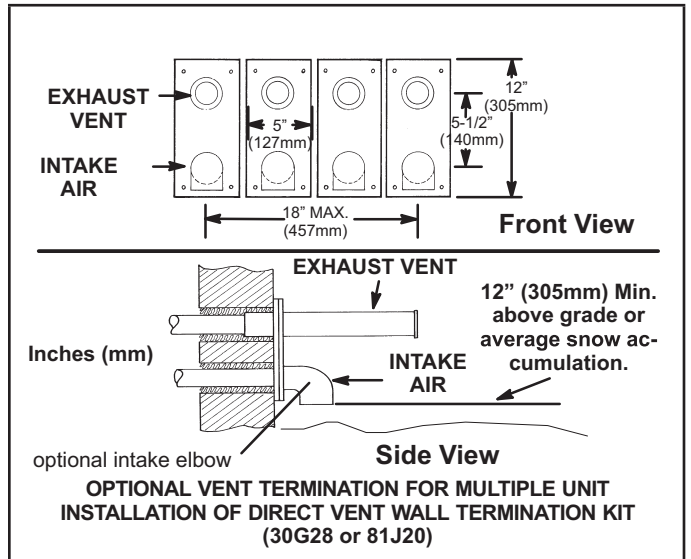
**FIGURE 37**



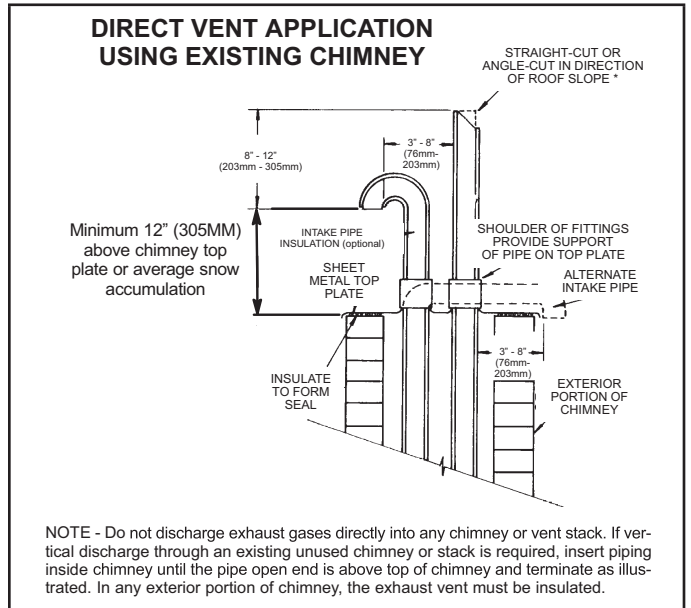
**FIGURE 38**



**FIGURE 39**



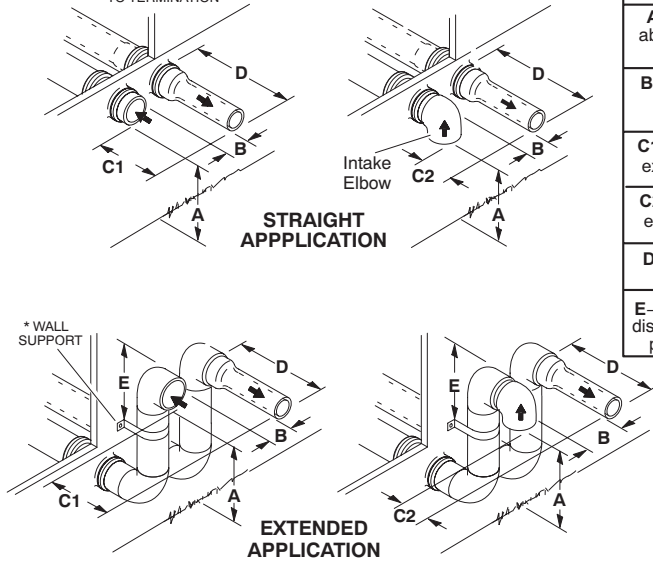
**FIGURE 40**



**FIGURE 41**

### FIELD FABRICATED WALL TERMINATION

NOTE - FIELD-PROVIDED REDUCER MAY BE REQUIRED TO ADAPT LARGER VENT PIPE SIZE TO TERMINATION

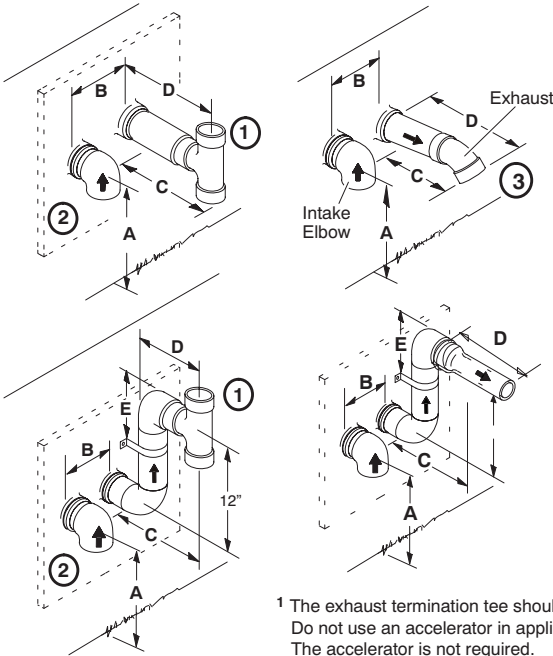


	2" (51mm) Vent Pipe	3" (76mm) Vent Pipe
A- Minimum clearance above grade or average snow accumulation	12" (305 mm)	12" (305 mm)
B- Maximum horizontal separation between intake and exhaust	6" (152 mm)	6" (152 mm)
C1 -Minimum from end of exhaust to inlet of intake	8" (203 mm)	8" (203 mm)
C2 -Minimum from end of exhaust to inlet of intake	6" (152 mm)	6" (152 mm)
D- Maximum exhaust pipe length	12" (305 mm)	20" (508 mm)
E- Maximum wall support distance from top of each pipe (intake/exhaust)	6" (152 mm)	6" (152 mm)

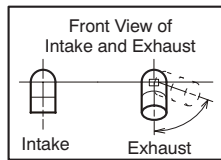
See venting table maximum venting lengths with this arrangement.

\* Use wall support every 24" (610 mm). Use two wall supports if extension is greater than 24" (610 mm) but less than 48" (1219 mm).  
NOTE - One wall support must be within 6" (152 mm) from top of each pipe (intake and exhaust) to prevent movement in any direction.

### ALTERNATE TERMINATIONS (TEE & FORTY-FIVE DEGREE ELBOWS ONLY)



	2" (51MM) Vent Pipe	3" (76MM) Vent Pipe
A- Clearance above grade or average snow accumulation	12" (305 mm) Min.	12" (305 mm) Min.
B- Horizontal separation between intake and exhaust	6" (152 mm) Min. 24" (610 mm) Max.	6" (152 mm) Min. 24" (610 mm) Max.
C- Minimum from end of exhaust to inlet of intake	9" (227 mm) Min.	9" (227 mm) Min.
D- Exhaust pipe length	12" (305 mm) Min. 16" (405 mm) Max.	12" (305 mm) Min. 20" (508 mm) Max.
E- Wall support distance from top of each pipe (intake/exhaust)	6" (152 mm) Max.	6" (152 mm) Max.



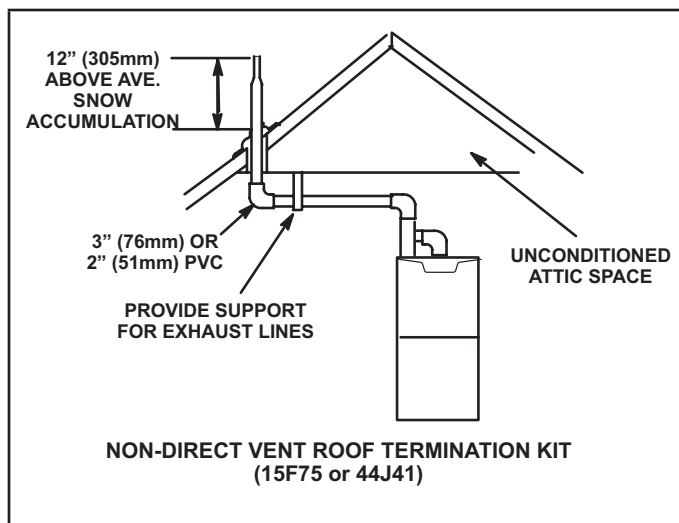
- 1 The exhaust termination tee should be connected to the 2" or 3" PVC flue pipe as shown in the illustration. Do not use an accelerator in applications that include an exhaust termination tee. The accelerator is not required.
- 2 As required. Flue gas may be acidic and may adversely affect some building materials. If a side wall vent termination is used and flue gases will impinge on the building materials, a corrosion-resistant shield (24 inches square) should be used to protect the wall surface. If optional tee is used, the protective shield is recommended. The shield should be constructed using wood, sheet metal or other suitable material. All seams, joints, cracks, etc. in affected area, should be sealed using an appropriate sealant.
- 3 Exhaust pipe 45° elbow can be rotated to the side away from the combustion air inlet to direct exhaust away from adjacent property. The exhaust must never be directed toward the combustion air inlet.

FIGURE 42

## Details of Exhaust Piping Terminations for No-Direct Vent Applications

Exhaust pipes may be routed either horizontally through an outside wall or vertically through the roof. In attic or closet installations, vertical termination through the roof is preferred. FIGURE 43 and FIGURE 44 show typical terminations.

- 1 - Exhaust piping must terminate straight out or up as shown. The termination pipe must be sized as listed in TABLE 8. The specified pipe size ensures proper velocity required to move the exhaust gases away from the building.
- 2 - On field supplied terminations for side wall exit, exhaust piping may extend a maximum of 12 inches (305MM) for 2" PVC and 20 inches (508MM) for 3" (76MM) PVC beyond the outside wall.



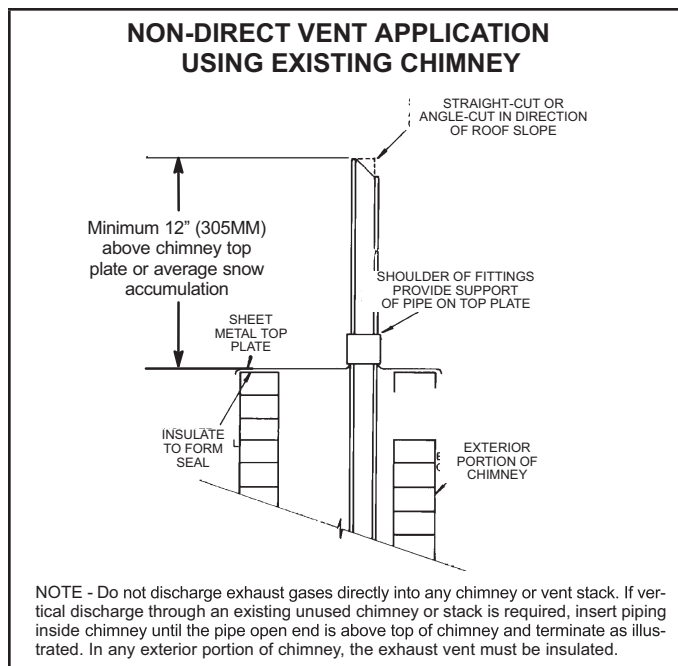
**FIGURE 43**

- 3 - If exhaust piping must be run up a side wall to position above snow accumulation or other obstructions, piping must be supported every 24 inches (610MM). When exhaust piping must be run up an outside wall, any reduction in exhaust pipe size must be done after the final elbow.
- 4 - Distance between exhaust pipe terminations on multiple furnaces must meet local codes.

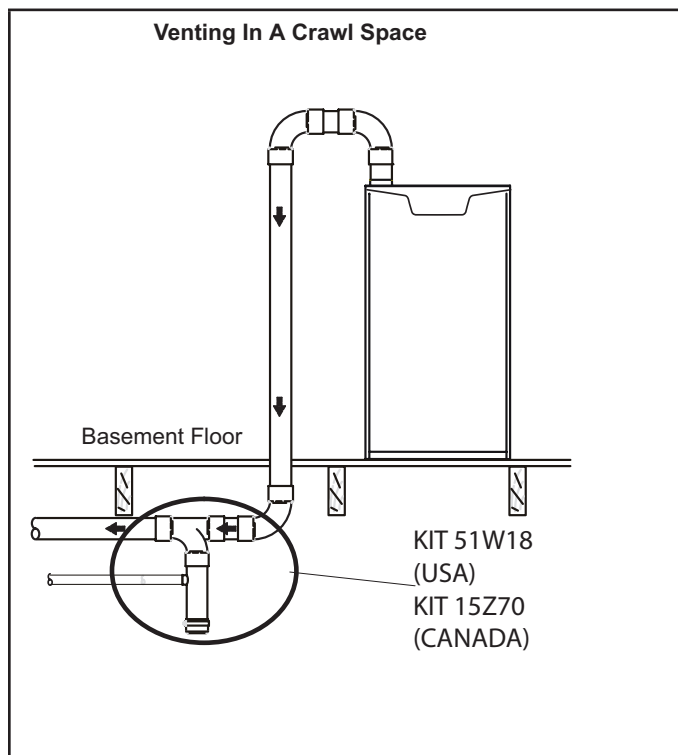
### Crawl Space and Extended Horizontal Venting

Lennox provides kit 51W18 to install 2" or 3" PVC exhaust piping through the floor joists and into the crawl space. See FIGURE 45.

This kit can also be used as a supplemental drain for installations with condensate run back in the vent pipe (ie. long horizontal runs, unconditioned spaces, etc.).



**FIGURE 44**



**FIGURE 45**

## Condensate Piping

This unit is designed for either right- or left-side exit of condensate piping in upflow applications. In horizontal applications, the condensate trap must extend below the unit. An 8" service clearance is required for the condensate trap. Refer to FIGURE 46 and FIGURE 48 for condensate trap locations. FIGURE 54 shows trap assembly using 1/2" PVC or 3/4" PVC.

**NOTE** - If necessary the condensate trap may be installed up to 5' away from the furnace. Use PVC pipe to connect trap to furnace condensate outlet. Piping from furnace must slope down a minimum of 1/4" per ft. toward trap.

- 1 - Determine which side condensate piping will exit the unit, location of trap, field-provided fittings and length of PVC pipe required to reach available drain.
- 2 - Use a large flat head screw driver or a 1/2" drive socket extension and remove plug (FIGURE 46) from the cold end header box at the appropriate location on the side of the unit. Install provided 3/4 NPT street elbow fitting into cold end header box. Use Teflon tape or appropriate pipe dope.

**NOTE** - Cold end header box drain plugs are factory installed. Check the unused plug for tightness to prevent leakage.

- 3 - Install the cap over the clean out opening at the base of the trap. Secure with clamp. See FIGURE 54.
- 4 - Install drain trap using appropriate PVC fittings, glue all joints. Glue the provided drain trap as shown in FIGURE 54. Route the condensate line to an open drain. Condensate line must maintain a 1/4" downward slope from the furnace to the drain.
- 5 - FIGURE 49 and FIGURE 50 show the furnace and evaporator coil using a separate drain. If necessary the condensate line from the furnace and evaporator coil can drain together. See FIGURE 51, FIGURE 52 and FIGURE 53. **Upflow furnace (FIGURE 52)** - In upflow furnace applications the field provided vent must be a minimum 1" to a maximum 2" length above the condensate drain outlet connection. Any length above 2" may result in a flooded heat exchanger if the combined primary drain line were to become restricted.

**Horizontal furnace (FIGURE 53)** - In horizontal furnace applications the field provided vent must be a minimum 4" to a maximum 5" length above the condensate drain outlet connection. Any length above 5" may result in a flooded heat exchanger if the combined primary drain line were to become restricted.

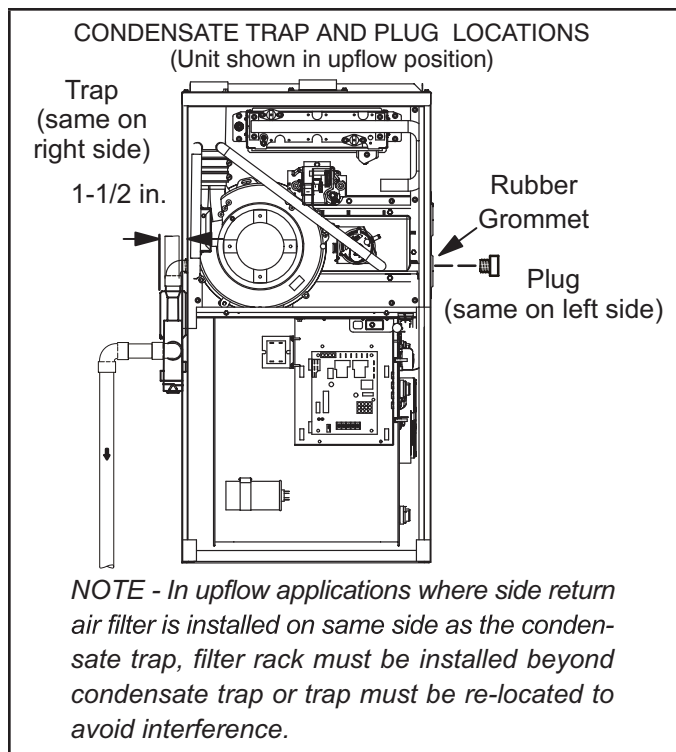


FIGURE 46

**NOTE** - In horizontal applications it is recommended to install a secondary drain pan underneath the unit and trap assembly.

**NOTE** - Appropriately sized tubing and barbed fitting may be used for condensate drain. Attach to the drain on the trap using a hose clamp. See FIGURE 47.

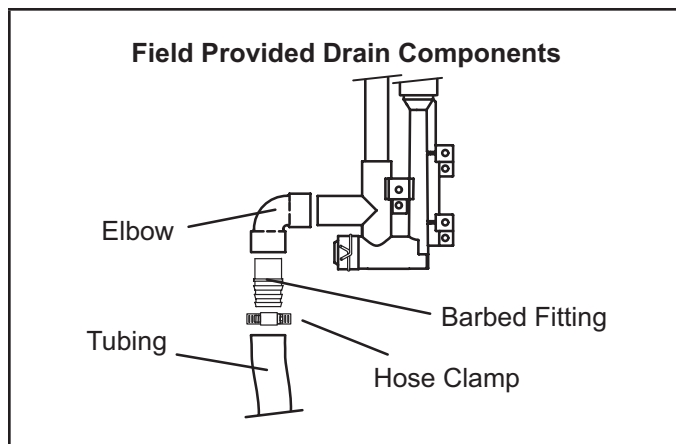


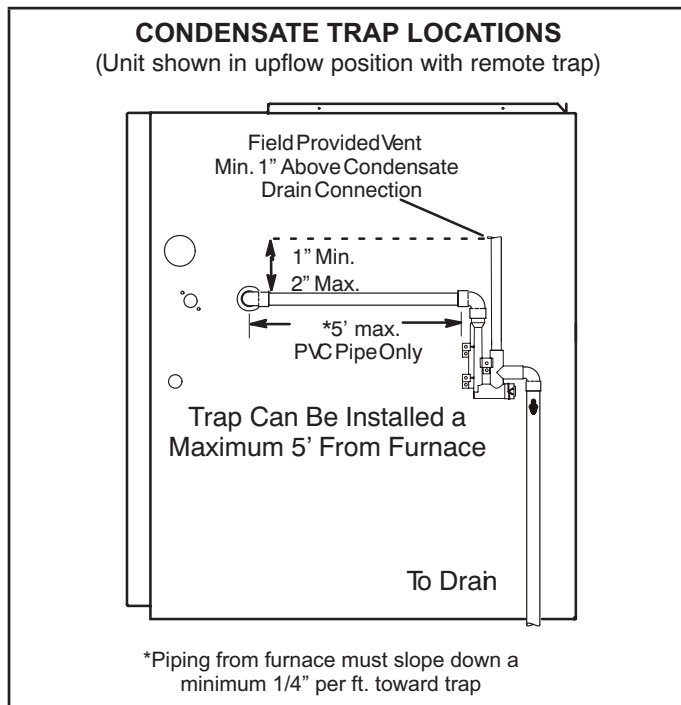
FIGURE 47

## CAUTION

Do not use copper tubing or existing copper condensate lines for drain line.

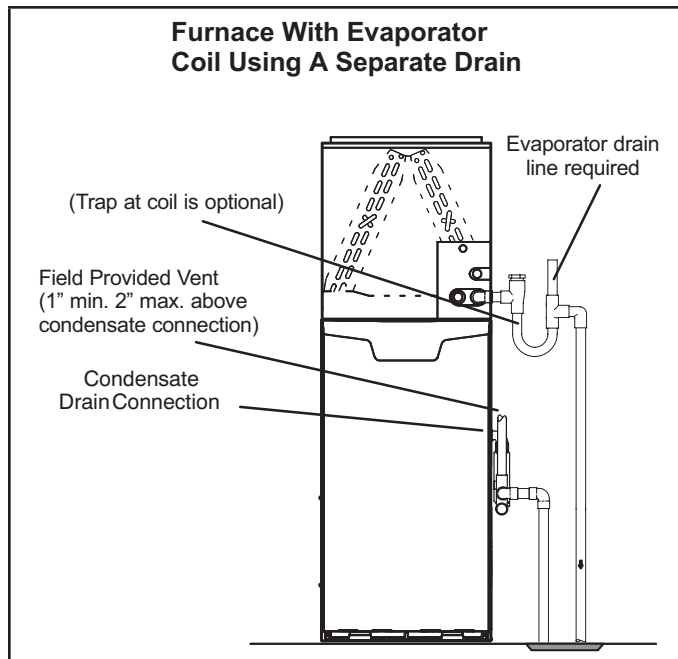


6 - If unit will be started immediately upon completion of installation, prime trap per procedure outlined in Unit Start-Up section.

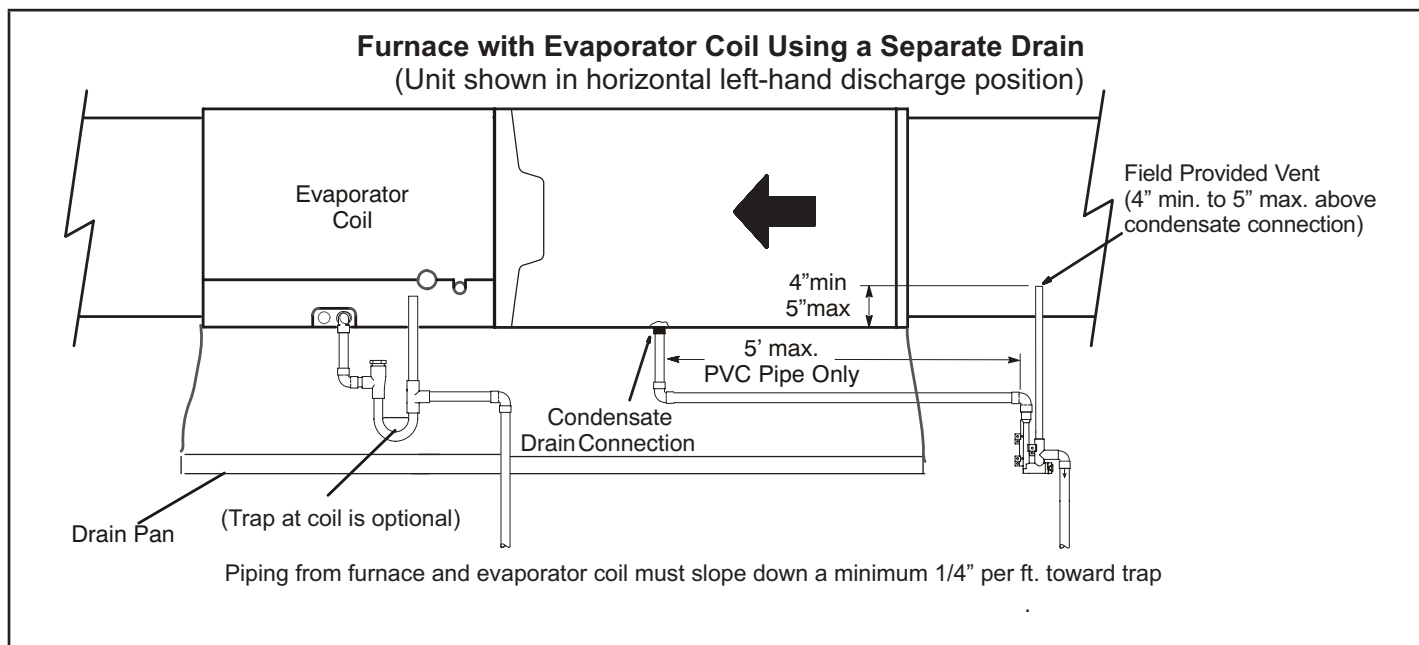


**FIGURE 48**

Condensate line must slope downward away from the trap to drain. If drain level is above condensate trap, condensate pump must be used. Condensate drain line should be routed within the conditioned space to avoid freezing of condensate and blockage of drain line. If this is not possible, a heat cable kit may be used on the condensate trap and line. Heating cable kit is available from Lennox in various lengths; 6 ft. (1.8m) - kit no. 26K68; 24 ft. (7.3m) - kit no. 26K69; and 50 ft. (15.2m) - kit no. 26K70.



**FIGURE 49**



**FIGURE 50**

# ⚠ IMPORTANT

When combining the furnace and evaporator coil drains together, the A/C condensate drain outlet must be vented to relieve pressure in order for the furnace pressure switch to operate properly.

## Condensate Trap With Optional Overflow Switch

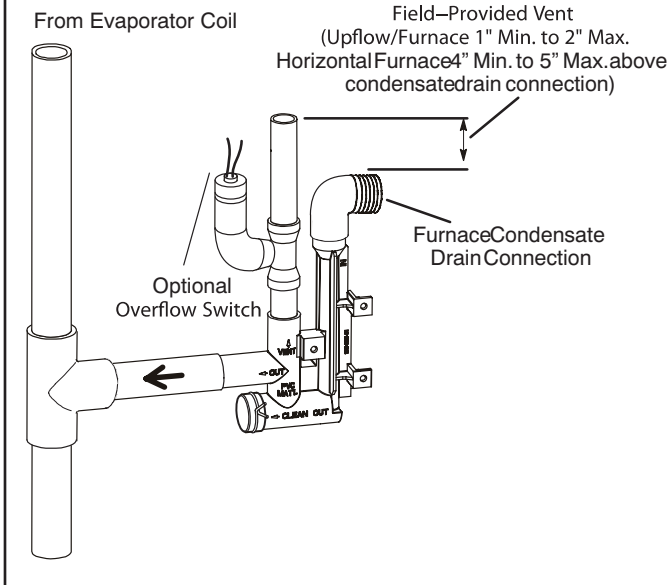


FIGURE 51

## Furnace with Evaporator Coil Using a Common Drain

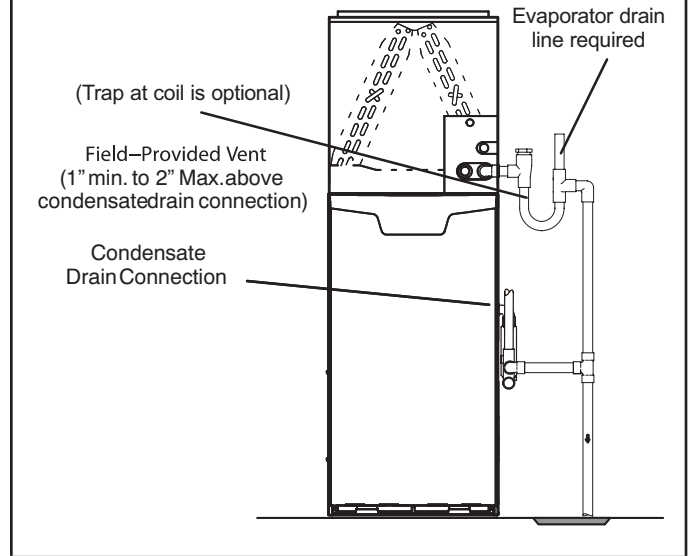


FIGURE 52

## Furnace with Evaporator Coil Using a Common Drain

(Unit shown in horizontal left-hand discharge position)

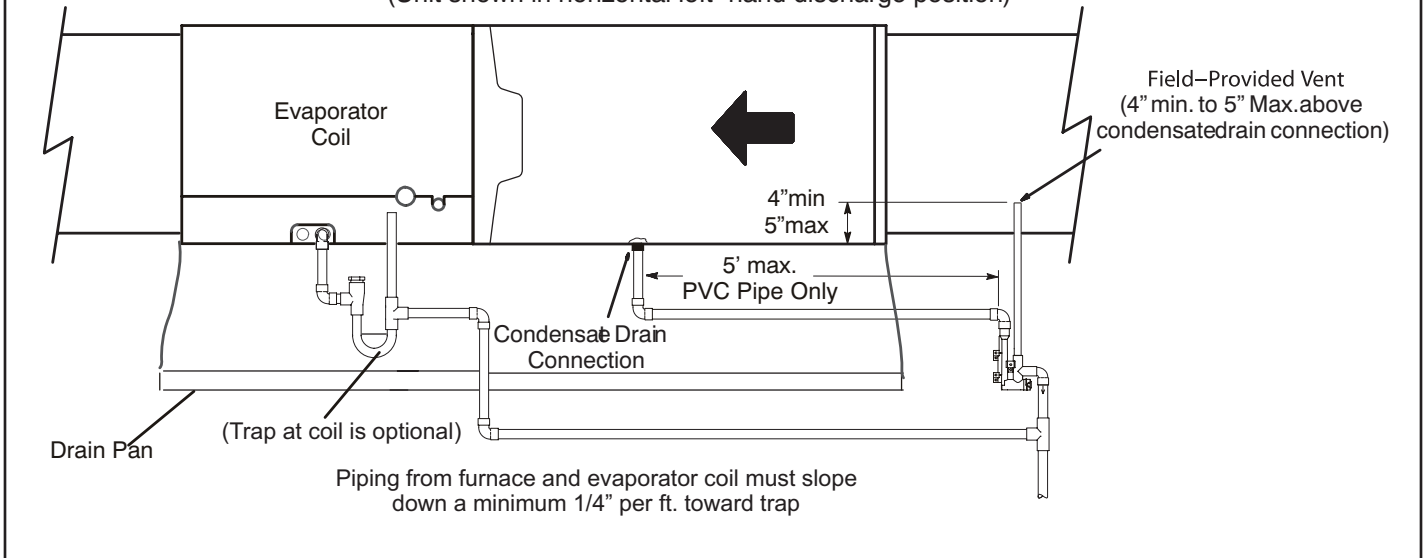
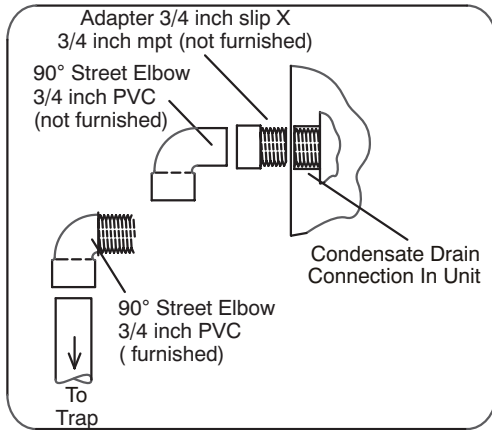


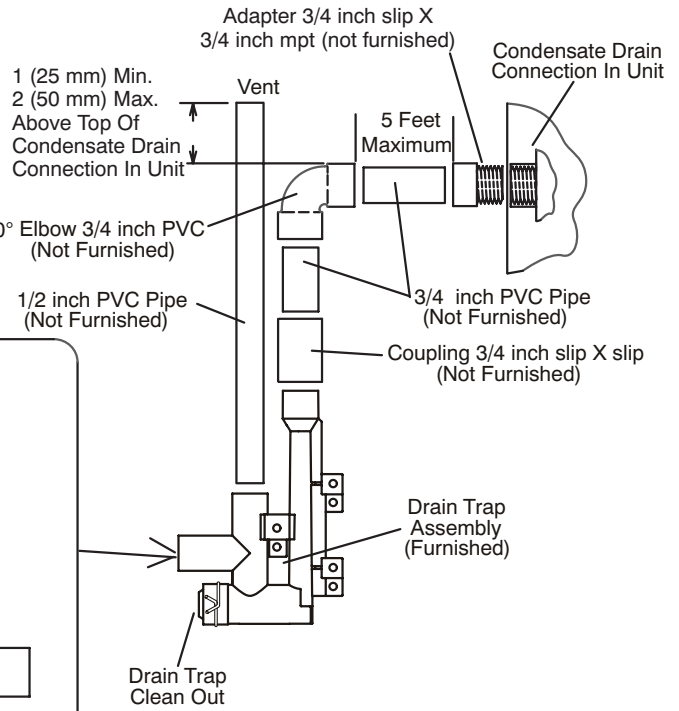
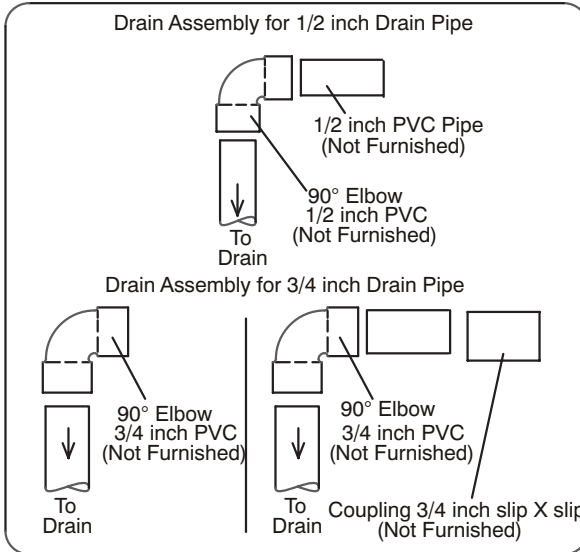
FIGURE 53

**TRAP / DRAIN ASSEMBLY USING 1/2" PVC OR 3/4" PVC**

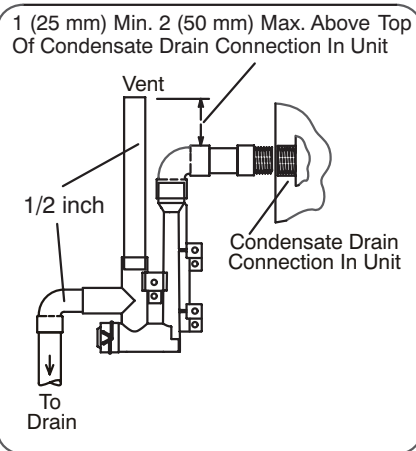
Optional Condensate Drain Connection



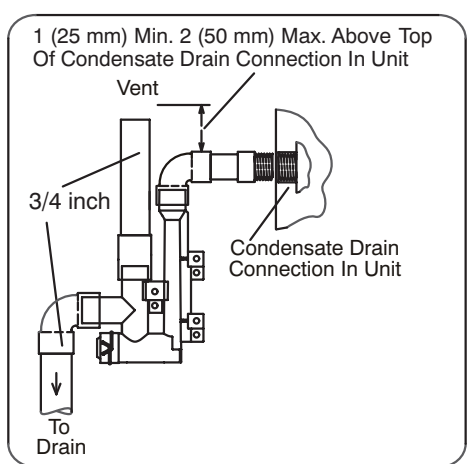
Optional Drain Piping From Trap



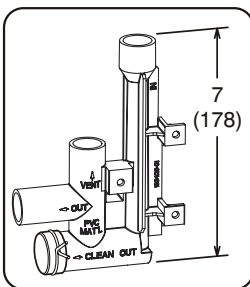
Drain Trap Assembly with 1/2 inch Piping



Drain Trap Assembly with 3/4 inch Piping



Drain Trap Assembly (Furnished)



**FIGURE 54**

## Gas Piping

Gas supply piping should not allow more than 0.5"W.C. drop in pressure between gas meter and unit. Supply gas pipe must not be smaller than unit gas connection.

## ⚠ CAUTION

If a flexible gas connector is required or allowed by the authority that has jurisdiction, black iron pipe shall be installed at the gas valve and extend outside the furnace cabinet. The flexible connector can then be added between the black iron pipe and the gas supply line.

## ⚠ WARNING

Do not over torque (800 in-lbs) or under torque (350 in-lbs) when attaching the gas piping to the gas valve.

- 1 - Gas piping may be routed into the unit through either the left- or right-hand side. Supply piping enters into the gas valve from the side of the valve as shown in FIGURE 56. Connect the gas supply piping into the gas valve. The maximum torque is 800 in lbs and minimum torque is 350 in lbs when attaching the gas piping to the gas valve.
- 2 - When connecting gas supply, factors such as length of run, number of fittings and furnace rating must be considered to avoid excessive pressure drop. TABLE 9 lists recommended pipe sizes for typical applications.  
**NOTE** - Use two wrenches when connecting gas piping to avoid transferring torque to the manifold.
- 3 - Gas piping must not run in or through air ducts, clothes chutes, chimneys or gas vents, dumb waiters or elevator shafts. Center gas line through piping hole. Gas line should not touch side of unit. See FIGURE 56 and FIGURE 57.
- 4 - Piping should be sloped 1/4 inch per 15 feet (6mm per 5.6m) upward toward the gas meter from the furnace. The piping must be supported at proper intervals, every 8 to 10 feet (2.44 to 3.05m), using suitable hangers or straps. Install a drip leg in vertical pipe runs to serve as a trap for sediment or condensate.
- 5 - A 1/8" N.P.T. plugged tap or pressure post is located on the gas valve to facilitate test gauge connection. See FIGURE 63.
- 6 - In some localities, codes may require installation of a manual main shut-off valve and union (furnished by installer) external to the unit. Union must be of the ground joint type.

## ⚠ IMPORTANT

Compounds used on threaded joints of gas piping must be resistant to the actions of liquefied petroleum gases.

### Leak Check

After gas piping is completed, carefully check all piping connections (factory- and field-installed) for gas leaks. Use a leak detecting solution or other preferred means.

Never use an open flame to test for gas leaks. Check all connections using a commercially available soap solution made specifically for leak detection.

*The furnace must be isolated from the gas supply system by closing its individual manual shut-off valve during any pressure testing of the gas supply system at pressures greater than or equal to 1/2 psig (3.48 kPa, 14 inches w.c.)*

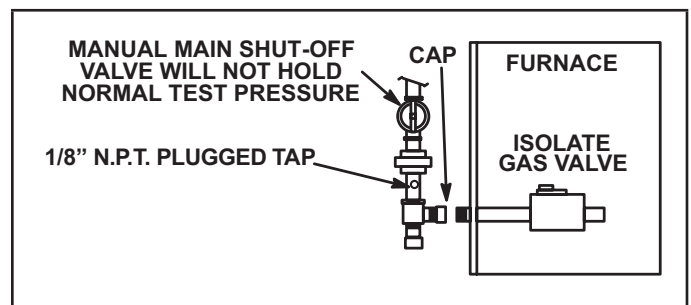


FIGURE 55

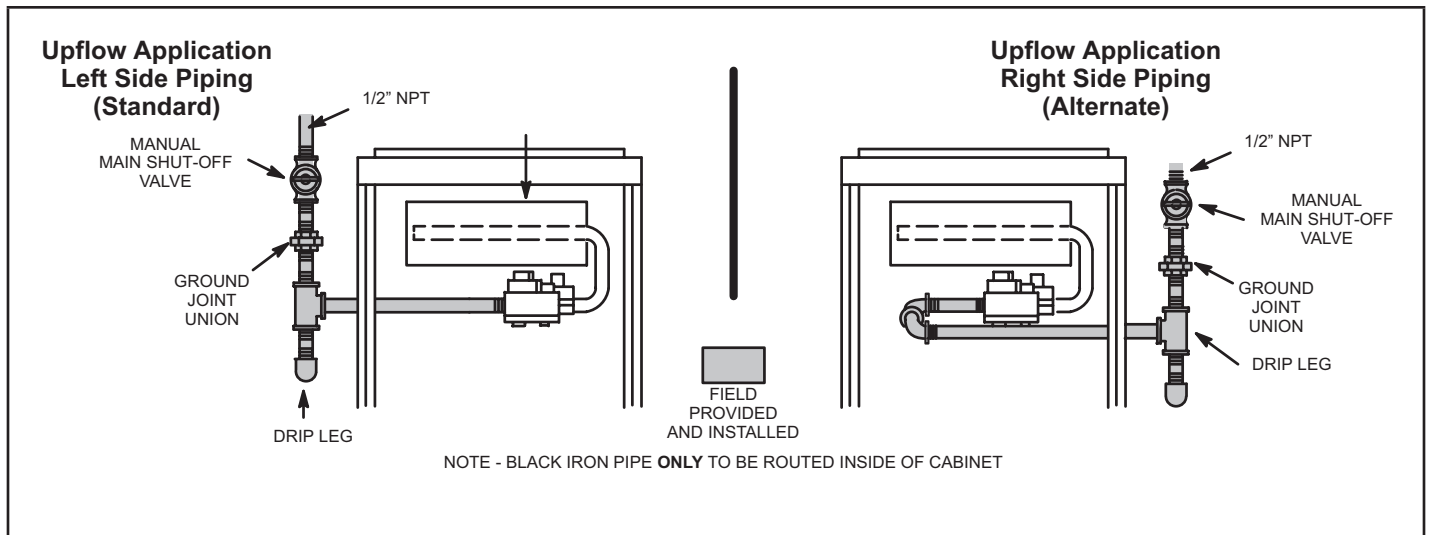
## ⚠ IMPORTANT

When testing pressure of gas lines, gas valve must be disconnected and isolated. See FIGURE 55. Gas valves can be damaged if subjected to pressures greater than 1/2 psig (3.48 kPa).

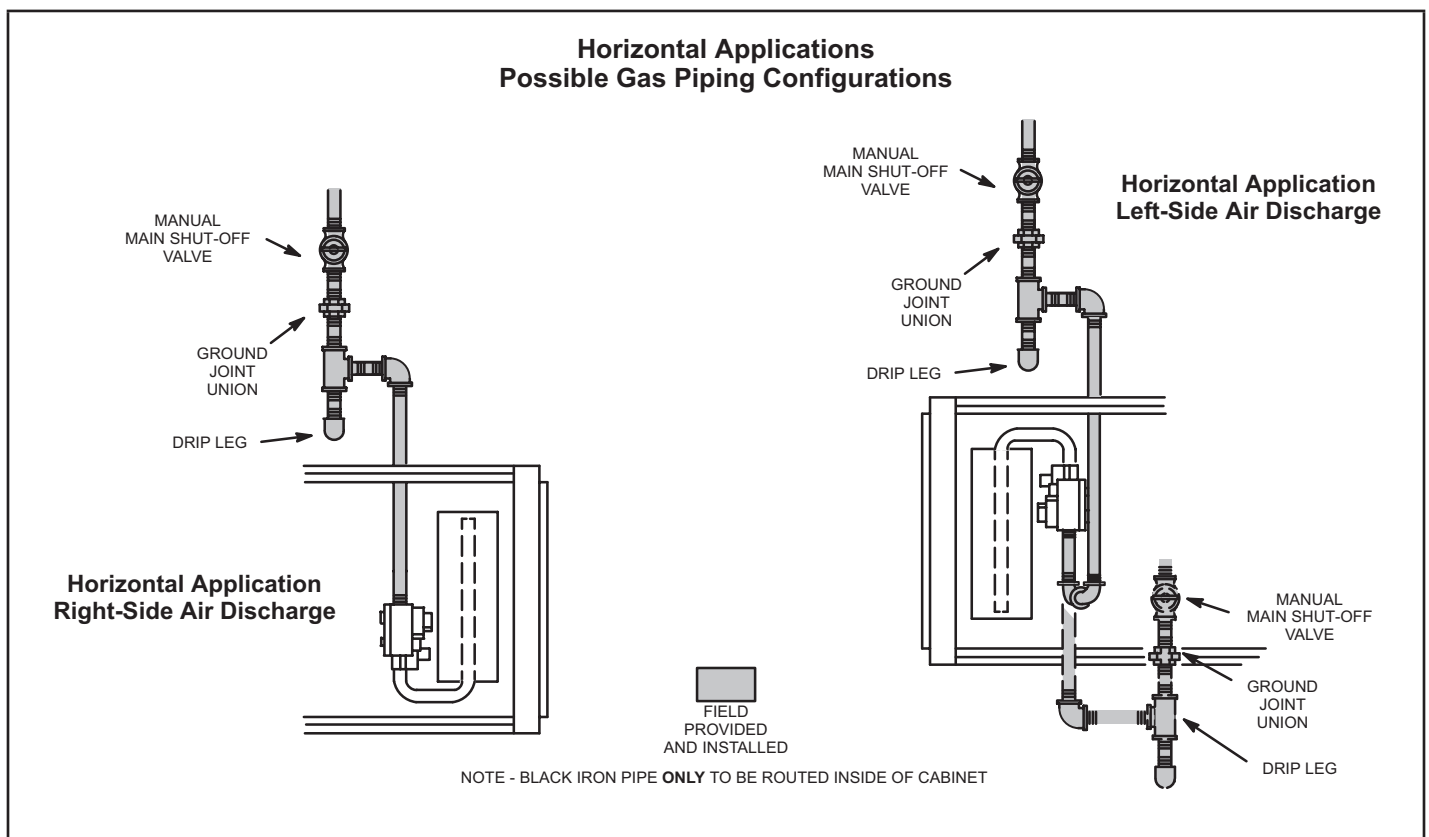
## ⚠ WARNING

### FIRE OR EXPLOSION HAZARD

Failure to follow the safety warnings exactly could result in serious injury, death, or property damage. Never use an open flame to test for gas leaks. Check all connections using a commercially available soap solution made specifically for leak detection. Some soaps used for leak detection are corrosive to certain metals. Carefully rinse piping thoroughly after leak test has been completed.



**FIGURE 56**



**FIGURE 57**

**TABLE 9**  
**Gas Pipe Capacity - ft3/hr (m3/hr)**

Nominal Iron Pipe Size Inches (mm)	Internal Diameter inches (mm)	Length of Pipe - feet (m)									
		10 (3.048)	20 (6.096)	30 (9.144)	40 (12.192)	50 (15.240)	60 (18.288)	70 (21.336)	80 (24.384)	90 (27.432)	100 (30.480)
1/2 (12.7)	.622 (17.799)	172 (4.87)	118 (3.34)	95 (2.69)	81 (2.29)	72 (2.03)	65 (1.84)	60 (1.69)	56 (1.58)	52 (1.47)	50 (1.42)
3/4 (19.05)	.824 (20.930)	360 (10.19)	247 (7.000)	199 (5.63)	170 (4.81)	151 (4.23)	137 (3.87)	126 (3.56)	117 (3.31)	110 (3.11)	104 (2.94)
1 (25.4)	1.049 (26.645)	678 (19.19)	466 (13.19)	374 (10.59)	320 (9.06)	284 (8.04)	257 (7.27)	237 (6.71)	220 (6.23)	207 (5.86)	195 (5.52)
1-1/4 (31.75)	1.380 (35.052)	1350 (38.22)	957 (27.09)	768 (22.25)	657 (18.60)	583 (16.50)	528 (14.95)	486 (13.76)	452 (12.79)	424 (12.00)	400 (11.33)
1-1/2 (38.1)	1.610 (40.894)	2090 (59.18)	1430 (40.49)	1150 (32.56)	985 (27.89)	873 (24.72)	791 (22.39)	728 (20.61)	677 (19.17)	635 (17.98)	600 (17.00)
2 (50.8)	2.067 (52.502)	4020 (113.83)	2760 (78.15)	2220 (62.86)	1900 (53.80)	1680 (47.57)	1520 (43.04)	1400 (39.64)	1300 (36.81)	1220 (34.55)	1160 (32.844)
2-1/2 (63.5)	2.469 (67.713)	6400 (181.22)	4400 (124.59)	3530 (99.95)	3020 (85.51)	2680 (75.88)	2480 (70.22)	2230 (63.14)	2080 (58.89)	1950 (55.22)	1840 (52.10)
3 (76.2)	3.068 (77.927)	11300 (319.98)	7780 (220.30)	6250 (176.98)	5350 (151.49)	4740 (134.22)	4290 (121.47)	3950 (111.85)	3670 (103.92)	3450 (97.69)	3260 (92.31)

**NOTE - Capacity given in cubic feet (m3 ) of gas per hour and based on 0.60 specific gravity gas.**

## Electrical

### ELECTROSTATIC DISCHARGE (ESD) Precautions and Procedures

#### ⚠ CAUTION



Electrostatic discharge can affect electronic components. Take precautions to neutralize electrostatic charge by touching your hand and tools to metal prior to handling the control.

#### ⚠ WARNING



Electric Shock Hazard. Can cause injury or death. Unit must be properly grounded in accordance with national and local codes.

#### ⚠ WARNING

Fire Hazard. Use of aluminum wire with this product may result in a fire, causing property damage, severe injury or death. Use copper wire only with this product.

The unit is equipped with a field make-up box on the left hand side of the cabinet. The make-up box may be moved to the right side of the furnace to facilitate installation. If the make-up box is moved to the right side, clip the wire ties that bundle the wires together. The excess wire must be pulled into the blower compartment. Secure the excess wire to the existing harness to protect it from damage.

#### INTERIOR MAKE-UP BOX INSTALLATION

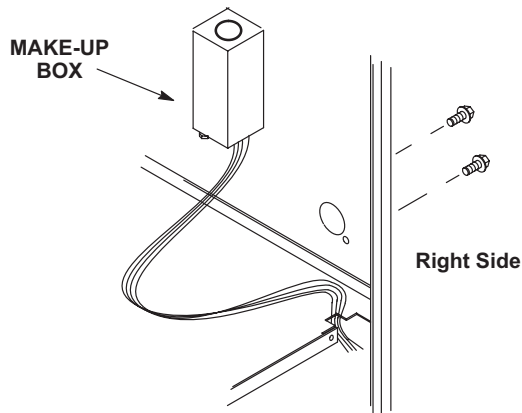


FIGURE 58

The power supply wiring must meet Class I restrictions. Protected by either a fuse or circuit breaker, select circuit protection and wire size according to unit nameplate.

#### ⚠ CAUTION

Failure to use properly sized wiring and circuit breaker may result in property damage. Size wiring and circuit breaker(s) per Product Specifications bulletin (EHB) and unit rating plate.

**NOTE** - Unit nameplate states maximum current draw. Maximum over-current protection allowed is shown in TABLE 10.

TABLE 10

ML296UHV	Maximum Over-Current
045V36B, 070V36B, 090V48C	15
110V60C	20

Holes are on both sides of the furnace cabinet to facilitate wiring.

Install a separate (properly sized) disconnect switch near the furnace so that power can be turned off for servicing.

Before connecting the thermostat or the power wiring, check to make sure the wires will be long enough for servicing at a later date. Remove the blower access panel to check the length of the wire.

Complete the wiring connections to the equipment. Use the provided unit wiring diagram and the field wiring diagram shown in FIGURE 61. Use 18-gauge wire or larger that is suitable for Class II rating for thermostat connections.

Electrically ground the unit according to local codes or, in the absence of local codes, according to the current National Electric Code (ANSI/NFPA No. 70). A green ground wire is provided in the field make-up box. **NOTE** - The ML296UHV furnace contains electronic components that are polarity sensitive. Make sure that the furnace is wired correctly and is properly grounded.

One line voltage "EAC" 1/4" spade terminal is provided on the furnace integrated control. Any electronic air M cleaner or other accessory rated up to one amp can be connected to this terminal with the neutral leg of the circuit being connected to one of the provided neutral terminals. See FIGURE 62 for control configuration. This terminal is energized when the indoor blower is operating.

One line voltage “HUM” 1/4” spade terminal is provided on the furnace integrated control. Any humidifier rated up to one amp can be connected to this terminal with the neutral leg of the circuit being connected to one of the provided neutral terminals. See FIGURE 62 for control configuration. This terminal is energized in the heating mode whenever the combustion air inducer is operating.

Install the room thermostat according to the instructions provided with the thermostat. If the furnace is being matched with a heat pump, refer to the instruction packaged with the dual fuel thermostat.

#### Indoor Blower Speeds

When the thermostat is set to “FAN ON,” the indoor blower will run continuously at approximately 50% of the second stage cooling speed when there is no cooling or heating demand.

When the unit is running in the heating mode, the indoor blower will run on the heating speed designated by the positions of DIP switches (A, B, C, D) of the HEAT jumper. See FIGURE 59. When the unit is running in the cooling mode, the indoor blower will run on the cooling speed designated by the positions of DIP switches (A, B, C, D) of the COOL jumper. See FIGURE 59.

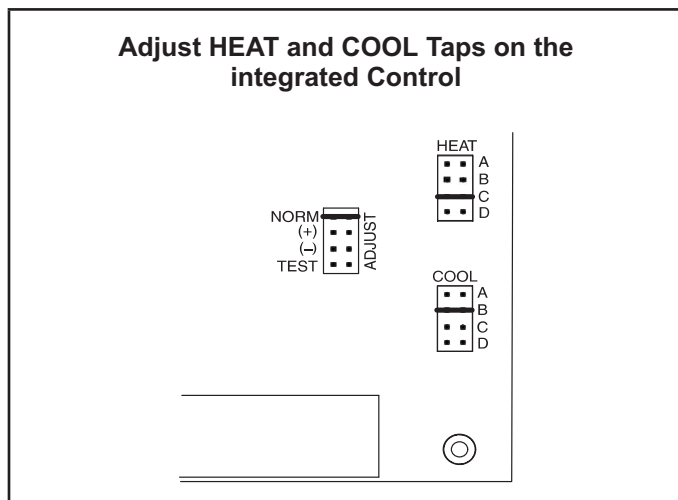


FIGURE 59

#### Generator Use - Voltage Requirements

The following requirements must be kept in mind when specifying a generator for use with this equipment:

- The furnace requires 120 volts (Range: 102 volts to 132 volts)
- The furnace operates at 60 Hz + 5% (Range: 57 Hz to 63 Hz)
- The furnace integrated control requires both correct polarity and proper ground. Both polarity and proper grounding should be checked before attempting to operate the furnace on either permanent or temporary power
- Generator should have a wave form distortion of less than 5% THD (total harmonic distortion)

#### Electrical Wiring

The furnace must be grounded and wired in accordance with local codes or, in the absence of local codes, with the National Electrical Code ANSI/NFPA No. 70 (latest edition) and/or CSA C22.1 Electrical Code (latest edition) if an external electrical source is utilized.

In all instances, other than wiring for the thermostat, the wiring to be done and any replacement of wire shall conform with the temperature limitation for Type T wire –635F (355C) rise.

Connect a sufficiently sized wire with ground to the furnace’s line voltage connections and ground wire. Refer to the furnace rating plate for electrical characteristics to be used in sizing field supply wiring and over current protection.

The line voltage supply should be routed through a readily accessible disconnect located within sight of the furnace. A junction box on the furnace side panel is provided for line voltage connections. Refer to the furnace wiring diagram for specific connection information.

**Proper polarity of the supply connections (“HOT” and “NEUTRAL”) must be observed to ensure that safety controls provide the protection intended.**

A connection to the unit’s ground wire and actual earth ground (typically a ground stake or buried steel pipe) must be maintained for proper operation.

#### Thermostat Selection

Install a room thermostat according to the instructions furnished with it. Select a location on an inside wall that is not subject to drafts, direct sunshine, or other heat sources. The initial heat anticipator setting should be equal to the total current draw of the control circuit. Low voltage thermostat connections are to be made to the integrated ignition/ blower control board as indicated on the wiring diagram.

#### Single Stage Thermostat Operation

##### Heating

The automatic heat staging option allows a single stage thermostat to be used with two stage furnace models. To activate this option, move the jumper pin (see Figure 60) to desired setting (5 minutes or 10 minutes). The furnace will start on 1st stage heat and stay at 1st stage heat for the duration of the selected time before switching to 2nd stage heat.

W1 on the integrated control must be connected to W1 on the thermostat.

##### Cooling

The unit is set up at the factory for single stage cooling. For two stage cooling operation, clip the jumper wire located between the Y to Y2 terminals on the integrated ignition/ blower control board. If the active dehumidification feature is enabled, the circulating blower runs at 70% of the selected cooling speed as long as there is a call for dehumidification.



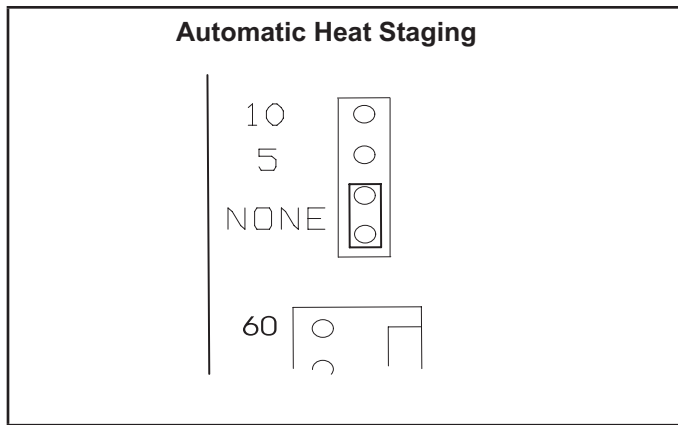


FIGURE 60

### Humidifier

Terminals are provided on the integrated ignition/blower control for connection to a 120-volt humidifier. The "HUM" terminal is energized whenever the thermostat calls for heat. See the furnace wiring diagram for specific connection information.

### Electronic Air Cleaner

Terminals are provided on the integrated ignition/blower control board for connection of a 120-volt electronic air cleaner. The "EAC" terminal is energized whenever the thermostat calls for heat, cooling, or continuous blower. See furnace wiring diagram for specific connection information.

### Variable Speed Features

This furnace is equipped with a variable speed circulation air blower motor that will deliver a constant airflow within a wide range of external static pressures. Other features of this variable speed motor include:

#### Soft Start

The variable speed motor will slowly ramp up to normal operating speed. This minimizes noise and increases comfort by eliminating the initial blasts of air encountered with standard motors.

#### Soft Stop

At the end of a cooling or heating cycle, the variable speed motor will slowly ramp down after a short blower "off" delay. If continuous blower operation has been selected, the variable speed motor will slowly ramp down until it reaches the airflow for that mode.

### Passive and Active Dehumidification

Both the passive and active dehumidification methods described below can be utilized on the same furnace.

#### Passive Dehumidification

For situations where humidity control is a problem, a dehumidification feature has been built into the variable speed motor. At the start of each cooling cycle, the variable speed motor will run at 82% of the rated airflow for 7.5 minutes. After 7.5 minutes has elapsed, the motor will increase to 100% of the rated airflow.

### Active Dehumidification

To achieve additional dehumidification, clip the jumper wire located below the DEHUM terminal on the integrated ignition/ blower control board and connect a humidity control that opens on humidity rise to the DEHUM and R terminals. The DEHUM terminal on the control board must be connected to the normally closed contact of the humidity control so that the board senses an open circuit on high humidity. In this setup, the variable speed motor will operate at a 30% reduction in the normal cooling airflow rate when there is a call for dehumidification.

### Circulating Airflow Adjustments

#### Cooling Mode

The units are factory set for the highest airflow for each model. Adjustments can be made to the cooling airflow by repositioning the jumper plug marked COOL – A, B, C, D (see FIGURE 59). To determine what CFM the motor is delivering at any time, count the number of times the amber LED on the control board flashes. Each flash signifies 100 CFM; count the flashes and multiply by 100 to determine the actual CFM delivered (for example: 5 flashes x 100 = 500 CFM).

#### Heating Mode

These units are factory set to run at the middle of the heating rise range as shown on the unit rating plate. If higher or lower rise is desired, reposition the jumper plug marked HEAT - A, B, C, (see Figure 59 and table on page 44 for "Allowable Heating Speeds". To determine what CFM the motor is delivering at any time, count the number of times the amber LED on the control board flashes. Each flash signifies 100 CFM; count the flashes and multiply by 100 to determine the actual CFM delivered (for example: 5 flashes x 100= 500).

#### Adjust Tap

Airflow amounts may be increased or decreased by 10% by moving the ADJUST jumper plug (see Figure 59) from the NORM position to the (+) or (-) position. Changes to the ADJUST tap will affect both cooling and heating airflows. The TEST position on the ADJUST tap is not used.

### Continuous Blower Operation

The comfort level of the living space can be enhanced when using this feature by allowing continuous circulation of air between calls for cooling or heating. The circulation of air occurs at the full cooling airflow rate.

To engage the continuous blower operation, place the fan switch on the thermostat into the ON position. A call for fan from the thermostat closes R to G on the ignition control board. The control waits for a 1 second thermostat delay before responding to the call for fan by ramping the circulating blower up to 38% of the cooling speed. When the call for continuous fan is satisfied, the control immediately ramps down the circulating blower.

## BLOWER DATA

### ML296UH045XV36B BLOWER PERFORMANCE (less filter)

BOTTOM RETURN AIR, SINGLE SIDE RETURN AIR OR SIDE RETURN AIR WITH OPTIONAL RETURN AIR BASE

0 through 0.8 in. w.g. (Heating) and 0 through 1.0 in. w.g. (Cooling) External Static Pressure Range

"ADJUST" Switch Positions	Speed Switch Positions							
	Second Stage "HEAT" Speed - cfm				Second Stage "COOL" Speed - cfm			
	D	C	<sup>1</sup> B	A	D	C	B	<sup>1</sup> A
+	765	860	960	1050	885	1095	1210	1370
<sup>1</sup> NORM	690	775	855	950	800	990	1115	1255
—	610	710	770	845	710	880	995	1115
"ADJUST" Switch Positions	First Stage "HEAT" Speed - cfm				First Stage "COOL" Speed - cfm			
	D	C	<sup>1</sup> B	A	D	C	B	<sup>1</sup> A
	+	700	790	855	925	615	780	900
<sup>1</sup> NORM	640	705	780	840	565	690	800	895
—	550	645	700	755	500	615	715	790

<sup>1</sup> Factory default jumper setting.

NOTES - The effect of static pressure is included in air volumes shown.

First stage HEAT is approximately **91%** of the same second stage HEAT speed position.

First stage COOL (two-stage air conditioning units only) is approximately **70%** of the same second stage COOL speed position.

Continuous Fan Only speed is approximately **38%** of the same second stage COOL speed position.

Lennox Harmony III™ Zoning System Applications - Minimum blower speed is 300 cfm.

## BLOWER DATA

### ML296UH070XV36B BLOWER PERFORMANCE (less filter)

BOTTOM RETURN AIR, SINGLE SIDE RETURN AIR OR SIDE RETURN AIR WITH OPTIONAL RETURN AIR BASE

0 through 0.8 in. w.g. (Heating) and 0 through 1.0 in. w.g. (Cooling) External Static Pressure Range

"ADJUST" Switch Positions	Speed Switch Positions							
	Second Stage "HEAT" Speed - cfm				Second Stage "COOL" Speed - cfm			
	D	C	<sup>1</sup> B	A	D	C	B	<sup>1</sup> A
+	955	1025	1085	1175	920	1095	1235	1330
<sup>1</sup> NORM	880	935	990	1070	840	990	1120	1200
—	790	840	890	965	750	885	1000	1075
"ADJUST" Switch Positions	First Stage "HEAT" Speed - cfm				First Stage "COOL" Speed - cfm			
	D	C	<sup>1</sup> B	A	D	C	B	<sup>1</sup> A
	+	865	925	980	1055	655	780	850
<sup>1</sup> NORM	795	845	900	975	580	700	765	850
—	715	770	805	865	515	630	690	760

<sup>1</sup> Factory default jumper setting.

NOTES - The effect of static pressure is included in air volumes shown.

First stage HEAT is approximately **90%** of the same second stage HEAT speed position.

First stage COOL (two-stage air conditioning units only) is approximately **70%** of the same second stage COOL speed position.

Continuous Fan Only speed is approximately **38%** of the same second stage COOL speed position.

Lennox HarmonyIII™ Zoning System Applications - Minimum blower speed is 300 cfm

## BLOWER DATA

### ML296UH090XV48C BLOWER PERFORMANCE (less filter)

#### BOTTOM RETURN AIR, SINGLE SIDE RETURN AIR OR SIDE RETURN AIR WITH OPTIONAL RETURN AIR BASE

0 through 0.8 in. w.g. (Heating) and 0 through 1.0 in. w.g. (Cooling) External Static Pressure Range

"ADJUST" Switch Positions	Speed Switch Positions							
	Second Stage "HEAT" Speed - cfm				Second Stage "COOL" Speed - cfm			
	D	C	<sup>1</sup> B	A	D	C	B	<sup>1</sup> A
+	1205	1290	1330	1555	1135	1355	1525	1765
<sup>1</sup> NORM	1075	1155	1200	1410	1080	1270	1435	1655
—	970	1040	1085	1250	940	1115	1255	1460
"ADJUST" Switch Positions	First Stage "HEAT" Speed - cfm				First Stage "COOL" Speed - cfm			
	D	C	<sup>1</sup> B	A	D	C	B	<sup>1</sup> A
	+	1125	1205	1245	1475	830	985	1095
<sup>1</sup> NORM	1040	1110	1135	1345	765	920	1040	1195
—	935	1000	1030	1210	675	795	900	1040

<sup>1</sup> Factory default jumper setting.

NOTES - The effect of static pressure is included in air volumes shown.

First stage HEAT is approximately **95%** of the same second stage HEAT speed position.

First stage COOL (two-stage air conditioning units only) is approximately **70%** of the same second stage COOL speed position.

Continuous Fan Only speed is approximately **38%** of the same second stage COOL speed position.

Lennox HarmonyIII™ Zoning System Applications - Minimum blower speed is 380 cfm.

## BLOWER DATA

### ML296UH110XV60C BLOWER PERFORMANCE (less filter)

#### BOTTOM RETURN AIR, SINGLE SIDE RETURN AIR OR SIDE RETURN AIR WITH OPTIONAL RETURN AIR BASE

**NOTE** - Air volumes in **bold** (over 1800 cfm) must have one of the following:

- Single side return air and Optional Return Air Base with transition that must accommodate required 20 x 25 x 1 inch air filter to maintain proper velocity
- Bottom return air
- Return air from both sides
- Bottom and one side return air

0 through 0.8 in. w.g. (Heating) and 0 through 1.0 in. w.g. (Cooling) External Static Pressure Range

"ADJUST" Switch Positions	Speed Switch Positions							
	Second Stage "HEAT" Speed - cfm				Second Stage "COOL" Speed - cfm			
	D	C	<sup>1</sup> B	A	D	C	B	<sup>1</sup> A
+	1680	<b>1805</b>	<b>1950</b>	<b>2105</b>	1405	1620	<b>1820</b>	<b>2055</b>
<sup>1</sup> NORM	1550	1665	<b>1800</b>	<b>1950</b>	1255	1455	1655	<b>1860</b>
—	1400	1505	1625	1750	1145	1335	1515	1700
"ADJUST" Switch Positions	First Stage "HEAT" Speed - cfm				First Stage "COOL" Speed - cfm			
	D	C	<sup>1</sup> B	A	D	C	B	<sup>1</sup> A
	+	1290	1390	1505	1615	1015	1165	1325
<sup>1</sup> NORM	1170	1270	1375	1475	905	1055	1200	1335
—	1070	1160	1250	1345	800	950	1080	1220

<sup>1</sup> Factory default jumper setting.

NOTES - The effect of static pressure is included in air volumes shown.

First stage HEAT is approximately **75%** of the same second stage HEAT speed position.

First stage COOL (two-stage air conditioning units only) is approximately **70%** of the same second stage COOL speed position.

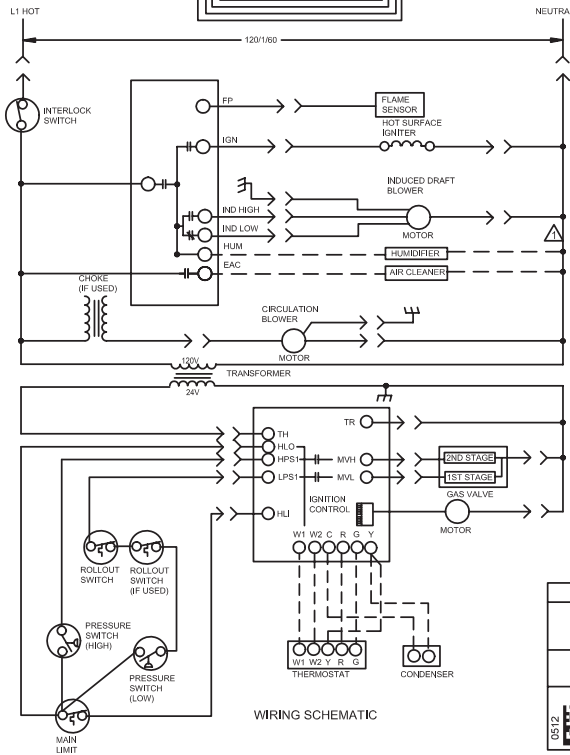
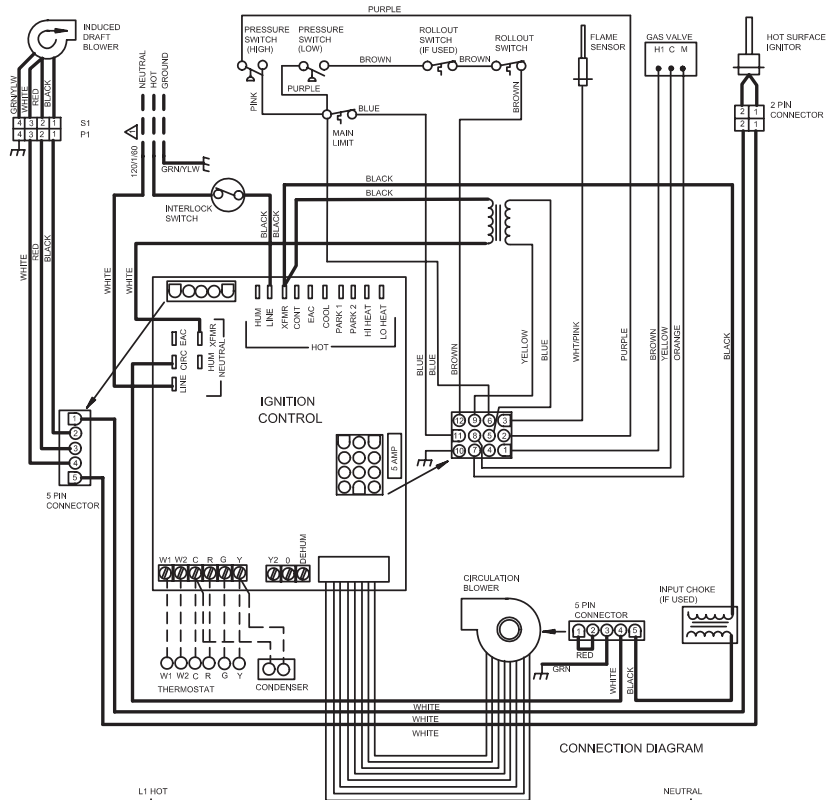
Continuous Fan Only speed is approximately **38%** of the same second stage COOL speed position.

Lennox HarmonyIII™ Zoning System Applications - Minimum blower speed is 460 cfm.

<b>Allowable Heating Speeds</b>												
ML296UHV Model	Speed Adjust	Setting "D"	Setting "C"	Setting "B"	Setting "A"							
045XV36B	+10%	Allowed	Allowed	Allowed	Allowed							
	Norm			Factory Setting								
	-10%			Allowed								
070XV36B	+10%			Allowed	Allowed	Allowed	Not Allowed					
	Norm					Factory Setting						
	-10%					Allowed						
090XV48C	+10%					Allowed		Allowed	Allowed	Not Allowed		
	Norm								Factory Setting			
	-10%								Allowed			
110XV60C	+10%						Allowed		Allowed		Allowed	Allowed
	Norm										Factory Setting	
	-10%										Allowed	

<b>Allowable Circulation Speeds</b>	
Model Number	38% Second stage Cool Speed
All Models	Factory Setting

# ML296UHV Schematic Wiring Diagram



PROPER POLARITY MUST BE OBSERVED FOR FIELD LINE VOLTAGE SUPPLY. IGNITION CONTROL WILL LOCK OUT IF POLARITY IS REVERSED

FOR TEMPORARY SERVICE REPLACEMENT ON CIRCULATING BLOWER MOTOR WITH PSC MOTOR, CONNECT MOTOR LEADS TO "EAC" TERMINALS ON IGNITION CONTROL

WARNING- ELECTRIC SHOCK HAZARD, CAN CAUSE INJURY OR DEATH. UNIT MUST BE GROUNDED IN ACCORDANCE WITH NATIONAL AND LOCAL CODES.

NOTE- IF ANY WIRE IN THIS APPLIANCE IS REPLACED, IT MUST BE REPLACED WITH WIRE OF LIKE SIZE, RATING, INSULATION THICKNESS, AND TERMINATION

- LINE VOLTAGE - FIELD INSTALLED
- LINE VOLTAGE - FACTORY
- - - CLASS II VOLTAGE - FIELD WIRING
- LOW VOLTAGE - FACTORY

HEATING UNITS-GAS	
GAS FIRED TWO STAGE FURNACE	
0512	Supersedes 537437-01
Form No. 537567-01	

FIGURE 61

## Integrated Control

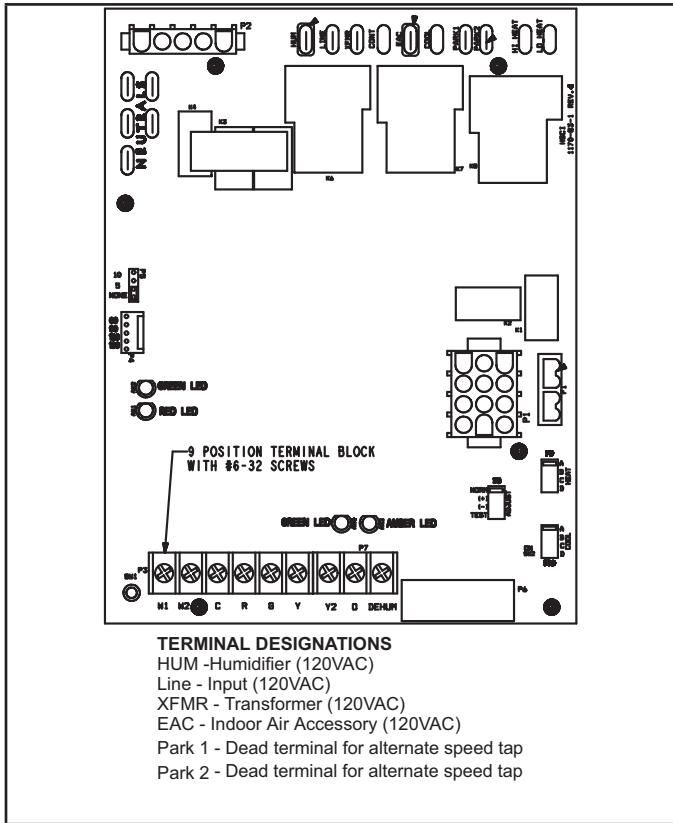


FIGURE 62

TABLE 11

Diagnostic Codes Red LED	
LED Off	No power to control or control hardware fault detected.
LED On	Normal operation.
1 Flash	Flame present with gas valve de-energized.
2 Flashes	Pressure switch closed with combustion air inducer de-energized.
3 Flashes	Low-fire pressure, rollout or limit switch open.
4 Flashes	Primary limit switch open.
5 Flashes	Not used
6 Flashes	Pressure switch cycle lockout.
7 Flashes	Lockout, burners fail to light.
8 Flashes	Lockout, burners lost flame too many times.
9 Flashes	Line voltage polarity incorrect.

## Troubleshooting

Make the following visual checks before troubleshooting:

- 1 - Check to see that the power to the furnace and the integrated ignition/blower control is ON.
- 2 - The manual shutoff valves in the gas line to the furnace must be open.
- 3 - Make sure all wiring connections are secure.
- 4 - Review the Sequence of Operation.

Start the system by setting thermostat above room temperature. Observe system response. Then use the information provided in this section to check the system operation.

The furnace has a built-in, self-diagnostic capability. If a system problem occurs, a fault code is shown by a red LED on the control. The control continuously monitors its own operation and the operation of the system. If a failure occurs, the LED will indicate the failure code. The flash codes are presented in TABLE 11.

### Fault Code History Button

The control stores the last five fault codes in memory. A pushbutton switch is located on the control. When the pushbutton switch is pressed and released, the control flashes the stored fault codes. The most recent fault code is flashed first; the oldest fault code is flashed last. To clear the fault code history, press and hold the pushbutton switch in for more than 5 seconds before releasing.

### High Heat State LED

A green LED is provided on the control board to indicate high heat state (see TABLE 12).

### CFM LED

An amber LED is provided on the control board to display CFM. To determine what CFM the motor is delivering at any time, count the number of times the amber LED flashes. Each flash signifies 100 CFM; count the flashes and multiply by 100 to determine the actual CFM delivered (for example: 5 flashes x 100 = 500 CFM).

TABLE 12

High Heat State Green LED	
LED Status	DESCRIPTION
LED Off	No demand for high heat
LED On	High heat demand, operating normally
LED Flashing	High heat demand, high pressure switch not closed

## Unit Start-Up

### FOR YOUR SAFETY READ BEFORE OPERATING

## ⚠ WARNING

Do not use this furnace if any part has been underwater. A flood-damaged furnace is extremely dangerous. Attempts to use the furnace can result in fire or explosion. Immediately call a qualified service technician to inspect the furnace and to replace all gas controls, control system parts, and electrical parts that have been wet or to replace the furnace, if deemed necessary.

## ⚠ WARNING



Danger of explosion. Can cause injury or product or property damage. If overheating occurs or if gas supply fails to shut off, shut off the manual gas valve to the appliance before shutting off electrical supply.

## ⚠ CAUTION

Before attempting to perform any service or maintenance, turn the electrical power to unit OFF at disconnect switch.

**BEFORE LIGHTING** the unit, smell all around the furnace area for gas. Be sure to smell next to the floor because some gas is heavier than air and will settle on the floor.

The gas valve on the ML296UHV is equipped with a gas control switch (lever). Use only your hand to move switch. Never use tools. If the switch will not move by hand, do not try to repair it. Force or attempted repair may result in a fire or explosion.

### Placing the furnace into operation:

ML296UHV units are equipped with an automatic hot surface ignition system. Do not attempt to manually light burners on this furnace. Each time the thermostat calls for heat, the burners will automatically light. The ignitor does not get hot when there is no call for heat on these units.

### Priming Condensate Trap

The condensate trap should be primed with water prior to start-up to ensure proper condensate drainage. Either pour 10 fl. oz. (300 ml) of water into the trap, or follow these steps to prime the trap:

- 1 - Follow the lighting instructions to place the unit into operation.
- 2 - Set the thermostat to initiate a heating demand.
- 3 - Allow the burners to fire for approximately 3 minutes.
- 4 - Adjust the thermostat to deactivate the heating demand.
- 5 - Wait for the combustion air inducer to stop. Set the thermostat to initiate a heating demand and again allow the burners to fire for approximately 3 minutes

- 6 - Adjust the thermostat to deactivate the heating demand and wait for the combustion air inducer to stop. At this point, the trap should be primed with sufficient water to ensure proper condensate drain operation.

## ⚠ WARNING

If you do not follow these instructions exactly, a fire or explosion may result causing property damage, personal injury or death.

### Gas Valve Operation (FIGURE 63)

- 1 - **STOP!** Read the safety information at the beginning of this section.
- 2 - Set the thermostat to the lowest setting.
- 3 - Turn off all electrical power to the unit.
- 4 - This furnace is equipped with an ignition device which automatically lights the burners. Do not try to light the burners by hand.
- 5 - Remove the access panel.
- 6 - Move gas valve switch to **OFF**. See FIGURE 63.
- 7 - Wait five minutes to clear out any gas. If you then smell gas, **STOP!** Immediately call your gas supplier from a neighbor's phone. Follow the gas supplier's instructions. If you do not smell gas go to next step.
- 8 - Move gas valve switch to **ON**. See FIGURE 63.

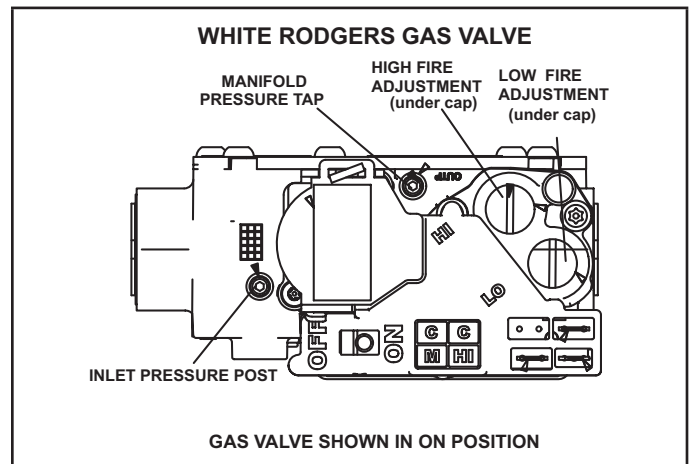


FIGURE 63

- 9 - Replace the access panel.
- 10 - Turn on all electrical power to the unit.
- 11 - Set the thermostat to desired setting.  
**NOTE** - When unit is initially started, steps 1 through 11 may need to be repeated to purge air from gas line.
- 12 - If the appliance will not operate, follow the instructions "Turning Off Gas to Unit" and call your service technician or gas supplier.

### Turning Off Gas to Unit

- 1 - Set the thermostat to the lowest setting.
- 2 - Turn off all electrical power to the unit if service is to be performed.
- 3 - Remove the access panel.

- 4 - Move gas valve switch to **OFF**.
- 5 - Replace the access panel.

**Failure To Operate**

If the unit fails to operate, check the following:

- 1 - Is the thermostat calling for heat?
- 2 - Are access panels securely in place?
- 3 - Is the main disconnect switch closed?
- 4 - Is there a blown fuse or tripped breaker?
- 5 - Is the filter dirty or plugged? Dirty or plugged filters will cause the limit control to shut the unit off.
- 6 - Is gas turned on at the meter?
- 7 - Is the manual main shut-off valve open?
- 8 - Is the internal manual shut-off valve open?
- 9 - Is the unit ignition system in lockout? If the unit locks out again, inspect the unit for blockages.

**Heating Sequence Of Operation**

- 1 - When thermostat calls for heat, combustion air inducer starts.
- 2 - Combustion air pressure switch proves blower operation. Switch is factory set and requires no adjustment.
- 3 - After a 15-second prepurge, the hot surface ignitor energizes.
- 4 - After a 20-second ignitor warm-up period, the gas valve solenoid opens. A 4-second trial for ignition period begins.”
- 5 - Gas is ignited, flame sensor proves the flame, and the combustion process continues.
- 6 - If flame is not detected after first ignition trial, the ignition control will repeat steps 3 and 4 four more times before locking out the gas valve (“WATCHGUARD” flame failure mode). The ignition control will then automatically repeat steps 1 through 6 after 60 minutes. To interrupt the 60-minute “WATCHGUARD” period, move thermostat from “Heat” to “OFF” then back to “Heat”. Heating sequence then restarts at step 1.

**Gas Pressure Adjustment**

**Gas Flow (Approximate)**

**TABLE 13**

GAS METER CLOCKING CHART				
ML296 Unit	Seconds for One Revolution			
	Natural		LP	
	1 cu ft Dial	2 cu ft Dial	1 cu ft Dial	2 cu ft Dial
-045	80	160	200	400
-070	55	110	136	272
-090	41	82	102	204
-110	33	66	82	164
Natural-1000 btu/cu ft LP-2500 btu/cu ft				

Furnace should operate at least 5 minutes before checking gas flow. Determine time in seconds for two revolutions of gas through the meter. (Two revolutions assures a more accurate time.) Divide by two and compare to time in TABLE 13. If manifold pressure matches TABLE 15 and rate is incorrect, check gas orifices for proper size and restriction. Remove temporary gas meter if installed.

**NOTE** - To obtain accurate reading, shut off all other gas appliances connected to meter.

**Supply Pressure Measurement**

An inlet post located on the gas valve provides access to the supply pressure. See FIGURE 63. Back out the 3/32 hex screw one turn, connect a piece of 5/16 tubing and connect to a manometer to measure supply pressure. See TABLE 15 for supply line pressure.

On multiple unit installations, each unit should be checked separately, with and without units operating. Supply pressure must fall within range listed in TABLE 15.

**Manifold Pressure Measurement**

**NOTE** - Pressure test adapter kit (10L34) is available from Lennox to facilitate manifold pressure measurement.

A manifold pressure post located on the gas valve provides access to the manifold pressure. See FIGURE 63. Back out the 3/32 hex screw one turn, connect a piece of 5/16 tubing and connect to a manometer to measure manifold pressure.

To correctly measure manifold pressure, the differential pressure between the positive gas manifold and the negative burner box must be considered.

- 1 - Connect the test gauge positive side “+” to manifold pressure tap on gas valve as noted above.
- 2 - Tee into the gas valve regulator vent hose and connect to test gauge negative “-”.
- 3 - Ignite unit on low fire and let run for 5 minutes to allow for steady state conditions.
- 4 - After allowing unit to stabilize for 5 minutes, record manifold pressure and compare to value given in TABLE 15.
- 5 - If necessary, make adjustments. FIGURE 63 shows location of high fire and low fire adjustment screws.
- 6 - Repeat steps 3, 4 and 5 on high fire. See values in TABLE 15.
- 7 - Shut unit off and remove manometer as soon as an accurate reading has been obtained. Turn the supply and manifold 3/32” hex screws one revolution back into the gas valve.
- 8 - Start unit and perform leak check. Seal leaks if found.



### Proper Combustion

Furnace should operate minimum 15 minutes with correct manifold pressure and gas flow rate before checking combustion. Take combustion sample beyond the flue outlet and compare to the tables below.

**TABLE 14**

ML296 Model	CO <sub>2</sub> % For Nat		CO <sub>2</sub> % For L.P	
	Low Fire	High Fire	Low Fire	High Fire
045	5.4 - 6.4	7.5 - 8.5	6.4 - 7.4	8.8 - 9.8
070	5.3 - 6.3	7.4 - 8.4	6.3 - 7.3	8.7 - 9.7
090	5.8 - 6.8	7.6 - 8.6	6.8 - 7.8	8.9 - 9.9
110	6.1 - 7.1	8.0 - 9.0	7.1 - 8.1	9.3 - 10.3

The maximum carbon monoxide reading should not exceed 100ppm.

### High Altitude Information

NOTE - In Canada, certification for installations at elevations over 4500 feet (1372 m) is the jurisdiction of local authorities.

Units may be installed at altitudes up to 10,000 ft. above sea level. See TABLE 15 for de-rate manifold values. Units installed at altitude of 7501 - 10,000 feet require an orifice change. Units installed at altitude of 4501 - 10,000 feet require a pressure switch change which can be ordered separately. TABLE 16 lists conversion kit and pressure switch requirements at varying altitudes.

The combustion air pressure switch is factory-set and requires no adjustment.

**TABLE 15**

Manifold and Supply Line Pressure 0-10,000ft.

Unit	Gas	Manifold Pressure in. wg.										Supply Line Pressure in. w.g 0 - 10,000 ft.	
		0 - 4500 ft		4501 - 5500 ft.		5501 - 6500 ft		6501 - 7500 ft		7501 - 10,000 ft		Min	Max
		Low Fire	High Fire	Low Fire	High Fire	Low Fire	High Fire	Low Fire	High Fire	Low Fire	High Fire		
All Sizes	Natural	1.7	3.5	1.6	3.3	1.5	3.2	1.5	3.1	1.7	3.5	4.5	13.0
	LP/ Propane	4.5	10.0	4.2	9.4	4.0	9.1	3.9	8.9	4.5	10.0	11.0	13.0

NOTE - A natural to L.P. propane gas changeover kit is necessary to convert this unit. Refer to the changeover kit installation instruction for the conversion procedure.

**TABLE 16**

LP/Propane Conversion Kit and Pressure Switch Requirements at Varying Altitudes

Unit	Natural to LP/Propane	High Altitude Natural Burner Orifice Kit	High Altitude LP/Propane Burner Orifice Kit	High Altitude Pressure Switch	
	0 - 7500 ft	7501 - 10,000 ft	7501 - 10,000 ft	4501 - 7500 ft	7501 - 10,000 ft
045	*11K51	73W37	*11K46	14A47	14A50
070				14A54	14A53
090				14A57	14A54
110				14A46	14A51
135				14A49	14A51

\* Conversion requires installation of a gas valve manifold spring which is provided with the gas conversion kit. Pressure switch is factory set. No adjustment necessary. All models use the factory-installed pressure switch from 0-4500 feet (0-1370 m).

**⚠ WARNING**

**CARBON MONOXIDE POISONING HAZARD!**

Failure to follow the steps outlined below for each appliance connected to the venting system being placed into operation could result in carbon monoxide poisoning or death.

The following steps shall be followed for each appliance connected to the venting system being placed into operation, while all other appliances connected to the venting system are not in operation.

After the ML296UHV gas furnace has been started, the following test should be conducted to ensure proper venting and sufficient combustion air has been provided to the ML296UHV as well as to other gas-fired appliances which are separately vented.

If a ML296UHV furnace replaces a Category I furnace which was commonly vented with another gas appliance, the size of the existing vent pipe for that gas appliance must be checked. Without the heat of the original furnace flue products, the existing vent pipe is probably oversized for the single water heater or other appliance. The vent should be checked for proper draw with the remaining appliance.

The test should be conducted while all appliances (both in operation and those not in operation) are connected to the venting system being tested. If the venting system has been installed improperly, or if provisions have not been made for sufficient amounts of combustion air, corrections must be made as outlined in the previous section.

- 1 - Seal any unused openings in the venting system.
- 2 - Visually inspect the venting system for proper size and horizontal pitch. Determine there is no blockage or restriction, leakage, corrosion, or other deficiencies which could cause an unsafe condition.

- 3 - To the extent that it is practical, close all building doors and windows and all doors between the space in which the appliances connected to the venting system are located and other spaces of the building.
- 4 - Close fireplace dampers.
- 5 - Turn on clothes dryers and any appliances not connected to the venting system. Turn on any exhaust fans, such as range hoods and bathroom exhausts, so they will operate at maximum speed. Do not operate a summer exhaust fan.
- 6 - Follow the lighting instruction to place the appliance being inspected into operation. Adjust thermostat so appliance will operate continuously.
- 7 - Use the flame of match or candle to test for spillage of flue gases at the draft hood relief opening after 5 minutes of main burner operation.
- 8 - If improper venting is observed during any of the above tests, the venting system must be corrected or sufficient combustion/make-up air must be provided. The venting system should be re-sized to approach the minimum size as determined by using the appropriate tables in appendix G in the current standards of the National Fuel Gas Code ANSI-Z223.1/NPFA 54 in the U.S.A., and the appropriate Natural Gas and Propane appliances venting sizing tables in the current standard of the CSA-B149 Natural Gas and Propane Installation Codes in Canada.
- 9 - After determining that each appliance remaining connected to the common venting system properly vents when tested as indicated in step 3, return doors, windows, exhaust fans, fireplace dampers and any other gas-burning appliance to their previous condition of use.

## Repair Parts List

The following repair parts are available through Lennox dealers. When ordering parts, include the complete furnace model number listed on the CSA nameplate -- Example: ML296UH045XV36B. **All service must be performed by a licensed professional installer (or equivalent), service agency, or gas supplier.**

### Cabinet Parts

- Outer access panel
- Blower access panel
- Top Cap

### Control Panel Parts

- Transformer
- Integrated control board
- Door interlock switch

### Blower Parts

- Blower wheel
- Motor
- Motor mounting frame
- Motor capacitor
- Blower housing cutoff plate

### Heating Parts

- Flame Sensor
- Heat exchanger assembly
- Gas manifold
- Combustion air inducer
- Gas valve
- Main burner cluster
- Main burner orifices
- Pressure switch
- Ignitor
- Primary limit control
- Flame rollout switches

## Other Unit Adjustments

### Primary Limit.

The primary limit is located on the heating compartment vestibule panel. This limit is factory set and requires no adjustment.

### Flame Rollout Switches (Two)

These manually reset switches are located on the front of the burner box.

### Pressure Switch

The pressure switch is located in the heating compartment on the cold end header box. This switch checks for proper combustion air inducer operation before allowing ignition trial. The switch is factory-set and must not be adjusted.

### Temperature Rise

Place the unit into operation with a second-stage heating demand. After supply and return air temperatures have stabilized, check the temperature rise. If necessary, adjust the heating blower speed to maintain the temperature rise within the range shown on the unit nameplate. See "Allowable Heating Speeds" table on page 44. Increase the blower speed to decrease the temperature rise. Decrease the blower speed to increase the temperature rise. Failure to properly adjust the temperature rise may cause erratic limit operation.

### Electrical

- 1 - Check all wiring for loose connections.
- 2 - Check for the correct voltage at the furnace (furnace operating). Correct voltage is 120VAC + 10%
- 3 - Check amp-draw on the blower motor with blower access panel in place.

Unit Nameplate \_\_\_\_\_ Actual \_\_\_\_\_

### Exhaust and Air Intake Pipe

- 1 - Check exhaust and air intake connections for tightness and to make sure there is no blockage.
- 2 - Is pressure switch closed? Obstructed exhaust pipe will cause unit to shut off at pressure switch. Check termination for blockages.
- 3 - Obstructed pipe or termination may cause rollout switches to open. Reset manual flame rollout switches on burner box assembly if necessary.

## Heating Sequence of Operation

On a call for heat from the room thermostat, the control board performs a 1 second self check. Upon confirmation that the pressure switch contacts are in an open position, the control energizes the combustion blower on high speed. The control then checks for adequate combustion air by making sure the low-fire pressure switch contacts are closed.

The igniter energizes and is allowed to warm up for 20 seconds before the gas valve energizes on 1st stage and burners ignite. 45 seconds after the control confirms ignition has occurred, the control drops the combustion blower to low speed.

The circulating blower operates at full 1st stage heat speed until either the heat call is satisfied or the thermostat initiates a call for 2nd stage heat. On a call for 2nd stage heat, the control energizes the circulating air blower on full CFM 2nd stage heat.

If the automatic heat staging option is being used the furnace does not switch to 2nd stage heat in response to a call from the thermostat but instead operates at 1st stage heat for the duration of the selected time before automatically switching to 2nd stage heat.

When the call for heat is satisfied, the gas valve and combustion air blower shut down. The control board shuts off the gas valve and runs the combustion blower for an additional 15 seconds. The circulating air blower continues to run for selected blower off delay time (60/90/120/180 sec) before ramping down and shutting off.

In the event the unit loses ignition, the control will attempt to recycle up to five times before it goes into a 1 hour lockout. Lockout may be manually reset by removing power from the control for more than 1 second or removing the thermostat call for heat for more than 3 seconds.

If during a heating cycle the limit control senses an abnormally high temperature and opens, the control board de-energizes the gas valve and the combustion blower while the circulating blower ramps up to 1st stage heat speed. The circulating blower remains energized until the limits are closed.

### Fan On

When the thermostat is set for continuous fan operation and there is no demand for heating or cooling, a call for fan closes the R to G circuit and the circulating blower motor runs at 38% of the selected cooling CFM until switched off. When the call for fan is turned off, the control de-energizes the circulating blower.

### Cooling

The unit is set up at the factory for single stage cooling. For two stage cooling operation, clip the jumper wire located between the Y to Y2 terminals on the integrated ignition/ blower control board. If the active dehumidification feature is enabled, the circulating blower runs at 70% of the selected cooling speed as long as there is a call for dehumidification.

## WARNING

The system must not be in either the passive or active dehumidification mode when charging a cooling system.

## Single Stage Cooling

A call for cooling from the thermostat closes the R to Y circuit on the integrated ignition/blower control board. The control waits for a 1-second delay before energizing the circulating blower to 82% of the selected cooling CFM (passive dehumidification mode). After 7.5 minutes, the circulating blower automatically ramps up to 100% of the selected cooling airflow. When the call for cooling is satisfied, the circulating blower continuous running at same cfm for another 45 seconds, then shuts down.

## Two-Stage Cooling

A call for 1st stage cooling from the thermostat closes the R to Y circuit on the control board. The control waits for a 1- second delay before energizing the circulating blower. The blower motor runs at 57% of the selected air flow for the first 7.5 minutes of the 2nd stage cooling demand (passive dehumidification mode). After 7.5 minutes, the blower motor runs at 70% of the selected cooling air flow until 1st stage cooling demand is satisfied. A call for 2nd stage cooling from the thermostat closes the R to Y2 circuit on the control board. The blower motor ramps up to 100% of the selected cooling air flow. When the demand for cooling is met, the blower ramps down to Y1 until satisfied, then ramps down to 57% for 1 minute, then turns off.

## Heat Pump

For heat pump operation, clip the jumper wire located below the O terminal on the integrated ignition/blower control board. In heat pump mode, a call for heat will result in the circulating air blower operating at the selected cooling airflow with no ramp-up period.

### Service

## WARNING

ELECTRICAL SHOCK, FIRE,  
OR EXPLOSION HAZARD.

Failure to follow safety warnings exactly could result in dangerous operation, serious injury, death or property damage.

Improper servicing could result in dangerous operation, serious injury, death, or property damage. Before servicing, disconnect all electrical power to furnace.

When servicing controls, label all wires prior to disconnecting. Take care to reconnect wires correctly. Verify proper operation after servicing.

## WARNING

The blower access panel must be securely in place when the blower and burners are operating. Gas fumes, which could contain carbon monoxide, can be drawn into living space resulting in personal injury or death.

## Annual Furnace Maintenance

At the beginning of each heating season, and to comply with the **Lennox Limited Warranty**, your system should be checked as follows:

- 1- Check wiring for loose connections, voltage at indoor unit and amperage of indoor motor.
- 2- Check the condition of the belt and shaft bearings if applicable.
- 3- Inspect all gas pipe and connections for leaks.
- 4- Check the cleanliness of filters and change if necessary (monthly).
- 5- Check the condition and cleanliness of burners and heat exchanger and clean if necessary.
- 6- Check the cleanliness of blower assembly and clean the housing, blower wheel and blower motor if necessary.
- 7- Inspect the condensate drain and trap for leaks and cracks. The drain and trap must also be cleaned and the trap must be primed with water. Inspect the rubber hoses connected to the pressure switches for cracks or loose connections, replace as necessary. Remove the rubber hoses from the cold end header box and inspect for any blockage, clean as needed. If strainers are installed in the hoses remember to remove and clean before reinstalling the hoses.
- 8- Evaluate the heat exchanger integrity by inspecting the heat exchanger per the AHRI heat exchanger inspection procedure. This procedure can be viewed at [www.ahrinet.org](http://www.ahrinet.org)
- 9- Ensure sufficient combustion air is available to the furnace. Fresh air grilles and louvers (on the unit and in the room where the furnace is installed) must be properly sized, open and unobstructed to provide combustion air.
- 10- Inspect the furnace intake and exhaust pipes to make sure they are in place, structurally sound, without holes, blockage or leakage and the exhaust pipe is sloped toward the furnace. Inspect terminations to ensure they are free of obstructions and are structurally sound. Inspect the furnace return air duct connection to ensure the duct is sealed to the furnace. Check for air leaks on supply and return ducts and seal where necessary.
- 11- Inspect the furnace return air duct connection to ensure the duct is sealed to the furnace. Check for air leaks on supply and return ducts and seal where necessary.

- 12- Check the condition of the furnace cabinet insulation and repair if necessary.
- 13- Perform a complete combustion analysis during the furnace inspection to ensure proper combustion and operation. Consult Service Literature for proper combustion values.
- 14- Verify operation of CO detectors and replace batteries as required.

Perform a general system test. Turn on the furnace to check operating functions such as the start-up and shut-off operation.

- 1 - Check the operation of the ignition system, inspect and clean flame sensor. Check microamps before and after. Check controls and safety devices (gas valve, flame sensor, temperature limits). Consult Service Manual for proper operating range. Thermal Limits should be checked by restricting airflow and not disconnecting the indoor blower. For additional details, please see Service and Application Note H049.
- 2 - Verify that system total static pressure and airflow settings are within specific operating parameters.
- 3 - Clock gas meter to ensure that the unit is operating at the specified firing rate for each stage of operation. Check the supply pressure and the manifold pressure on both low fire and high fire. If manifold pressure adjustment is necessary, consult the Service Literature for unit specific information on adjusting gas pressure. Not all gas valves are adjustable. Verify correct temperature rise.

#### **Winterizing and Condensate Trap Care**

- 1 - Turn off power to the furnace.
- 2 - Have a shallow pan ready to empty condensate water.
- 3 - Remove the clean out cap from the condensate trap and empty water. Inspect the trap then reinstall the clean out cap.

#### **Cleaning The Burner Assembly**

If cleaning the burner assembly becomes necessary, follow the steps below:

- 1 - Turn off electrical and gas power supplies to furnace. Remove upper and lower furnace access panels.
- 2 - Disconnect the wires from the gas valve.
- 3 - Remove the burner box cover (if equipped).
- 4 - Disconnect the gas supply line from the gas valve. Remove gas valve/manifold assembly.
- 5 - Mark and disconnect sensor wire from the sensor. Disconnect wires from flame rollout switches.
- 6 - Disconnect combustion air intake pipe. It may be necessary to cut the existing pipe to remove burner box assembly.
- 7 - Remove four screws which secure burner box assembly to vest panel. Remove burner box from the unit.
- 8 - Use the soft brush attachment on a vacuum cleaner to gently clean the face of the burners. Visually inspect the inside of the burners and crossovers for any blockage caused by foreign matter. Remove any blockage.
- 9 - Reinstall the burner box assembly using the existing four screws. Make sure that the burners line up in the center of the burner ports.
- 10 - Reconnect the sensor wire and reconnect the 2-pin plug to the ignitor wiring harness. Reconnect wires to flame rollout switches.
- 11 -Reinstall the gas valve manifold assembly. Reconnect the gas supply line to the gas valve. Reinstall the burner box cover.
- 12 - Reconnect wires to gas valve.
- 13 - Replace the blower compartment access panel.
- 14 - Refer to instruction on verifying gas and electrical connections when re-establishing supplies.
- 15 - Follow lighting instructions to light and operate furnace for 5 minutes to ensure that heat exchanger is clean and dry and that furnace is operating properly.
- 16 - Replace heating compartment access panel.

**Modifications to NFPA-54, Chapter 10**

**Revise NFPA-54 section 10.8.3 to add the following requirements:**

For all side wall, horizontally vented, gas-fueled equipment installed in every dwelling, building or structure used in whole or in part for residential purposes, including those owned or operated by the Commonwealth and where the side wall exhaust vent termination is less than seven (7) feet above the finished grade in the area of the venting, including but not limited to decks and porches, the following requirements shall be satisfied:

1 - **INSTALLATION OF CARBON MONOXIDE DETECTORS.** At the time of installation of the side wall, horizontally vented, gas-fueled equipment, the installing plumber or gasfitter shall observe that a hard-wired carbon monoxide detector with an alarm and battery backup is installed on the floor level where the gas equipment is to be installed. In addition, the installing plumber or gasfitter shall observe that a battery-operated or hard-wired carbon monoxide detector with an alarm is installed on each additional level of the dwelling, building or structure served by the side wall, horizontally vented, gas-fueled equipment. It shall be the responsibility of the property owner to secure the services of qualified licensed professionals for the installation of hard-wired carbon monoxide detectors.

- a. In the event that the side wall, horizontally vented, gas-fueled equipment is installed in a crawl space or an attic, the hard-wired carbon monoxide detector with alarm and battery back-up may be installed on the next adjacent floor level.
- b. In the event that the requirements of this subdivision cannot be met at the time of completion of installation, the owner shall have a period of thirty (30) days to comply with the above requirements; provided, however, that during said thirty (30) day period, a battery-operated carbon monoxide detector with an alarm shall be installed.

2 - **APPROVED CARBON MONOXIDE DETECTORS** carbon monoxide detector as required in accordance with the above provisions shall comply with NFPA 720 and be ANSI/UL 2034 listed and IAS certified.

3 - **SIGNAGE.** A metal or plastic identification plate shall be permanently mounted to the exterior of the building at a minimum height of eight (8) feet above grade directly in line with the exhaust vent terminal for the horizontally vented, gas-fueled heating appliance or equipment. The sign shall read, in print size no less than one-half (1/2) inch in size, "GAS VENT DIRECTLY BELOW. KEEP CLEAR OF ALL OBSTRUCTIONS

4 - **INSPECTION.** The state or local gas inspector of the side wall, horizontally vented, gas-fueled equipment shall not approve the installation unless, upon inspection, the inspector observes carbon monoxide detectors and signage installed in accordance with the provisions of 248 CMR 5.08(2)(a) 1 through 4.

**EXEMPTIONS: The following equipment is exempt from 24 CMR 5.08(2)(a) 1 through 4:**

- 1 - The equipment listed in Chapter 10 entitled "Equipment Not Required to Be Vented" in the most current edition of NFPA 54 as adopted by the Board; and
- 2 - Product Approved side wall, horizontally vented, gas fueled equipment installed in a room or structure separate from the dwelling, building or structure used in whole or in part for residential purposes.

**MANUFACTURER REQUIREMENTS - GAS EQUIPMENT VENTING SYSTEM PROVIDED.**

When the manufacturer of Product Approved side wall, horizontally vented, gas-fueled equipment provides a venting system design or venting system components with the equipment, the instructions provided by the manufacturer for installation of the equipment and the venting system shall include:

- 1 - Detailed instructions for the installation of the venting system design or the venting system components: and
- 2 - A complete parts list for the venting system design or venting system.

**MANUFACTURER REQUIREMENTS - GAS EQUIPMENT VENTING SYSTEM NOT PROVIDED.**

When the manufacturer of Product Approved side wall, horizontally vented, gas-fueled equipment does not provide the parts for venting the flue gases, but identifies "special venting systems," the following requirements shall be satisfied by the manufacturer:

- 1 - The referenced "special venting system" instructions shall be included with the appliance or equipment installation instructions; and
- 2 - The "special venting systems" shall be Product Approved by the Board, and the instructions for that system shall include a parts list and detailed installation instructions.

**A copy of all installation instructions for all Product Approved side wall, horizontally vented, gas-fueled equipment, all venting instructions, all parts lists for venting instructions, and/or all venting design instructions shall remain with the appliance or equipment at the completion of the installation.**

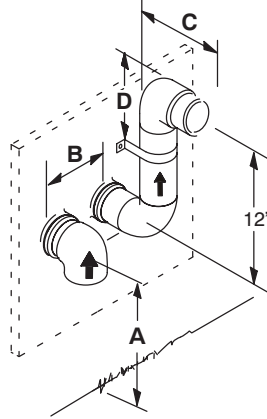
**FOR THE PROVINCE OF ONTARIO, HORIZONTAL SIDEWALL VENT APPLICATIONS ONLY**

For exterior horizontal venting applications, the 2" X 1.5" reducer for 2" venting at the point where the exhaust pipe exits the structure is not required in direct or nondirect vent applications in the Province of Ontario. In these applications, the vent should be oriented such that the exhaust plume is unobjectionable. If the installation requires more separation between the flue gases and the building structure, a reducer may be installed on the exhaust pipe to increase the flue gas velocity.

**ADDENDUM FOR ALL PROVINCES OF CANADA**

See below for venting in all provinces of Canada.

Lennox approves the following termination for use in all provinces of Canada.



	<b>2" (51MM) Vent Pipe</b>	<b>3" (76MM) Vent Pipe</b>
<b>A</b> – Clearance above grade or average snow accumulation	12" (305 mm) Min.	12" (305 mm) Min.
<b>B</b> – Horizontal separation between intake and exhaust	6" (152 mm) Min. 24" (610 mm) Max.	6" (152 mm) Min. 24" (610 mm) Max.
<b>C</b> – Exhaust pipe length	Per: Saskatchewan Code of Practice	
<b>D</b> – Wall support distance from top of each pipe (intake/exhaust)	6" (152 mm) Max.	6" (152 mm) Max.

**NOTE** – Flue gas may be acidic and may adversely affect some building materials. If flue gases impinge on the building materials, a corrosion-resistant shield should be used to protect the wall surface. The shield should be constructed using wood, sheet metal or other suitable material. All seams, joints, cracks, etc. in affected area, should be sealed using an appropriate sealant.

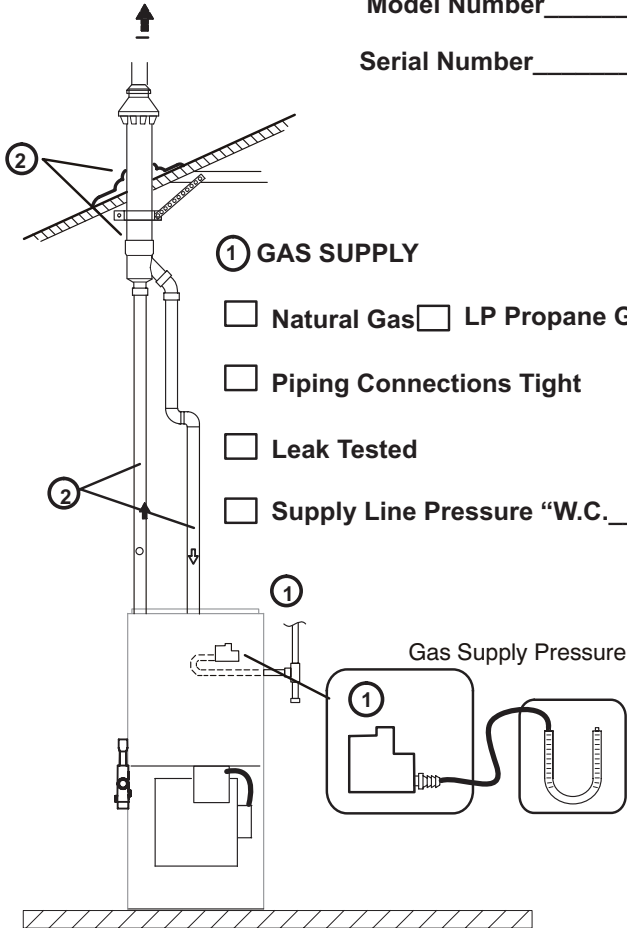




**UNIT SET UP  
(typical)**

Furnace:  
Model Number \_\_\_\_\_

Serial Number \_\_\_\_\_



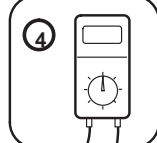
**① GAS SUPPLY**

- Natural Gas  LP Propane Gas
- Piping Connections Tight
- Leak Tested
- Supply Line Pressure "W.C. \_\_\_\_\_

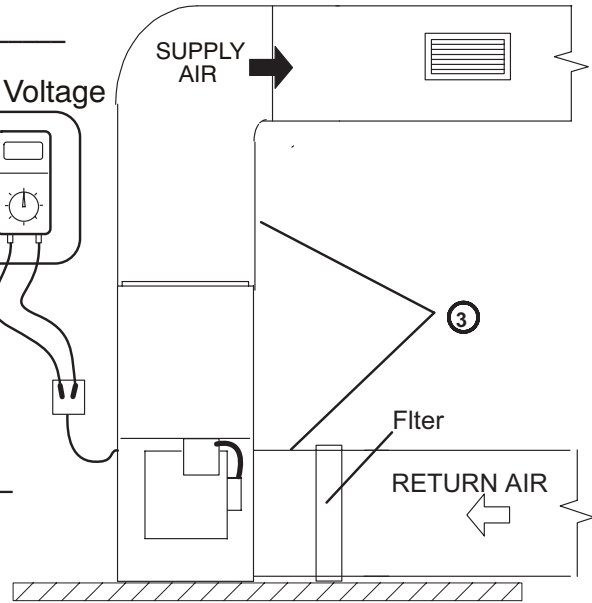
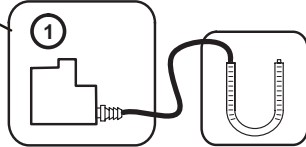
**② INTAKE / EXHAUST PIPE**

- All Joints Primed and Glued
- Terminations Installed Properly
- Horizontal Pipes Sloped (if applicable)
- Condensate Trap Primed / Line Sloped
- Pipes Supported
- Heat Cable Installed and Operable (if applicable)

**Line Voltage**



**Gas Supply Pressure**



**③ DUCT SYSTEM**

**SUPPLY AIR DUCT**

- Sealed
- Insulated (if necessary)

**RETURN DUCT**

- Sealed
- Filter Installed and Clean
- Grilles Unobstructed

**④ VOLTAGE CHECK**

- Supply Voltage \_\_\_\_\_
- Electrical Connections Tight



# UNIT OPERATION

## HEATING MODE

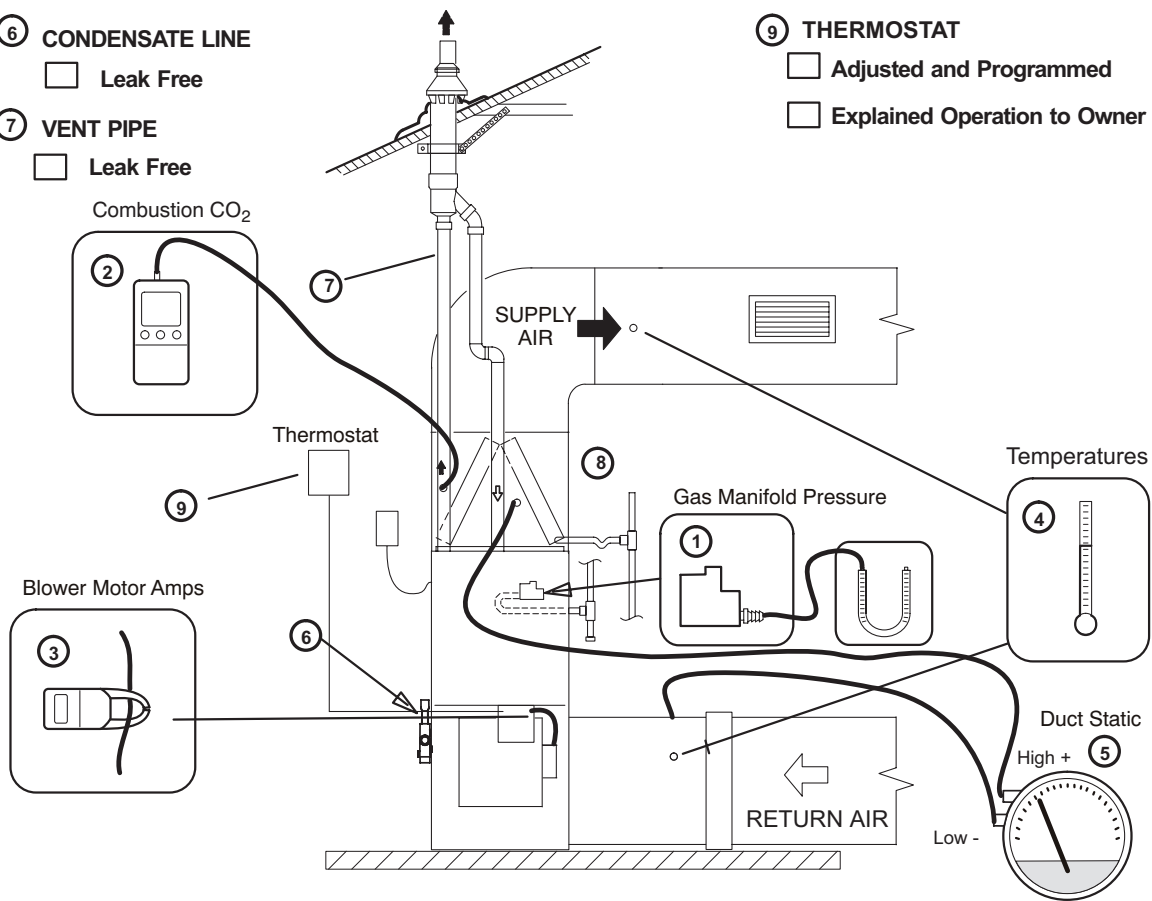
## COOLING MODE

- ① GAS MANIFOLD PRESSURE "W.C. \_\_\_\_\_
- ② COMBUSTION SAMPLE CO<sub>2</sub>% \_\_\_\_\_ CO PPM \_\_\_\_\_
- ③ INDOOR BLOWER AMPS \_\_\_\_\_
- ④ TEMPERATURE RISE  
Supply Duct Temperature \_\_\_\_\_  
Return Duct Temperature - \_\_\_\_\_  
Temperature Rise = \_\_\_\_\_
- ⑤ TOTAL EXTERNAL STATIC  
Supply External Static \_\_\_\_\_  
Return External Static + \_\_\_\_\_  
Total External Static = \_\_\_\_\_

- ③ INDOOR BLOWER AMPS \_\_\_\_\_
- ④ TEMPERATURE DROP  
Return Duct Temperature \_\_\_\_\_  
Supply Duct Temperature - \_\_\_\_\_  
Temperature Drop = \_\_\_\_\_
- ⑤ TOTAL EXTERNAL STATIC (dry coil)  
Supply External Static \_\_\_\_\_  
Return External Static + \_\_\_\_\_  
Total External Static = \_\_\_\_\_

- ⑥ CONDENSATE LINE  
 Leak Free
- ⑦ VENT PIPE  
 Leak Free

- ⑧ DRAIN LINE  
 Leak Free
- ⑨ THERMOSTAT  
 Adjusted and Programmed  
 Explained Operation to Owner



Contractor's Name \_\_\_\_\_ Telephone \_\_\_\_\_ Checklist Completed \_\_\_\_\_

Job Address \_\_\_\_\_ - \_\_\_\_\_ Technician's Name \_\_\_\_\_